



MINUTES

JUNE 23, 2026

BRAZOS COUNTY COMMISSIONERS COURT

REGULAR MEETING

A regular meeting of the Commissioners' Court of Brazos County, Texas was held in the Brazos County Commissioners Courtroom in the Administration Building, 200 South Texas Avenue, in Bryan, Brazos County, Texas, beginning at 10:15 a.m. on Tuesday, June 23, 2026 with the following members of the Court present:

Duane Peters, County Judge, Presiding;
Bentley Nettles, Commissioner of Precinct 1;
Chuck Konderla, Commissioner of Precinct 2;
Fred Brown, Commissioner of Precinct 3;
Wanda J. Watson, Commissioner of Precinct 4;
Karen McQueen, County Clerk;

The attached sheets contain the names of the citizens and officials that were in attendance.

1. Invocation and Pledge of Allegiance
 - U.S. and Texas Flag - Commissioner Nettles

2. Call for Citizen input and/or concerns

Gina Mosavi, DVM, resident of Precinct 1, addressed the Court concerning the New World Screwworm.

Cathie Viens, resident of Precinct 4, addressed the Court concerning financial decisions on Capital Projects. Ms. Viens provided a copy of her statement for the record it is attached hereto.

Peter Michelena, resident of Precinct 4, addressed the Court concerning the Master Plan. Mr. Michelena provided a handout to the Court it is attached hereto.

Ivan Svrcek, resident of Precinct 2, addressed the Court in opposition to the ALPR cameras. Mr. Svrcek provided a handout to the Court it is attached hereto.

Cynde Wiley, resident of Precinct 1, addressed the Court concerning elections.

3. Presentations and/or Discussions

- Presentation and discussion regarding recognition of the Brazos County Historical Commission as a recipient of the 2025 Distinguished Service Award from the Texas Historical Commission.

Judge Peters congratulated the Brazos County Historical Commission on being awarded the 2025 Distinguished Service Award. Chairman Henry Mayo of the Brazos County Historical Commission thanked the Court for its continued support of the Historical Commission and its initiatives. He stated that the Commission strives to remain active and serve as a responsible steward of the funds provided by Brazos County.

Mr. Mayo reported that the Commission is currently working to install additional historical markers throughout the county. He further advised that a significant portion of the Commission's current efforts is focused on researching and documenting cemeteries located throughout Brazos County.

Consider and take action on the following:

- a. Consent Agenda Items 4 - 16
- b. Regular Agenda Items 17 - 24

Judge Peters announced that on request from Commissioner Brown they would be pulling items 8 and 12 from the Consent Agenda.

On motion by Commissioner Konderla and second by Commissioner Watson, the Court voted unanimously to approve Consent items 4-7, 9-11, and 13-16.

Motion: Approve, Moved by Commissioner Chuck Konderla, Seconded by Commissioner Wanda J. Watson. Passed. 5-0. Ayes: Brown, Konderla, Nettles, Peters, Watson.

4. Approval for acceptance of donated or unclaimed property items left by inmates leaving the Brazos County Detention Center for the months of March and April 2026.

A copy of the donation form is attached.

Motion: Approve, Moved by Commissioner Chuck Konderla, Seconded by Commissioner Wanda J. Watson. Passed. 5-0. Ayes: Brown, Konderla, Nettles, Peters, Watson.

5. Commissioners Court minutes for the following dates:

- May 5, 2026 Regular Meeting
- May 19, 2026 Regular Meeting
- May 20, 2026 Workshop Session

- May 26, 2026 Special Called Session

Motion: Approve, Moved by Commissioner Chuck Konderla, Seconded by Commissioner Wanda J. Watson. Passed. 5-0. Ayes: Brown, Konderla, Nettles, Peters, Watson.

6. Approval of the Treasurer's Report for April 2026.

The Court voted unanimously to receive, approve and order filed as submitted the Treasurer's report for April 2026. A copy is attached and made a part of these minutes.

Motion: Approve, Moved by Commissioner Chuck Konderla, Seconded by Commissioner Wanda J. Watson. Passed. 5-0. Ayes: Brown, Konderla, Nettles, Peters, Watson.

7. Tax Refund Applications for the following:

Overpayments

- a. Triad Financial Services - \$1,480.15

Motion: Approve, Moved by Commissioner Chuck Konderla, Seconded by Commissioner Wanda J. Watson. Passed. 5-0. Ayes: Brown, Konderla, Nettles, Peters, Watson.

8. FY 25/26 Budget Amendments 19.01 - 19.10.

Peter Michelena, resident of Precinct 4, addressed the Court concerning Amendments 19.05, 19.09, and 19.03.

County Auditor Marci Turner provided clarification on Amendments 19.05 and 19.09. Budget Officer Nina Payne provided clarification on Amendment 19.03.

Cynde Wiley, resident of Precinct 1 addressed the Court concerning accounting practices related to Amendments 19.05, and 19.09.

Judge Peters provided additional clarification.

Cathie Viens, resident of Precinct 4 addressed concerns with the Court regarding transparency related to Amendment 19.03

Project Management Director Trevor Lansdown provided clarification.

Commissioner Brown shared his continued concerns on working with local companies. Project Management Director Trevor Lansdown addressed these concerns.

Commissioner Nettles, Commissioner Konderla and Judge Peters shared that their desire is to get the best company at the best price for the County.

The Court voted unanimously to approve FY 25/26 Budget Amendments 19.01 - 19.10. A copy of the Budget Amendments is attached.

Motion: Approve, Moved by Commissioner Fred Brown, Seconded by Commissioner Chuck Konderla. Passed. 5-0. Ayes: Brown, Konderla, Nettles, Peters, Watson.

9. Permission to Advertise Bid #27-007 Cutback Asphalt.

Motion: Approve, Moved by Commissioner Chuck Konderla, Seconded by Commissioner Wanda J. Watson. Passed. 5-0. Ayes: Brown, Konderla, Nettles, Peters, Watson.

10. Approval of the following Deductive Change Orders to CIP #25-583 Brazos County Scour Repair with Solid Bridge Construction, totaling \$41,435.
- a. Harris Lane (002) - (\$15,000.00)
 - b. Fickey Road - North (001) - (\$26,435.00)

A copy of the Change Order is attached.

Motion: Approve, Moved by Commissioner Chuck Konderla, Seconded by Commissioner Wanda J. Watson. Passed. 5-0. Ayes: Brown, Konderla, Nettles, Peters, Watson.

11. Approve of the Interlocal Agreement of Surplus Property Transfer between Brazos County and Burleson County.

A copy of the Inter Local Agreement is attached.

Motion: Approve, Moved by Commissioner Chuck Konderla, Seconded by Commissioner Wanda J. Watson. Passed. 5-0. Ayes: Brown, Konderla, Nettles, Peters, Watson.

12. Approval to sell a total of 286 road and miscellaneous signs to Burleson County for a total of \$100.00 pursuant to Local Government Code §263.152. These items are no longer needed for county use.

Commissioner Brown asked for clarification on the need to sell the signs. County Engineer Prarthana Banerji provided clarification.

A copy of the Interlocal Agreement is attached.

Motion: Approve, Moved by Commissioner Chuck Konderla, Seconded by Commissioner Bentley Nettles. Passed. 4-1. Ayes: Konderla, Nettles, Peters, Watson. Nays: Brown.

13. Approval of the Community Supervision and Corrections Department Interlocal Cooperation Contract for Fiscal Year 2027.

A copy of the Interlocal Agreement is attached.

Motion: Approve, Moved by Commissioner Chuck Konderla, Seconded by Commissioner Wanda J. Watson. Passed. 5-0. Ayes: Brown, Konderla, Nettles, Peters, Watson.

14. Consider and take action on the Comcast utility permit to install 2-inch conduit by directional bore within the right-of-way of following County Roads. Sites are located in Precinct 1.
- a. I & GN Road – 727 feet in ROW and 2 crossings
 - b. Koppe Bridge Road – 2,845 feet in ROW and 6 crossings
 - c. Meadow Creek Drive – 1 crossing
 - d. Faircrest - 2 crossings
 - e. Sagewood Drive - 3 crossings
 - f. Piedmont Lane - 1 crossing
 - g. Meredith Drive - 2 crossings
 - h. Cloud Lane - 3 crossings
 - i. Arrow Crest Drive - 1 crossing
 - j. Stewart Drive - 2 crossings

Motion: Approve, Moved by Commissioner Chuck Konderla, Seconded by Commissioner Wanda J. Watson. Passed. 5-0. Ayes: Brown, Konderla, Nettles, Peters, Watson.

15. Consider and take action on the Comcast utility permit to install 2-inch conduit by directional bore within the right-of-way of following County Roads. Sites are located in Precinct 4.
- a. Silver Hill Road – 6,227 feet in ROW and 8 crossings
 - b. Bush Lane – 639 feet in ROW and 1 crossing
 - c. Leonard Road – 2,041 feet in ROW and 2 crossings

Motion: Approve, Moved by Commissioner Chuck Konderla, Seconded by Commissioner Wanda J. Watson. Passed. 5-0. Ayes: Brown, Konderla, Nettles, Peters, Watson.

16. Consider and take action on the Comcast utility permit to construct road bores under the following County Roads located within Old Spanish Trail Estates and Benchley Oaks Subdivision. Sites are located in Precinct 4.
- a. Old Spanish Trail – 10 crossings
 - b. Oak Trail – 3 crossings
 - c. Spanish Hill – 2 crossings
 - d. Redbud Drive – 1 crossing

Motion: Approve, Moved by Commissioner Chuck Konderla, Seconded by Commissioner Wanda J. Watson. Passed. 5-0. Ayes: Brown, Konderla, Nettles, Peters, Watson.

17. Proclamation 26-019 proclaiming July 4, 2026, Declaration of Independence Day and recognizing the 250th Anniversary of American Independence (America 250).

The County Judge read aloud Proclamation 26-019 proclaiming July 4, 2026 as Declaration of Independence Day and recognizing the 250th Anniversary of American

Independence.

Motion: Approve, Moved by Commissioner Bentley Nettles, Seconded by Commissioner Chuck Konderla. Passed. 5-0. Ayes: Brown, Konderla, Nettles, Peters, Watson.

18. Resolution 26-013 requesting permission to host the 2028 North and East Texas County Judges and Commissioners Conference in Bryan/College Station if selected by the committee.

The Court voted unanimously to adopt Resolution 26-013 requesting permission to host the 2028 North and East Texas County Judges and Commissioners Conference in Bryan/College Station if selected by the committee.

Motion: Approve, Moved by Commissioner Chuck Konderla, Seconded by Commissioner Wanda J. Watson. Passed. 5-0. Ayes: Brown, Konderla, Nettles, Peters, Watson.

19. Approval of addition to the Interim Compensation Administration Guidelines previously approved on June 9, 2026 regarding Promotion to Higher-Level Positions.

Cynde Wiley, resident of Precinct 1, sought clarification on the verbiage of the Interim Compensation Administrative Guidelines.

Judge Peters and Commissioner Nettles provided clarification.

A copy of the guidelines is attached.

Motion: Approve, Moved by Commissioner Chuck Konderla, Seconded by Commissioner Wanda J. Watson. Passed. 5-0. Ayes: Brown, Konderla, Nettles, Peters, Watson.

20. Request from Information Technology to approve the Artificial Intelligence Policy and Guidelines.

A copy of the policy is attached.

Motion: Approve, Moved by Commissioner Bentley Nettles, Seconded by Commissioner Chuck Konderla. Passed. 5-0. Ayes: Brown, Konderla, Nettles, Peters, Watson.

21. Request from Forensic Services - Administration for the following personnel changes with the effective date as of June 27, 2026. This change will increase the Forensic Services - Administration FY 2026 Budget in the amount of \$24,025.00.

- a. Increase B3004-1 Forensic Lab Technician, Salary Grade B3004-1, from \$0.00 per hour to \$28.26 per hour, Hourly Full-Time

Motion: Approve, Moved by Commissioner Fred Brown, Seconded by Commissioner Wanda J. Watson. Passed. 5-0. Ayes: Brown, Konderla, Nettles, Peters, Watson.

22. Approval of the following liability renewal questionnaire for Texas Association of

Counties with coverage dates of October 1, 2026 - October 1, 2027.

- a. Auto Liability
- b. Auto Physical Damage
- c. General Liability
- d. Public Officials Liability
- e. Law Enforcement Liability

Cynde Wiley, a resident of Precinct 1, requested clarification regarding the policy. Risk Management Coordinator Leslie Contreras provided an overview of the policy and explained the coverage included.

Commissioner Brown expressed concerns regarding TAC and stated that he would prefer the County solicit bids for this type of policy.

Ms. Contreras responded by outlining the additional benefits TAC provides to the County, noting that these services and resources are not available through other providers.

Commissioner Watson voiced her support for continuing coverage through TAC.

Motion: Approve, Moved by Commissioner Chuck Konderla, Seconded by Commissioner Wanda J. Watson. Passed. 5-0. Ayes: Brown, Konderla, Nettles, Peters, Watson.

23. Personnel Change of Status.

- Approval of Personnel Change of Status.

A copy Personnel Change of Status is attached.

Motion: Approve, Moved by Commissioner Chuck Konderla, Seconded by Commissioner Wanda J. Watson. Passed. 5-0. Ayes: Brown, Konderla, Nettles, Peters, Watson.

24. Payment of Claims.

- Approval of Payments of Claims.

A copy of Claims is attached.

Motion: Approve, Moved by Commissioner Chuck Konderla, Seconded by Commissioner Wanda J. Watson. Passed. 5-0. Ayes: Brown, Konderla, Nettles, Peters, Watson.

25. Acknowledgment of Personnel Change of Status.

The Court acknowledged receipt of Personnel Change of Status.

26. Acknowledgement that the Brazos County Emergency Services District #3 (ESD #3) Bond was filed with the Brazos County Clerk's Office on June 8, 2026.

The Court acknowledged that the ESD#3 Bond was filed with the Brazos County Clerk's Office on June 8, 2026.

Motion: , Moved by , Seconded by . . 5-0. Ayes: Brown, Konderla, Nettles, Peters, Watson.

27. Acknowledgement of FY 2025-2026 Budget to Actuals by Fund as of June 11, 2026. Acknowledgement of FY 2025-2026 Contingency Budget to Actuals by Fund as of June 11, 2026.

The Court acknowledged receipt of the FY 2025 - 2026 Budget to Actuals by Fund and Contingency Fund Budget to Actuals as of June 11, 2026.

28. Acknowledgement of Monthly Reports submitted in June 2026.

The Court acknowledged receipt of the Extension Service reports submitted in June 2026 and acknowledged receipt of reports from the following County and Precinct Offices showing revenues collected and remitted to the County Treasurer:

County Clerk
Constable Precinct 2
Constable Precinct 3
Constable Precinct 4
Collections

29. Quarterly Report from the Public Defender's Office.

Chief Public Defender Nathan Wood provided a brief update regarding the operations and progress of the Public Defender's Office. He reported that the office has established both a Juvenile Division and a Mental Health Division, and that both divisions are fully operational.

Mr. Wood stated that the Juvenile Division is currently handling approximately half of all juvenile appointments. Regarding staffing, he advised that the office continues to recruit for four vacant attorney positions.

Mr. Wood further reported that the Public Defender's Office currently has 612 active clients. During the current quarter, the office accepted 192 new clients and has resolved legal matters for 215 clients. These figures do not include cases handled by the Juvenile Division or the Mental Health Division. Statistics for those divisions will be provided to the Court in the next quarterly report.

30. Quarterly Report from the Juvenile Services Department.

Juvenile Services Director Linda Ricketson provided highlights from the third quarter. She reported that during the month of May, the department received 81 juvenile referrals, of which 77 involved Brazos County residents and 4 involved juveniles from outside the county. Ms. Ricketson noted that, over a three-month period, housing juveniles from other counties generated approximately \$82,000 in revenue.

Ms. Ricketson further reported that the department currently supervises 148 juveniles and has 125 cases pending before the Court. In addition, 62 juveniles are currently participating in community-based counseling services.

Ms. Ricketson expressed her appreciation to the staff for their hard work and dedication. She reported that, during a recent audit, the facility not only met all 34 required standards but exceeded the standards in nine areas.

In closing, Ms. Ricketson reported that the Art for Life Program is currently in session, with 22 juveniles participating. She announced that an open house will be held at the Kimble Building in Downtown Bryan on July 24th and 25th. Members of the Court were invited to attend a special event on July 24th at 6:00 p.m., with the program opening to the public on July 25th. Additional information regarding the event will be provided at a later date.

31. Quarterly Report from the Sheriff's Office.

Chief Deputy Kevin Stuart presented the Sheriff's Office Quarterly Report for the second quarter.

Chief Deputy Stuart reported that the Average Daily Population of the jail for the second quarter was 724 inmates, 617 were male and 107 were female, reflecting a decrease from the first quarter. During the second quarter, the Sheriff's Office processed a total of 2,325 inmate bookings. The population for today is 657 inmates.

Regarding patrol operations, Chief Deputy Stuart reported that during the month of May, deputies responded to 966 dispatched calls for service and 2,324 self-initiated calls.

32. Announcement of interest items and possible future agenda topics.

Judge Peters announced that the Court will begin utilizing the new agenda management software at the next regular meeting of the Commissioners Court on July 7, 2026.

Commissioner Nettles requested a future report from the County AgriLife Extension Agent regarding the New World Screwworm. Sheriff Dicky advised that the Sheriff's Office Livestock Unit is monitoring the situation, coordinating with the Health District, and will provide updates on the Sheriff's Office website as information becomes available.

Commissioner Brown requested a list of County-owned properties that are not currently in use for consideration of potential sale. Judge Peters noted that this information is being compiled as part of the ongoing Master Plan process.

Commissioner Konderla encouraged the community to have a safe and happy Fourth of July as the nation celebrates its 250th anniversary. He expressed gratitude for the freedoms and opportunities afforded by living in the United States and encouraged continued prayers for the Country.

33. Adjourn.

The meeting was adjourned at 11:27 a.m.



**BRAZOS COUNTY
BRYAN, TEXAS**

NOTICE OF MEETING AND AGENDA

BRAZOS COUNTY COMMISSIONERS COURT

**THE COMMISSIONERS COURT OF BRAZOS COUNTY WILL MEET
IN REGULAR SESSION ON JUNE 23, 2026 AT 10:00 AM IN THE
COMMISSIONERS COURTROOM OF THE BRAZOS COUNTY
ADMINISTRATION BUILDING, 200 S. TEXAS AVENUE, SUITE 106,
BRYAN, TX 77803**

**THE PUBLIC MAY WATCH THE MEETING LIVE ON THE BRAZOS
COUNTY COMMISSIONERS COURT YOUTUBE CHANNEL AT:
[HTTPS://WWW.YOUTUBE.COM/@BRAZOSCOUNTY3227](https://www.youtube.com/@BRAZOSCOUNTY3227).**

-
1. Invocation and Pledge of Allegiance
 - U.S. and Texas Flag - Commissioner Nettles
 2. Call for Citizen input and/or concerns
 3. Presentations and/or Discussions
 - Presentation and discussion regarding recognition of the Brazos County Historical Commission as a recipient of the 2025 Distinguished Service Award from the Texas Historical Commission.

Consider and take action on the following:

- a. Consent Agenda Items 4 - 16
 - b. Regular Agenda Items 17 - 24
4. Approval for acceptance of donated or unclaimed property items left by inmates leaving the Brazos County Detention Center for the months of March and April 2026.
 5. Commissioners Court minutes for the following dates:
 - May 5, 2026 Regular Meeting
 - May 19, 2026 Regular Meeting
 - May 20, 2026 Workshop Session
 - May 26, 2026 Special Called Session

6. Approval of the Treasurer's Report for April 2026.
7. Tax Refund Applications for the following:
 - Overpayments**
 - a. Triad Financial Services - \$1,480.15
8. FY 25/26 Budget Amendments 19.01 - 19.10.
9. Permission to Advertise Bid #27-007 Cutback Asphalt.
10. Approval of the following Deductive Change Orders to CIP #25-583 Brazos County Scour Repair with Solid Bridge Construction, totaling \$41,435.
 - a. Harris Lane (002) - (\$15,000.00)
 - b. Fickey Road - North (001) - (\$26,435.00)
11. Approve of the Interlocal Agreement of Surplus Property Transfer between Brazos County and Burleson County.
12. Approval to sell a total of 286 road and miscellaneous signs to Burleson County for a total of \$100.00 pursuant to Local Government Code §263.152. These items are no longer needed for county use.
13. Approval of the Community Supervision and Corrections Department Interlocal Cooperation Contract for Fiscal Year 2027.
14. Consider and take action on the Comcast utility permit to install 2-inch conduit by directional bore within the right-of-way of following County Roads. Sites are located in Precinct 1.
 - a. I & GN Road – 727 feet in ROW and 2 crossings
 - b. Koppe Bridge Road – 2,845 feet in ROW and 6 crossings
 - c. Meadow Creek Drive – 1 crossing
 - d. Faircrest - 2 crossings
 - e. Sagewood Drive - 3 crossings
 - f. Piedmont Lane - 1 crossing
 - g. Meredith Drive - 2 crossings
 - h. Cloud Lane - 3 crossings
 - i. Arrow Crest Drive - 1 crossing
 - j. Stewart Drive - 2 crossings
15. Consider and take action on the Comcast utility permit to install 2-inch conduit by directional bore within the right-of-way of following County Roads. Sites are located in Precinct 4.
 - a. Silver Hill Road – 6,227 feet in ROW and 8 crossings
 - b. Bush Lane – 639 feet in ROW and 1 crossing
 - c. Leonard Road – 2,041 feet in ROW and 2 crossings
16. Consider and take action on the Comcast utility permit to construct road bores under the following County Roads located within Old Spanish Trail Estates and Benchley Oaks Subdivision. Sites are located in Precinct 4.
 - a. Old Spanish Trail – 10 crossings
 - b. Oak Trail – 3 crossings
 - c. Spanish Hill – 2 crossings
 - d. Redbud Drive – 1 crossing
17. Proclamation 26-019 proclaiming July 4, 2026, Declaration of Independence Day and recognizing the 250th Anniversary of American Independence (America 250).
18. Resolution 26-013 requesting permission to host the 2028 North and East Texas

County Judges and Commissioners Conference in Bryan/College Station if selected by the committee.

19. Approval of addition to the Interim Compensation Administration Guidelines previously approved on June 9, 2026 regarding Promotion to Higher-Level Positions.
20. Request from Information Technology to approve the Artificial Intelligence Policy and Guidelines.
21. Request from Forensic Services - Administration for the following personnel changes with the effective date as of June 27, 2026. This change will increase the Forensic Services - Administration FY 2026 Budget in the amount of \$24,025.00.
 - a. Increase B3004-1 Forensic Lab Technician, Salary Grade B3004-1, from \$0.00 per hour to \$28.26 per hour, Hourly Full-Time
22. Approval of the following liability renewal questionnaire for Texas Association of Counties with coverage dates of October 1, 2026 - October 1, 2027.
 - a. Auto Liability
 - b. Auto Physical Damage
 - c. General Liability
 - d. Public Officials Liability
 - e. Law Enforcement Liability
23. Personnel Change of Status.
 - Approval of Personnel Change of Status.
24. Payment of Claims.
 - Approval of Payments of Claims.
25. Acknowledgment of Personnel Change of Status
26. Acknowledgement that the Brazos County Emergency Services District #3 (ESD #3) Bond was filed with the Brazos County Clerk's Office on June 8, 2026.
27. Acknowledgement of FY 2025-2026 Budget to Actuals by Fund as of June 11, 2026. Acknowledgement of FY 2025-2026 Contingency Budget to Actuals by Fund as of June 11, 2026.
28. Acknowledgement of Monthly Reports submitted in June 2026.
29. Quarterly Report from the Public Defender's Office.
30. Quarterly Report from the Juvenile Services Department.
31. Quarterly Report from the Sheriff's Office.
32. Announcement of interest items and possible future agenda topics.
33. Adjourn.

PUBLIC COMMENTS

Public Comment during the Commission Meeting may be for all matters, both on and off the agenda, and be limited to four minutes per person. Public participation sign-up sheets must be submitted at least five (5) minutes prior to the start of the posted meeting time. Persons are invited to submit comments in writing on the agenda items and/or attend and make comment at the Commission meeting. Members of the public are reminded that the Brazos County Commissioners Court is a Constitutional Court, with both judicial and legislative powers, created under Article V, Section 1 and Section 18 of the Texas Constitution. As a Constitutional Court, the Brazos County Commissioners Court also possesses the power to issue a Contempt of Court Citation under Section 81.023 of the Texas Local Government Code. Accordingly, members of the public in attendance at any Regular, Special and/or Emergency meeting of the Court shall conduct themselves with proper respect and decorum in speaking to, and/or addressing the Court; in participating in public discussions before the Court; and in all actions in the presence of the Court. Those members of the public who are inappropriately attired and/or who do not conduct themselves in an orderly and appropriate manner will be ordered to leave the meeting. Refusal to abide by the Court's Order and/or continued disruption of the meeting may result in a Contempt of Court Citation.

It is not the intention of the Brazos County Commissioners Court to provide a public forum for the demeaning of any individual or group. Neither is it the intention of the Court to allow a member (or members) of the public to insult the honesty and/or integrity of the Court, as a body, or any member or members of the Court, or County employees, individually or collectively. Accordingly, profane, insulting or threatening language directed toward the Court and/or any person in the Court's presence and/or racial, ethnic or gender slurs or epithets will not be tolerated. Violation of these rules may result in the following sanctions:

1. cancellation of a speaker's time;
2. removal from the Commissioners Court;
3. a Contempt Citation; and/or
4. such other and/or criminal sanctions as may be authorized under the Constitution, Statutes and Codes of the State of Texas.

The County Commissioners Court can deliberate or take action only if a matter has been listed on an agenda properly posted prior to the meeting. During the public comment period, speakers may address matters not listed on the published agenda. The Open Meeting Law does not expressly prohibit responses to public comments by the Commissioners Court. However, responses from the County Judge or Commissioners to unlisted public comment topics could become deliberation on a matter without notice to the public. To ensure the public has notice of all matters the Commissioners Court will consider, the County Judge and/or Commissioners may choose not to respond to public comments, except to correct factual inaccuracies, recite existing policy in response to an inquiry or to ask that a matter be listed on a future agenda. See Texas Open Meetings Act Section 551.042.

INVOCATION

Any invocation that may be offered before the official start of the Court meeting shall be to and for the benefit of the Court. The views or beliefs expressed by the invocation speaker have not been previously reviewed or approved by the Court and do not necessarily represent the religious beliefs or views of the Court in part or as a whole. No member of the community is required to attend or participate in the invocation and such decision will have no impact on their right to actively participate in the business of the Court.

The Commissioners Courtroom of the Brazos County Administration Building, 200 S. Texas Avenue, Suite 106, Bryan, TX 77803 is wheelchair accessible. Handicap parking spaces are available. Any request for sign interpretive services must be made two working days before the meeting. To make arrangements, please call (979) 361-4102.

BRAZOS COUNTY COMMISSIONER'S COURT

23 DAY OF June, 2026
1000 (A)M/PM, Regular Meeting

Name
(PLEASE PRINT)

Abrey Leggett

Sheryl Love

Charles Kuebler

Kathryn Battles

Wm. Charles Wendt

Rocanna McConathy

Jennifer Salazar

Tony Piccolo

MIKE STREETER

marci turner

Barbara Smith

Kim Smith

TREW LANSLOW

ERIC CALDWELL

Billy Melzow

Organization
(PLEASE PRINT)

Comm Court

Comm Court

IT

Purchasing

I

HR

HR

Pc + 2

county auditor

Co Judge

Co Judge

PROJECT MANAGEMENT

BCIT

BCIT

BRAZOS COUNTY COMMISSIONER'S COURT

23 DAY OF June, 2024
10:00 AM/PM, Regular

Name
(PLEASE PRINT)

Organization
(PLEASE PRINT)

Angela And
Katie Conner

Co. Judge
Co. Judge Asst

Jerry Monagres
Jacquelin Gaston
Cristian Villarreal

Expo
Expo
Trcas

Karen McQueen
Ashlie Peters-Bowman

Co Clerk
Co Clerk

Victoria Limon McCoy
Joe Southern

Co. Clerk
The Eagle

TORI MOSES
Cynde Wiley

WEISSER ENG & SURVEYING
SELF

Gina Masavi
LINDA Ricketson

citizen
JUV.

Andrew Wirke
HENRY MAZO

Co. Judge
BC H257. Comm

BRAZOS COUNTY COMMISSIONER'S COURT

23 DAY OF June, 2024
10:00 (AM)PM, Regular

Name
(PLEASE PRINT)

Organization
(PLEASE PRINT)

Peter Micheliene

Citizen

Paul Martinez

S.O.

Paris Pavlas

Rep. Paul Dyson

Diana Mills

Veterans

Tina Mark

Veterans / Sheriff

Wayne Dickey

S.O.

Lige A. Sieber

DAE La Villita

Karl M. Devrin

TAR La Villita

Kevin Stuart

BCSO

Rachael P. Altman

Brazos City Hist Comm

Lupe Arredondo

Cof

Jennifer Goerby

CSCD

Traci Conde

CSCD

Petra Gend

Citizen

Mary Sherrill

BEAC

BRAZOS COUNTY COMMISSIONER'S COURT

23 DAY OF June, 2024
10:00 AM PM, Regular

Name

(PLEASE PRINT)

Organization

(PLEASE PRINT)

Ivan Syrcel

NA

Hezekiah Carter Sr

Pct 4 Constable

JOE SALVATO

RTB

Prarthana Banerji

R & B

SHERY FRISK

Brazos Co Hist. Com.

Tom Niccolo

Pct 2

Chris McDermott

Pct. 2 Const

Judge Zachary

A C

Nathan Wood

PDO

Cristian Villarreal

Treas

Delia Sandoval

Comm Court

June 23, 2026

Brazos County Regular Session

Presented by:

Cathie Viens
College Station
Precinct 4

Public Comment Statement

Good morning, Judge Peters and Commissioners.

My name is Cathie Viens and I am a resident and taxpayer of Brazos County. I am standing here today to address a highly visible, and what some have said - financially reckless pattern in how this court handles capital projects. I'm here today to challenge the contradictory logic behind how our reserves are being managed.

1. The Fiscal Reality: Spending Equals Taxation

I begin with the reality that this court frequently glosses over: **every single dollar spent by this court is a dollar funded via taxation.** There is no magic pool of free county money. Unbudgeted real estate purchases and structural debt expansions directly dictate our property tax rates. When this court mismanages capital projects or hoards cash unnecessarily, the taxpayers pay the bill through their annual ad valorem tax assessments.

2. Draining Millions in Unvoted Interest

We don't have to look further than the mid-stream pivot on the 101 North Texas Avenue building. During the regular meeting on May 19th, this court argued it was "cheaper" to borrow \$38 million via Certificates of Obligation and hold onto general cash "in case of emergencies."

Since the interest debt accrued was not made known at the time of your vote on that debt, I requested it via a FOIA request. I learned that this specific Certificate of Obligation results in **\$21,668,258 in interest alone**, increasing the actual taxpayer payout to **\$57,243,258**.

This multi-million dollar interest burden **was not known or disclosed to the public** when the C.O. was originally voted on. Worse yet, this court already maintains a dedicated emergency reserve fund that was just increased in May to a **\$42 million total**. Taking out a **\$38 million loan** to act as a redundant cash buffer—while forcing taxpayers to swallow **\$21.6 million in extra interest**—is not conservative management; it is a redundant, unvoted tax penalty forced onto property owners.

3. Repeating the Playbook at San Jacinto Lane

Instead of learning from the 101 North project—which morphed from a simple renovation concept into a **\$71 million vertical mega-project** due to a lack of pre-purchase due diligence—you are repeating the exact same playbook.

You voted 3-1 to approve an unbudgeted **\$2.4 million purchase at 108 San Jacinto Lane**, paying nearly **\$1 million over the appraised value**. The court claimed a mystery competitor had an identical \$2.4 million offer, which is curious to me considering the county has no legal way of seeing confidential commercial bids.

Just like 101 North, you bought the land first and are only now starting a \$50,000 environmental and feasibility study after the contract is approved. If that study reveals poor soil, structural failures, or hidden hazards, property taxpayers will once again be forced to bail out this court's "buy first, look later" habit.

My Request to the Court

Property taxes are the direct consequence of court spending projects and management. Therefore, I am asking that this court:

- 1. Explain to the taxpayers exactly why the county needs to spend \$21 million in unvoted interest on a new \$38 million loan just to protect a \$42 million emergency fund that is already fully capitalized. Immediately adopt a strict policy banning real estate purchases prior to the formal completion of comprehensive feasibility, engineering, and environmental audits.**
- 2. Immediately end the practice of executing real estate purchases prior to the completion of comprehensive feasibility, engineering, and environmental audits.**

Stop bypassing the voters, stop hiding the true interest costs of your borrowing, and start protecting the taxpayers.

Thank you.

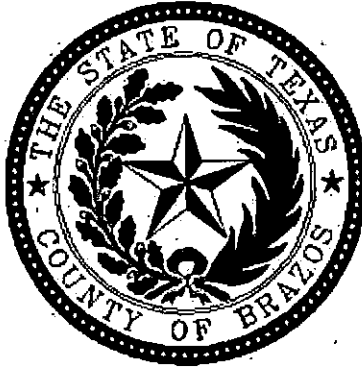

REQUEST FOR PROPOSALS

RFP NO. CIP 26-533

Brazos County – Master Plan

**SEALED PROPOSALS TO BE SUBMITTED BEFORE:
Tuesday, August 11, 2026, 2:00pm CST**

**TO THE:
BRAZOS COUNTY
PURCHASING DEPARTMENT
200 S. Texas Ave. Suite 352
Bryan, TX 77803
Phone: (979) 361-4290
Fax: (979) 361-4293**

Respondents, their employees and/or representatives are prohibited from contacting any official or employee of Brazos County, except the Purchasing Agent, regarding this solicitation from the issuing date of the solicitation until scheduled oral presentations or the date the Brazos County Commissioners Court meets to consider award of the RFP. Any such contact will be grounds for rejection of the respondents' proposal.

In compliance with this solicitation, the undersigned proposer having examined the solicitation and specifications and being familiar with the conditions to be met, hereby submits the following RFP for furnishing the material and/or services listed on the attached bid form and agrees to deliver said items at the locations and for the prices set forth on the bid form.

Company Name: _____

By (Print): _____ Title: _____

Physical Address: _____

Mailing Address: _____

Telephone: _____ Fax: _____ E-Mail: _____

A. SOLICITATION SCHEDULE

Release of RFP	_____	Tuesday, June 16, 2026
Advertisement Dates	_____	Tuesday, June 18, 2026
		Tuesday, June 25, 2026
Deadline for Questions	_____	Tuesday, August 4, 2026 at 5:00 PM CST
Proposal Submission Deadline	_____	Tuesday, August 11, 2026 at 2:00 PM CST
Review/Contract Evaluations/Negotiations	_____	August/September
Anticipated Award	_____	October

B. INTRODUCTION

The Brazos County Master Plan will serve as a twenty to twenty-five (20–25) year roadmap guiding growth, service delivery, infrastructure, and operational efficiency. The plan will align the County’s people, facilities, technology, and policies with projected demographic and economic trends to ensure effective, data-driven governance and resource stewardship. This comprehensive plan will provide both a long-term vision and short-term actionable strategies for elected officials, department heads, and staff (collectively referred to as the “Project”).

Proposals will be received by the Brazos County Purchasing Department by Tuesday, August 11, 2026, prior to 2:00 p.m. CST and publicly opened and acknowledged at the Brazos County Administration Building, 200 South Texas Avenue, Suite 352, Bryan, Texas, 77803. Proposals should be submitted in accordance with the requirements set forth herein. Late submittals will not be accepted. Each Respondent is responsible for ensuring responses to this RFP have been delivered by date, time, and location specified.

To ensure a fair and objective RFP process, all questions related to this RFP shall be submitted via the Brazos Valley e-Marketplace at <http://brazosbid.ionwave.net>. No responses will be proved to questions submitted in any other manner. The deadline for written questions and inquires is Tuesday, August 4, 2026.

The County believes that the data contained in this RFP is sufficient for the preparation of a Proposal. Requests for additional information will be considered depending on the RFP timeframe and the available of the requested information.

C. CONDITIONS OF RFP

The following instructions apply to all proposals and become a part of Terms and Conditions of any proposal submitted to the Brazos County Purchasing Department, unless otherwise specified elsewhere in this Proposal. All Contractors are required to be informed of these Terms and Conditions and will be held responsible for having done so:

1. Definitions: In order to simplify the language throughout this proposal, the following definitions shall apply:
 - a. **BRAZOS COUNTY** - Same as County.
 - b. **COMMISSIONERS' COURT** - The elected officials of Brazos County, Texas given the authority to exercise such powers and jurisdiction of all county business as conferred by the State Constitution and Laws.
 - c. **CONTRACT** - An agreement between the County and a Vendor to furnish supplies and/or services over a designated period of time during which repeated purchases are made of the commodity specified.

- d. **CONTRACTOR** - The successful Contractor(s) of this proposal request.
 - e. **COUNTY** - The government of Brazos County, Texas and its authorized representatives.
 - f. **SUB-CONTRACTOR** - Any contractor hired by the Contractor or Supplier to furnish materials and services specified in this proposal request.
 - g. **SUPPLIER** - Same as Contractor
2. Upon acceptance and approval by the Commissioners' Court, this proposal will be made part of the contract between Brazos County and the successful Contractor for the period designated.
 3. **Proposals must be received by the Purchasing Department prior to the time and date specified.**
 4. The County reserves the right to accept or reject in part or in whole, any proposals submitted, and to waive any technicalities for the best interest of the County.
 5. Brazos County shall not be responsible for any verbal communication between any employee of the County and any potential Contractor. Only written specifications and written price quotations will be considered.
 6. Brazos County reserves the right to reject any proposals that do not fully respond to each specified item.
 7. Should there be a change in ownership or management; the contract shall be canceled unless a mutual agreement is reached with the new owner to continue the contract with its present provisions and prices. This contract is nontransferable and non-assignable by either party.
 8. The County may cancel this contract at any time for any reason, provided thirty-day written notice is given.
 9. The County will follow the Texas Local Government Code, Chapter 262.030 for this RFP process. The proposals will be opened on the date and time mentioned above and only the names of the proposers will be read aloud. The proposals will be distributed to the evaluation committee and this committee will evaluate each proposal according to the criteria set forth in this RFP. The committee will determine how many of the top evaluated firms will be negotiated with depending on the scores and other factors at the discretion of Brazos County. This negotiation process may be repeated depending on the project and its complexity. All Firms will be accorded fair and equal treatment with respect to any opportunity for discussion and revision of proposals and no pricing will be shared with any of the Respondents at any time until after an award is made and contract is approved by Commissioners Court. A best and final offer will be requested including any revisions, such as a revision of the completion timeframe for inclusion into the final contract.
 - a. **Firms Experience with Civil Master Planning** **20%**
 - b. **Project Team and Subcontractor's Qualifications, Experience, Ability to Complete All Scope, and Workload** **25%**

c. Methodology, Technical Approach, and Innovation in Planning	25%
d. Demonstrated Understanding of Texas Local Government Code	5%
e. Price	30%

In the event that the County requires additional information or clarification, interviews may be conducted with selected Respondents. County staff will make a recommendation to the Commissioners Court for the final selection and award.

10. Although the cost is an essential part of the proposal, Brazos County is not obligated to award a contract on the sole basis of cost.
11. Acceptance of work provided shall be made by the County at the sole discretion of the Commissioner's Court when all terms and conditions of the contract and specifications have been met to its satisfaction, including the submission to the County of any and all documentation as may be required.
12. Title and Risk of Loss of the goods shall not pass to Brazos County until the County actually accepts and takes possession of the goods at the point or points of delivery.
13. This agreement shall be governed by the Uniform Commercial Code as adopted in the State of Texas as effective and in force on the date of this agreement.
14. No proposal may be withdrawn after opening time without acceptable reason and with the approval of Purchasing Agent.
15. Proposals will not be considered if submitted by telephone, fax, or any other means of rapid dispatch, nor will a proposal be considered if submitted to any other person or department other than specifically instructed.
16. All proposals shall be submitted in accordance with the instructions contained herein. Brazos County will not be liable for any information received through other websites or sources of information. It is the sole responsibility of the respondent to verify the accuracy of information received from sources other than Brazos County. It is recommended that the respondent check the Brazos Valley e-Marketplace (<https://brazosbid.ionwave.net>) for addenda prior to submitting their proposal.
17. There is no expressed or implied obligation for Brazos County to reimburse responding service providers for any expenses incurred in preparing proposals in response to this request.
18. **Proposals must show full company name, mailing address and telephone number and be manually signed by an authorized sales or quotation representative of the Contractor. Company name and authorized signature shall appear in each space provided. The Respondent must include Employer Identification Number or Social Security Number and signature for the proposal to be valid**
19. Proposals must be submitted on units of quantity specified. In the event of errors in extended prices the unit price shall govern. In the event of a discrepancy between the

numbers given for the price and the word form of the price, the word form shall govern. Any suggested change in quantity on the part of the bidder to secure better price or delivery is welcomed and may be given consideration provided that the bidder also bids on the quantity specified.

20. It is our policy not to furnish proposal results over the phone. Proposal results and tabulation sheets will be posted on Brazos County website after it is awarded by Commissioners Court.
21. This Proposal will be made part of any resulting contract the County may enter into. The terms and conditions of the County contained in this RFP shall supersede those of the respondent in the event of a conflict.
22. If any provision of this contract or proposal shall be held to be invalid or unenforceable for any reason, the remaining provisions shall continue to be valid and enforceable. If a court of competent jurisdiction finds that any provision of this contract or proposal is invalid or unenforceable, but that by limiting such provision it may become valid and enforceable, then such provision shall be deemed to be written, construed, and enforced as so limited. Any lawsuit will be governed by Texas law and Brazos County, Texas will be the venue for any action or proceeding that may be brought or arise out of, in connection with or by reason of this Proposal process and resulting contract.
23. No oral statements of any person shall modify or otherwise change or affect the terms, conditions or specifications. All change orders to this agreement shall be made in writing and shall not be effective unless signed by an authorized representative of Brazos County.

D. SPECIAL PROVISIONS

1. Respondent with questions regarding the proposal should submit them in writing via the Brazos Valley e-Marketplace at <https://brazosbid.ionwave.net>.
2. Fill out the proposal completely, identify the proposal name and number on the outside and return it to the Brazos County Purchasing Department, Administration Building, 200 South Texas Ave., Suite 352, Bryan, Texas 77803 prior to the submission deadline. The proposal is invalid if it is not deposited at the designated location prior to the time and date advertised, or prior extension issued by the County.
3. All proposals shall be prepared on the bid forms located on the Brazos Valley e-Marketplace County web site <https://brazosbid.ionwave.net>. The proposer must put the proposal number and name on the front of the envelope before mailing it to the Purchasing Department.
4. During the evaluation process, Brazos County reserves the right, in the best interest of the County, to request additional information or clarification from Contractors.
5. The contract shall be awarded to the responsible Contractor whose proposal is determined to be the best evaluated offer.

6. Responses to this proposal should be clear and concise addressing all requirements listed above and any other factors not specifically mentioned which would be advantageous to Brazos County.

E. TRADE SECRETS, CONFIDENTIAL INFORMATION AND THE TEXAS PUBLIC INFORMATION ACT

1. Brazos County, Texas is subject to the Texas Publication Information Act, Chapter 552, Texas Government Code. Proposals submitted to Brazos County, Texas in response to this RFP are subject to release by the County as public information. If the Proposer believes that the Proposal response, or part of it are confidential, as proprietary information, (s)he must specify that either all or part is excepted and provide specific and detailed justification for its claim of confidentiality. Vague and general claims to confidentiality are not acceptable. All Proposals or parts of the Proposals which are not marked as confidential will be considered public information after a contract has been awarded. The successful Proposal may be considered public information even though parts are marked confidential.
2. Brazos County, Texas assumes no responsibility for asserting legal arguments on behalf of the Respondents. Respondents are advised to consult with their legal counsel concerning disclosure issues resulting from this proposal process and to take precautions to safeguard trade secrets and other proprietary information.
3. Marking your entire Proposal CONFIDENTIAL/PROPRIETARY is not in conformance with the Texas Public Information Act.
4. The requirements of Subchapter J, Chapter 552, Government Code, may apply to this contract and the contractor agrees that the contract can be terminated if the contractor knowingly or intentionally fails to comply with a requirement of that subchapter. This provision is mandatory and may not be altered or deleted, as required by Sec. 552.372(b) of the Texas Government Code.

F. CONFLICT OF INTEREST

1. The Respondent shall not offer or accept gifts or anything of value nor enter into any business arrangement with any employee, official, or agent of Brazos County.
2. By signing and executing this Proposal, the Respondent certifies and represents to the County the Proposer has not offered, conferred or agreed to confer any pecuniary benefit or other thing of value for the receipt of special treatment, advantage, information, recipient's decision, opinion, recommendation, vote or any other exercise of discretion concerning this Proposal.
3. With the exception of interviews and other contacts initiated by Brazos County relevant to the selection process, Proposers, their employees or representatives, are prohibited from contacting any official or employee of Brazos County, except the Purchasing Agent, in regard to this RFP from the issuing date of the RFP until the date the Brazos County Commissioner's Court meets to consider award of the Proposal. Any such contact will be grounds for rejection of the respondent's proposal.

G. ADDENDA AND MODIFICATIONS

1. Any changes, additions or clarifications to the RFP will be made by numbered addenda and must be acknowledged in the Proposal.
2. Any firm in doubt as to the meaning of any part of these requirements may request an interpretation thereof from the Purchasing Agent. At the request of the Proposer, or in the event the Purchasing Agent deems the interpretation to be substantive, the interpretation will be made by written addendum issued by the Purchasing Department. Such addendum will be posted on the Brazos Valley e-Marketplace and will become a part of the Proposal package, having the same binding effect as provisions of the original Proposal. No verbal explanation or interpretations will be binding. In order to have a request of interpretation considered, the request must be submitted in writing and must be received by the Purchasing Department no later than the question deadline.
3. All addenda, amendments, and interpretations of this solicitation shall be in writing. Brazos County shall not be legally bound by any amendment or interpretation that is not in writing. Only information supplied by the County in writing or in this RFP should be used in preparing Proposal responses.
4. The County does not assume responsibility for receipt of any addendum sent to Proposers.
5. All addenda must be acknowledged on this form.
6. The Commissioner's Court delegated the right and responsibility for issuing any and all addenda to the Purchasing Agent.

H. EXAMINATION OF DOCUMENTS AND REQUIREMENTS

1. Each Proposer shall carefully examine all RFP documents and be thoroughly familiar with all requirements prior to submitting a Proposal.
2. Before submitting a Proposal, each Proposer shall be responsible for making all investigations and examinations that are necessary to ascertain conditions and requirements affecting the requirements of the RFP. Failure to make such investigations and examinations shall not relieve the Proposer of the obligation to comply, in every detail, with all provisions and requirements of the RFP.

I. TAXES

Brazos County is tax exempt. Tax exemption certificates will be executed by the County upon request.

J. INSURANCE

The Contractor shall procure and maintain at its sole cost and expense for the duration of this Agreement insurance against claims for injuries to persons or damages to property that may arise from or in connection with the performance of the work hereunder by the Contractor, its agents, representatives, volunteers, employees or subcontractors. The Contractor's insurance coverage shall be primary insurance with respect to the County, its officials, employees and volunteers. Any insurance or self-insurance maintained by the County, its officials, employees or volunteers

shall be considered in excess of the Contractor's insurance and shall not contribute to it. Further, the Contractor shall include e all subcontractors as additional insured under its policies or shall furnish separate certificates and endorsements for each subcontractor. All coverage for subcontractors shall be subject to all of the requirements stated herein. **All Certificates of Insurance and endorsements shall be furnished to the County's Representative and approved by the County before work commences.**

Standard Insurance Policies Required:

- a. Commercial General Liability Policy
- b. Automobile Liability Policy
- c. Worker's Compensation Policy
- d. Professional Liability

General Requirements applicable to all policies:

- a. Only insurance carriers licensed and admitted to do business in the State of Texas will be accepted.
- b. Deductibles shall be listed on the Certificate of Insurance and are acceptable only on a per occurrence basis for property damage only.
- c. "Claims Made" policies will not be accepted.
- d. Each insurance policy shall be endorsed to state that coverage shall not be suspended, voided, canceled, reduced in coverage or in limits except after thirty (30) days prior written notice by certified mail, return receipt requested, has been given to Brazos County.
- e. All insurance policies shall be furnished to Brazos County upon request.

1. COMMERCIAL GENERAL LIABILITY

- a. General Liability insurance shall be written by carrier with an A:VIII or better rating in accordance with the current Best Key Rating guide.
- b. Minimum Combined Single Limit of \$1,000,000.00 per occurrence for bodily injury and property damage.
- c. No coverage shall be deleted from the standard policy without notification of individual exclusions being attached for review and acceptance.
- d. Excess Liability Umbrella Policy in the amount of not less than \$2,000,000.00 will be provided at the Contractors expense.
- e. Brazos County shall be named as additional insured on Contractors insurance. "Texas Waiver of Our Right to Recover From Others Endorsement" shall be included in this policy. (Waiver of Subrogation)

2. AUTOMOBILE LIABILITY

- a. General Liability Insurance shall be written by a carrier with an A:VIII or better rating in accordance with the current Best Key Rating Guide.
- b. Minimum Combined Single Limit of \$1,000,000.00 per occurrence for bodily injury and property damage.

3. WORKER'S COMPENSATION INSURANCE

Pursuant to the requirements set forth in Title 28, Section 110.110 of the Texas compensation insurance policy; either directly through their employer's policy (the Contractor's or subcontractor's policy) or through an executed coverage agreement on an

approved TWCC form. Accordingly, if a subcontractor does not have his or her own policy and a coverage agreement is used, Contractors and subcontractors *must* use that portion of the form whereby the hiring contractor agrees to provide coverage to the employees of the subcontractor. The portion of the form that would otherwise allow them not to provide coverage for the employees of an independent contractor may not be used.

The worker's compensation insurance shall include the following terms:

- a. Employer's Liability limits of \$500,000.00 for each accident is required.
- b. "Texas Waiver of Our Right to Recover From Others Endorsement" shall be included in this policy. (Waiver of Subrogation)

Pursuant to the explicit terms of Title 28, Section 110.110 (c) (7) of the Texas Administrative Code, the bid specifications, this Agreement, and all subcontracts on this Project must include the following terms and conditions in the following language, without any additional words or changes, except those required to accommodate the specific document in which they are contained or to impose stricter standards of documentation:

a. Definitions:

- i. Certificate of coverage ("certificate") - A copy of a certificate of insurance, a certificate of authority to self-insure issued by the Texas Worker's Compensation Commission, or a coverage agreement (TWCC-81), TWCC-83, or TWCC-84), showing statutory worker's compensation insurance coverage for the person's or entity's employees providing services on a project, for the duration of the project.
 - ii. Duration of the project - includes the time from the beginning of the work on the project until the Contractor's/person's work on the project has been completed and accepted by the governmental entity.
 - iii. Persons providing services on the project ("subcontractors" in section 406.096 {of the Texas Labor Code}) - includes all persons or entities performing all or part of the services the Contractor has undertaken to perform on the project, regardless of whether that person has employees. This includes, without limitation, independent Contractors, subcontractors, leasing companies, motor carriers, owner-operators, employees of any such entity or employees of any entity which furnishes persons to provide services on the project. "Services" include, without limitation, providing, hauling, or delivering equipment or materials, or providing labor, transportation, or other service related to a project. "Services" does not include activities unrelated to the project, such as food/beverage vendors, office supply deliveries, and delivery of portable toilets.
- b. The Contractor shall provide coverage, based on the proper reporting of classification codes and payroll amounts and filing of any coverage agreements, that meets the statutory requirements of Texas Labor Code, Section 401.011 (44) for all employees of the Contractor providing services on the project, for the duration of the project.
 - c. The Contractor must provide a certificate of coverage to the governmental entity prior to being awarded the contract.

- d. If the coverage period shown on the Contractor's current certificate of coverage ends during the duration of the project, the Contractor must, prior to the end of the coverage period, file a new certificate of coverage with the governmental entity showing that coverage has been extended.
- e. The Contractor shall obtain from each person providing services on a project, and provide to the governmental entity:
 - i. a certificate of coverage, prior to that person beginning work on the project, so the governmental entity will have on file providing services on the project, and certificates of coverage showing coverage for all person; and
 - ii. no later than seven calendar days after receipt by the Contractor, a new certificate of coverage showing extension of coverage, if the coverage period shown on the current certificate of coverage ends during the duration of the project.
- f. The Contractor shall retain all required certificates of coverage for the duration of the project and for one year thereafter.
- g. The Contractor shall notify the governmental entity in writing by certified mail or personal delivery, within 10 calendar days after the Contractor knew or should have known, or any change that materially affects the provision of coverage of any person providing services on the project.
- h. The Contractor shall post on each project site a notice, in the text, form and manner prescribed by the Texas Workers' Compensation commission, informing all persons providing services on the project that they are required to be covered, and stating how a person may verify coverage and report lack of coverage.
- i. The Contractor shall contractually require each person with whom it contracts to provide services on a project, to:
 - i. provide coverage, based on proper reporting of classification codes and payroll amounts and filing of any coverage agreement, that meets the statutory requirements of Texas Labor Code, Section 401.011 (44) for all of its employees providing services on the project, for the duration of the project;
 - ii. provide to the Contractor, prior to that person beginning work on the project, a certificate of coverage showing that coverage is being provided for all employees of the person providing services on the project, for the duration of the project;
 - iii. provide the Contractor, prior to the end of the coverage period, a new certificate of coverage showing extension of coverage, if the coverage period shown on the current certificate of coverage ends during the duration of the project.
 - iv. obtain from each other person with whom it contracts, and provide to the Contractor:
 - (a) a certificate of coverage, prior to the other person beginning work on the project; and
 - (b) a new certificate of coverage showing extension of coverage, prior to the end of the coverage period, if the coverage period shown on the current certificate of coverage ends during the duration of the project;
 - v. retain all required certificates of coverage on file for the duration of the project and for one year thereafter;
 - vi. notify the governmental entity in writing by certified mail or personal delivery, within 10 calendar days after the person know or should have known, of any

- change that materially affects the provision of coverage of any person providing services on the project; and
- vii. contractually require each person with whom it contracts, to perform as required by paragraphs (a)-(g), with the certificates of coverage to be provided to the person for whom they are providing services.
 - j. By signing this contract, or providing, or causing to be provided a certificate of coverage, the Contractor who will provide services on the project will be covered by workers' compensation coverage for the duration of the project, that the coverage will be based on proper reporting of classification codes and payroll amounts, and that all coverage agreements will be filed with the appropriate insurance carrier, or, in the case of a self-insured, with the commission's Division of Self-Insurance regulation. Providing false or misleading information may subject the Contractor to administrative penalties, criminal penalties, civil penalties, or other civil actions.

4. PROFESSIONAL LIABILITY

- a. Professional Liability with a minimum limit of \$1,000,000.00
- b. "Texas Waiver of Our Right to Recover From Others Endorsement" shall be included in this policy. (Waiver of Subrogation)

5. CERTIFICATES OF INSURANCE

Certificates shall be prepared and executed by the insurance company or its authorized agent, and shall contain the following provisions and warranties:

- a. The company is licensed and admitted to do business in the State of Texas.
- b. The insurance policies provided by the insurance company are underwritten on forms that have been provided by the Texas State Board of Insurance or ISO.
- c. All endorsements and insurance coverage according to requirements and instructions contained herein.
- d. The form of the notice of cancellation, termination, or change in coverage provisions to Brazos County.
- e. Original endorsements affecting coverage required by the section shall be furnished with the certificates of insurance.

K. COMPLIANCE WITH LAW

The Contractor's work and materials shall comply with all state and federal laws, municipal ordinances, regulations, and directions of inspectors appointed by proper authorities having jurisdiction.

The Contractor shall perform and require all subcontractors to perform the work in accordance with applicable laws, codes, ordinances, and regulations of the State of Texas and the United States and in compliance with OSHA and other laws as they apply to its employees. In the event any of the conditions of the specifications violate the code for any industry, then such code conditions shall prevail. The County has approval rights over the use and/or removal of all subcontractors and/or vendor(s).

Proposals will comply with all federal, state, county, and local laws concerning this type of project and the fulfillment of all ADA requirements

All Respondents will provide any and all notices as may be required under the Drug-Free Workplace Act of 1988, 28 CFR Part 67, Subpart F, to their employees and all sub-contractors to insure that the County maintains a drug free workplace.

L. INDEMNITY

The Contractor agrees to and shall indemnify, hold harmless, and defend the County, its officers, agents, and employees from and against any and all claims, losses, damages, causes of action, suits, and liability of every kind, including all expenses of litigation, court costs, and attorney's fees for injury to or death of any person, for damage to any property, or for any breach of contract, arising out of or in connection with the work done by the Contractor under this Contract, provided that any such claim, loss, damage, cause of action, suit or liability is caused in whole or in part by an act or omission of the Contractor, any subcontractor, or any person, organization directly or indirectly employed by any of them to perform or furnish work on the Project.

Contractor's duty to defend, indemnify and hold Brazos County harmless shall be absolute. It shall not abate or end by reason of the expiration or termination of any contract unless otherwise agreed by Brazos County in writing. The provisions of this section shall survive the termination of the Contract and shall remain in full force and effect with respect to all such matters no matter when they arise.

In the event of any dispute between the parties as to whether a claim, demand, suit, action, proceeding, lien or judgment appears to have been caused by or appears to have arisen out of or in connection with acts or omissions of Contractor, Contractor shall never-the-less fully defend such claim, demand, suit, action, proceeding, lien or judgment until and unless there is a determination by a court of competent jurisdiction that the acts and omissions of Contractor are not at issue in the matter.

Contractor's indemnification shall cover, and Contractor agrees to indemnify Brazos County, in the event Brazos County is found to have been negligent for having selected Contractor to perform the work described in this request.

The provision by Contractor of insurance shall not limit the liability of Contractor under an agreement.

Loss Deduction Clause – Brazos County shall be exempt from, and in no way liable for, any sums of money which may represent a deductible in any insurance policy. The payment of deductibles shall be the sole responsibility of Contractor and/or trade contractor providing such insurance.

M. RELEASE

Contractor hereby releases the County, its officers, agents, representatives, and employees, from and against, and waive any and all rights to, any and all claims and/or demands for damages (personal or property), injury (including death), it/they may have concerning the Project and/or any other act and/or omission relating, directly or indirectly, to the Project, in whole or in part, as provided by the Contract, except to the extent any such claims arise due to, or damages are caused by, the negligence, breach of the Contract, or willful misconduct of the County or its authorized officers, agents, representatives, or employees.

N. SCOPE OF WORK (SOW)

The SOW below is what the Brazos County is anticipating from the Master Plan by the contractor as the end result.

1. Core Planning Elements

a. Mission, Principles, and Strategic Goals

The consultant shall work collaboratively with Commissioners Court, elected officials, department heads, and key County leadership to help establish a unified, long-range strategic foundation for Brazos County. This includes development or refinement of a mission statement, guiding principles, and clearly defined strategic goals that reflect both current needs and anticipated long-term growth and service demands. This strategic foundation shall guide decision-making across budget development, facilities planning, staffing, investments, technology adoption, service alignment, and organizational readiness. The resulting strategic direction must be implementable, measurable, and realistically tailored to the structure and statutory limitations of Texas county government, ensuring the Master Plan is rooted in governance reality, not theoretical planning rhetoric.

b. Population and Demographic Growth

The consultant shall prepare a comprehensive demographic and population analysis that evaluates projected growth over a twenty to thirty year horizon. This analysis shall rely primarily on credible and established population projections and datasets produced by recognized public agencies and research institutions, including the Texas Demographic Center, U.S. Census Bureau, regional planning organizations such as the Bryan/College Station Metropolitan Planning Organization, Texas A&M University–related research influences, and other relevant governmental or academic sources. The consultant’s role shall focus on synthesizing and validating these projections and translating them into practical implications for Brazos County operations, facilities, infrastructure, staffing, and long-range planning rather than duplicating existing population forecasting efforts. In addition to overall population growth, the analysis shall identify how demographic shifts—including age distribution, workforce trends, migration patterns, and university-related population dynamics—may influence demand for County services such as law enforcement, judicial capacity, administrative support, social services, infrastructure, and quality-of-life amenities. The consultant shall benchmark Brazos County not only against current peer counties but also against Texas counties that represent the future scale and service complexity Brazos County is projected to reach, enabling County leadership to better understand how county operations, governance structures, and service expectations evolve as population grows.

c. Departmental Space & Operational Needs

The consultant shall evaluate current and future departmental needs with a holistic approach that integrates operational functionality, staffing growth, workload capacity, and space utilization. This shall include identifying current operational constraints

and forecasting future workload pressures, and how facilities and staffing levels should evolve to adequately support efficient County service delivery. The outcome shall include phased space-needs programs and operational readiness strategies at key population and planning intervals (e.g., five, ten, twenty, thirty years). Special consideration should be given to opportunities for consolidation, shared service environments, improved collaboration between departments, and centralized storage and records strategies where practical. The resulting recommendations must be presented in clear, practical terms that leadership, staff, and the public can easily understand. The Brazos County Detention Center and Brazos County Expo Complex facilities and departments will not be part of this effort, as those departments and facilities are being covered by separate planning efforts which will be combined with this deliverable once completed.

d. Facilities & Real Estate

The consultant shall assess Brazos County's facilities and real estate portfolio, including all County-owned parcels, to determine the County's ability to support future operations, population growth, service delivery, and strategic objectives. Rather than duplicating detailed engineering condition assessments, this evaluation shall focus on functional suitability, long-term adaptability, workspace effectiveness, co-location opportunities, and strategic positioning of facilities and land assets relative to projected growth patterns and mobility corridors.

The consultant shall:

- i. Inventory County-owned facilities and parcels and evaluate their long-term strategic value based on population and demographic projections.
- ii. Identify opportunities for facility consolidation, repurposing, campus-style planning, or phased expansion aligned with future service demands.
- iii. Identify underutilized or misaligned properties that may be candidates for repurposing or potential disposition where they do not support long-term County objectives.
- iv. Assist the County in identifying future land acquisition needs, including general locations or parcels that should be considered to support anticipated facilities, services, and infrastructure as the County grows.

All recommendations shall be grounded in population and growth forecasting and consider service delivery needs, geographic equity, transportation access, and long-term fiscal sustainability. Through this effort, the consultant shall help Brazos County answer the question: "Do we have the right facilities and land, in the right places, to support the County we are becoming?"

e. Technology, AI, and Business Process Improvement

The consultant shall review Brazos County's technology environment, digital capabilities, process workflows, and emerging modernization opportunities. This includes assessing how well current systems support transparency, accountability, efficiency, and service expectations, and where modernization, integration, or automation could improve outcomes. The consultant shall evaluate opportunities for

responsible AI and automation implementation, identify cybersecurity resiliency considerations, and evaluate existing business processes to identify gaps, inefficiencies, duplication, and risk, with detailed department-level documentation addressed under Section 1. The goal is not strictly technical — it is operational — ensuring technology serves as a tool for improved decision-making, workload management, public accessibility, and employee effectiveness. Exhibit A - Brazos County Existing Software Systems is attached to have an idea of what the County currently has in place currently.

f. **Organizational Efficiency & Workforce Alignment**

The consultant shall evaluate organizational structure, staffing alignment, departmental capacity, and overall operational efficiency relative to similar counties today and counties that represent Brazos County's projected future size and complexity. This evaluation should determine whether staffing levels, skills, and organizational structure are appropriately aligned with expected service demand. Recommendations shall identify opportunities for improved efficiency, cross-training, workload balancing, organizational resilience, and structural clarity, while prioritizing enhanced capability, clarity, and service quality to ensure resources remain aligned with evolving service demands. The County's recently completed and attached Exhibit B - Compensation and Benefits study, shall be provided as backup documentation.

g. **Financial Planning**

The consultant shall develop a financial framework that aligns long-range needs with responsible and sustainable funding strategies. This shall include development of a capital improvement and investment strategy tied to population thresholds, growth indicators, and service triggers. Recommendations should include realistic funding options such as bonds, certificates of obligation, grants, partnerships, and phased implementation strategies. The financial component of the plan should serve as a decision-support and policy tool to guide long-term fiscal planning rather than a standalone cost projection. Exhibit C - Brazos County Capital Improvements Program for Fiscal Years 2026-2030 is attached to see what we currently have in place.

h. **Governance, Statutory, and Policy Review**

The consultant shall review Brazos County's planning framework and resulting recommendations through the lens of Texas Local Government Code and other applicable statutory requirements that define what counties can and cannot do. The plan should ensure all recommendations are consistent with Texas county governance realities and identify any needed policy or procedural updates to support improved alignment with best practices. The consultant should help identify where Brazos County may have blind spots, procedural gaps, or opportunities to enhance governance processes. The County's most recent adopted budget shall be provided as reference documentation. Exhibit D - Brazos County, Texas Adopted Budget for

Fiscal Year 2026 is attached to see our current budget. Exhibit E - Existing Brazos County Policies is attached to see our current policies in place in the County.

i. **Transparency and Public Communications**

The consultant shall develop strategies for open communication, including public dashboards, citizen updates, and consistent reporting. Recommend frameworks for sharing plan progress and data to improve transparency and community trust. Consultant shall propose an engagement approach that includes meaningful collaboration with Commissioners Court, elected officials, internal stakeholders, and appropriate external partners. Engagement requirements are intentionally flexible to allow proposer creativity while ensuring broad input and transparency.

j. **Resource Management & Sustainability**

The consultant shall evaluate opportunities for Brazos County to responsibly manage natural resources, reduce long-term facility energy costs, improve sustainability practices, and strengthen operational resilience. This includes reviewing opportunities for energy efficiency, reduced utility dependency, responsible land stewardship, and improved environmental performance where practical. The consultant shall review the attached Exhibit F - Brazos County Facility Design Guidelines for construction and suggest modifications in line with the findings from the above effort.

k. **Future Service & Departmental Offerings**

The consultant shall evaluate additional departments, services, and regulatory functions that Brazos County may need or have the authority to establish as population growth continues. Grounded in population and demographic forecasting and informed by benchmarking against peer and aspirational Texas counties, this analysis shall assess the feasibility, timing, and implications of expanding County responsibilities and potential Public Private Partnerships (PPP) to meet these needs, including a County Fire Marshal's Office, County Parks and Recreation, County-operated or County-supported mental and public health facilities, and other services commonly assumed by growing counties.

The consultant shall identify population or service-demand trigger points, evaluate statutory authority and governance considerations, assess operational, staffing, facility, and financial impacts, and recommend a phased timeline for when new services, departments, or regulatory functions should be considered. This effort shall also address future permitting and regulatory requirements the County may need to adopt or expand as growth continues, including development, inspection, public safety, environmental, and floodplain-related permitting authorized under Texas law.

The outcome shall be a forward-looking services and governance roadmap that enables Brazos County to proactively plan for expanded responsibilities and align future services with demonstrated need as the County continues to grow.

1. **Business Continuity, Operational Resilience, and Emergency Preparedness**

The consultant shall evaluate Brazos County's ability to maintain essential operations and service delivery during disruptions, emergencies, or adverse events. This effort shall include a department-by-department business process mapping exercise to document how critical functions are performed, identify dependencies, vulnerabilities, and single points of failure, and assess operational resilience across the organization.

Using this process-level understanding, the consultant shall develop business continuity and disaster recovery strategies tailored to County operations, including considerations related to staffing, facilities, technology systems, data access, transportation, and interdepartmental coordination. Documented processes shall also serve as an operational reference to support onboarding and knowledge transfer for newly elected officials, department heads, and employees. Deliverables shall include both narrative descriptions and technical workflow diagrams.

m. **Performance Metrics and Evaluation Framework**

The consultant shall develop a practical implementation roadmap and measurable performance framework to ensure the Master Plan functions as a living, operational tool rather than a static document. This framework shall focus on tracking progress toward adopted strategic goals, monitoring implementation milestones, and measuring the effectiveness of plan-related initiatives over time.

Recommended metrics shall relate specifically to Master Plan objectives, capital planning phases, service expansion triggers, and strategic outcomes — not individual employee performance. The consultant shall propose accountability structures, update intervals, and realistic implementation pacing to support sustained plan execution.

The consultant shall assist Brazos County in establishing a repeatable structure for reviewing, updating, and managing progress of the Master Plan over time, ensuring it remains responsive to population growth, fiscal realities, and evolving service demands.

n. **Engagement and Coordination**

The consultant will engage elected officials, department heads, and key staff through structured interviews, workshops, and public meetings. Public engagement shall include surveys and open forums. Coordination will occur regularly with the County Engineer, Budget Office, Project Management Office, and municipalities throughout the project's 12–18 month timeline.

2. **Project Timeline**

- a. Months 1–3: Data collection, demographic analysis, and stakeholder engagement
- b. Months 4–6: Departmental needs and facilities assessment
- c. Months 7–9: Benchmarking, forecasting, and operational review
- d. Months 10–12: Draft Master Plan development and financial modeling

- e. Months 13–15: Public engagement, revisions, and presentation
- f. Months 16–18: Final adoption and implementation roadmap

3. Deliverables

- a. Mission, Principles, and Strategic Goals Framework
- b. Population & Demographic Growth Forecast Report
- c. Departmental Needs Assessment and Space Program
- d. Facilities & Real Estate Assessment and Utilization Analysis
- e. Technology, AI, and Business Process Report
- f. Organizational Efficiency & Workforce Alignment Study
- g. Financial Planning Study
- h. Governance, Statutory, and Policy Compliance Review
- i. Transparency and Public Communication Report
- j. Resource Management & Sustainability Plan
- k. Future Service and Departmental Offering Plan
- l. Business Continuity, Operational Resilience, & Emergency Preparedness Plan
- m. Performance Metrics and Evaluation Framework
- n. Comprehensive Master Plan Document integrating all findings
- o. Presentation materials for Commissioners Court and public engagement sessions

O. PROPOSAL SUBMITTAL

1. The Proposer shall submit the proposal on the forms enclosed on the Brazos County web site. All blank spaces in forms shall be correctly filled in by typewriter or manually in ink and the proposer shall state the prices.
2. If a proposal is submitted by an individual, their name must be signed by them or their duly authorized agent. If the proposal is submitted by a firm, association, or partnership, the name and address of each member must be given, and the proposal must be signed by an official or duly authorized agent.
3. **The Proposer shall submit one (1) original of completed RFP with appropriate signature(s) along with a digital copy. This should include any pricing, references, specified qualifications, etc.**
4. All submittals shall be submitted in sealed envelopes bearing the name of the Respondent(s), their address, and labeled “**RFP #26-533 Brazos County – Master Plan**”. It is the sole responsibility of the Respondent to ensure that the submittal is received in a timely manner. Any submittals received after the scheduled closing time for receipt of submittals will be returned to the Respondent(s) unopened.
5. No conversations are allowed with any potential evaluation committee member and/or Commissioner. Any person pursuing a conversation regarding this RFP will be subject to disqualification.
6. By signing the certification below, the respondent verifies that all plans and specifications have been reviewed and are considered in the pricing attached. Prior to award, the respondent also completes the Verification of No Delinquent Taxes or Fees form (V.T.C.A. LOCAL GOVERNMENT CODE §262.0276), Legislative Certification

Form, and the Disclosure of Interested Parties (1295). These are all available on the Brazos County Purchasing website.

7. **The following items should be completed and included in your proposal submission. Failure to include these items will disqualify your proposer.**
 - a. **Completed and signed RFP including:**
 - i. **Response to each requirement below (Section O.,8.)**
 - ii. **Pricing (Section P)**
 - iii. **References (Section R)**
 - iv. **Certification of Proposal (Section U)**
8. A specific response is required for each of the following sections and should include the information described below. Failure of a responding Firm to submit a completed "Request for Proposal" will render the Respondent's submittal to be deemed non-responsive and it will be rejected.

Section 1 – Firm's Experience with Civil Master Planning (20 Points)

- a. Name of firm, address, phone number, and email.
- b. Form a business organization (individual, partnership, etc.).
- c. Year business was founded.
- d. Briefly state your Firm's understanding for the services to be performed and make a positive commitment to providing the services as specified in the Scope of Work.
- e. State your firm's experience with civil master planning, preferences given to work done in Texas, whether it be City, County, or State related along with the reference from those projects, in Section R. References.
- f. The letter shall be signed by a corporate officer or other individual who has the authority to bind the Firm. The name and title of the individual(s) signing the solicitation shall be clearly shown immediately below the signature.

Section 2 – Project Team Qualifications, Experience, Ability to Complete All Scope, and Workload (25 Points)

Provide detailed information on Firm's experience with providing services as described in the Scope of Work.

- a. List the number of employees in your firm.
- b. Identify the personnel who will perform each Scope of Work elements, including any planned subcontractors and their team. Resumes shall be included for each individual and subcontractor personnel and the qualifications, experience, ability to complete the scope they are associated with, and current workloads.
- c. List and include, in detail, the projects that each individual personnel and all subcontractors personnel have worked on with civil master planning in Texas.

Section 3 – Methodology, Technical Approach, and Innovation in Planning (25 Points)

Provide a detailed method of how your firm will complete each task contained in the Scope of Work within the eighteen (18) month deadline. This should include a detailed written explanation including a designation of what personnel prime or subcontractor will be involved in each task. Provide examples of past projects that included innovative strategies that are implemented and demonstrated efficiencies or other benefits.

Section 4 – Demonstrated Understanding of Texas Local Government Code (5 Points)

Provide how you plan to accomplish comparing the policies and procedures with the Texas Local Government Code along with a sample report of what we can anticipate as a result.

Section 5 – Price (30 Points)

Pricing should be itemized out, per deliverable requested in Section N. Pricing must be entered into **P. PRICING** below. Along with this section, submit a payment schedule based on major milestones. The County may entertain and negotiate a payment structure that includes monthly administration fees or other avenues but must not exceed the price per category. The County will not make any payment prior to completion and County acceptance of any agreed upon deliverables.

P. PRICING

Pricing should be detailed out to have the county select options based on the Scope of Work provided. Brazos County reserves the right to award any single or combination of tasks as itemed out below to customize the best plan based on costing, budget, and priorities.

The County will withhold five percent (5%) of the total amount of each approved progress payment as retainage. Retainage will be held to ensure satisfactory performance and completion of all awarded work completed. Retainage will be released upon final acceptance of all awarded work, submission of all required documentation, and verification that all contractual obligations have been fully met. The Contractor shall not invoice for the retained amounts prior to final written acceptance by the County.

1.	Core Planning Elements	\$
2.	Mission, Principles, and Strategic Goals	\$
3.	Population and Demographic Growth	\$
4.	Departmental Space and Operational Needs	\$
5.	Facilities and Real Estate	\$
6.	Technology, AI, and Business Process Improvement	\$
7.	Organizational Efficiency and Workforce Alignment	\$
8.	Financial Planning	\$
9.	Governance, Statutory, and Policy Review	\$
10.	Transparency and Public Communications	\$

11.	Resource Management and Sustainability	\$
12.	Future Services & Departmental Offerings	\$
13.	Business Continuity, Operational Resilience, & Emergency Preparedness	\$
14.	Performance Metrics and Evaluation Framework	\$
15.	Engagement and Coordination	\$
16.	Total for all pieces of the SOW (1-15)	\$
17.	Discount (if any) if awarded all pieces of the SOW	%

Q. CONTRACT

If chosen as the awarded firm for this project, you will be asked to compete and sign Exhibit G – Brazos County Consultant Contract.

R. REFERENCES

Respondents shall provide a list of at least five (5) references, county, city, or governmental preferred, where work comparable in quality and scope to that specified has been performed within the past five (5) years. This list should include the **names, phone number and email** of the company/entity for which the prior work was performed to contact these references. References received on previous solicitations for similar size and scope in the previous six (6) months may be considered in lieu of obtaining a new reference check. A negative reference may be grounds for disqualification of bid. Respondents are not allowed to use Brazos County as a reference.

Company/Entity: _____

Contact: _____

Phone: _____

Email: _____

--

Company/Entity: _____

Contact: _____

Phone: _____

Email: _____

--

Company/Entity: _____

Contact: _____

Phone: _____

Email: _____

Company/Entity: _____

Contact: _____

Phone: _____

Email: _____

Company/Entity: _____

Contact: _____

Phone: _____

Email: _____

S. PROPOSAL EVALUATION WAIVER

By submitting a proposal or response, each Proposer/offeror indicated below agrees to waive any claim it has or may have against Brazos County (the Owner), Architect, Engineers, Consultants and their respective Commissioners, directors, employees, or agents arising out of or in connection with (1) the administration, evaluation, or recommendation of any proposal or response (2) any requirement under the Request for Proposal or related documents; (3) the rejection of any proposal or response or any part of any proposal or response; and/or (4) the award of a Contract, if any.

The Proposer further agrees the Owner reserves the right to waive any requirements under the proposal documents or the Contract Documents, with regards to acceptance or rejection of any proposals, and recommendation or award of the contract.

Note: The Statement of Affirmation Must be Notarized.

STATEMENT OF AFFIRMATION

The undersigned affirms that he/she is duly authorized to execute this waiver by the person(s) or business entity making the proposal.

Firm's Name: _____

Address: _____

Proposer's Name: _____

Position/Title: _____

Proposer's Signature: _____

Date: _____

Subscribed and sworn to me on this _____ day of _____ in the year _____

Notary Public

My Commission expires _____

T. ADDENDA

The undersigned acknowledges responsibility for all addenda issued prior to closing date. No addenda will be issued less than 48 hours prior to the solicitation submission deadline.

No. _____ No. _____ No. _____

Date _____ Date _____ Date _____

U. CERTIFICATION OF PROPOSAL

The undersigned affirms that they are duly authorized to execute this contract, that this proposal has not been prepared in collusion with any other Contractor, and that the contents of this proposal have not been communicated to any other Contractor prior to the official opening.

Signed By: _____ Title: _____

Typed Name: _____

Company Name: _____

Mailing Address: _____
P.O. Box or Street City State Zip

Employer Identification Number: _____

CORPORATE SEAL IF SUBMITTED BY A CORPORATION
END OF RFP NO. CIP 26-533

By signing below, Brazos County agrees that this RFP CIP 26-533 will be awarded to the respondent whose name appears above and both parties agree to the terms and conditions contained herein.

By: Brazos County Commissioner's Court _____

Date: _____

Attest: Brazos County Clerk _____

ALPR (Flock) camera scale

Ivan Svrček, 2500 Westwood Main Dr. Bryan, county Precinct #2.

979-218-2691 isvrcek@gmail.com

I would like to talk to you again about the ALPR cameras that are continuing to expand in our community and the United States as a whole.

That "United States as a whole" aspect is what I want to touch on today.

Now, when one is talking about adding a few cameras here and a few cameras there, we naturally think of them as a small system. A couple of points on the road that let our local law enforcement keep tabs on some movements in our county. That isn't what's really useful though, what's really useful is a big network.

I think a good way to understand our system is to look at our network logs and what they say. Now, I don't have any from the county at the moment but I do have some datasets from the Bryan Police Department. So, let's consider the first 2 weeks of April this year for the City of Bryan.

Between the 1st and 15th of April Bryan PD searched their camera data 337 times.

Of course, Bryan PD shares data with the county, which searched 64 times, and also College Station, which searched 275 times.

But what about any others? Is anyone else searching that data?

Yes, most definitely. In that same 2 weeks there were another 198,213 recorded searches from 409 different entities.

As you might think, a large number of those searches were from various Texas counties and city police departments but there are definitely some oddballs as well. Searches from Oklahoma, Ohio, the Union Pacific Railroad, UT Dallas and even Baylor Scott and White.

Now you have to ask yourself. Do I trust all 409 organizations that searched those records? Do I even know who can access this information?

We are building a big map with locations and pictures of all our citizens as they drive around the community. Then we are asking them to trust that this map will never be used against them even though they don't know who can read it or even exactly what it says.

I therefore ask you as my elected officials. Please, reconsider this path of massive surveillance that we are going down and reject large ALPR networks.

Thank you for your time.

Bryan PD Flock Search Audit	
2026/4/11 to 2026/4/15	
198889	Total Searches
275	CS PD searches
337	Bryan PD searches
64	Brazos SO searches
198213	Others
456	Total Organizations
453	Non BPD, CSPD, BRAZOS SO
Queries	Organization
35108	Houston TX PD
26798	Dallas TX PD
18310	Texas Department of Public Safety
9306	Harris County TX SO
4059	Fort Worth TX PD
3826	Grand Prairie TX PD
3268	Montgomery County TX SO
2757	Pasadena TX PD
2342	Garland TX PD
2267	Plano TX PD
2233	Harris County Const TX Pct 4
2053	Mesquite TX PD
1964	Arlington TX PD
1902	Lubbock TX PD
1795	League City TX PD
1776	Beaumont TX PD
1726	Richardson TX PD
1647	Carrollton TX PD
1599	Grapevine TX PD
1575	Farmers Branch TX PD
1526	Addison TX PD
1435	Sugar Land TX PD
1298	Bellaire TX PD
1291	San Antonio TX PD
1173	Baytown TX PD
1166	Fort Bend County TX SO
1153	Chambers County TX SO
1100	Odessa TX PD
1096	Pearland TX PD
1071	Brazoria County TX SO
1005	Midland TX PD
998	Tarrant County TX SO
989	Friendswood TX PD
965	McKinney TX PD
938	TX - Liberty County SO
921	Collin County TX SO
921	Webster TX PD
885	Denton County TX SO
838	Killeen TX PD
827	Irving TX PD
797	Amarillo TX PD
796	Harris County Const TX Pct 3
789	Montgomery County Constable, Precinct 4 (TX)
770	Round Rock TX PD
760	Reeves CO TX SO
759	Little Elm TX PD

758	Conroe TX PD
724	Harris County Const TX Pct 1
710	Lubbock County TX SO
698	Wichita Falls TX PD
677	Houston Metro Transit Authority (TX)
666	Humble TX PD
661	Harris County Const TX Pct 5
651	Frisco TX PD
633	Texas Department of Criminal Justice
629	Galveston County TX SO
603	Mansfield TX PD
597	Sealy TX PD
596	Austin County TX SO
591	Katy TX PD
566	North Richland Hills TX PD
559	Bexar County TX SO
516	Forney TX PD
513	Kaufman County TX SO
512	Texas City TX PD
510	Alvin TX PD
494	Rusk CO TX SO
489	Allen TX PD
466	Kingsville TX PD
440	Seabrook TX PD
439	El Paso TX PD
439	Lancaster TX PD
425	Canton TX PD
423	Gun Barrel TX PD
419	Eules TX PD
418	Temple TX PD
406	Ector County TX SO
405	Jersey Village TX PD
394	Kyle TX PD
386	Harris County Const TX Pct 2
364	Celina TX PD
361	Haltom City TX PD
361	Johnson County TX SO
360	Cedar Park TX PD
357	Splendora TX PD
353	Cooke County TX SO
351	Hidalgo County TX SO
349	Red Oak PD TX
337	Bryan TX PD
335	Keller TX PD
328	Burleson TX PD
328	Dickinson TX PD
327	Midland County TX SO
319	Waxahachie TX PD
317	Hopkins County TX SO
311	Hood Co. TX SO
311	Hurst TX PD
309	Duncanville TX PD
294	Fulshear TX PD
293	Waller County TX SO
282	Abilene TX PD
277	Galveston TX PD
275	College Station TX PD
275	Harrison County TX SO
274	Anthony TX PD

269	Seguin TX PD
265	Canadian County OK SO
257	La Marque TX PD
257	Stafford TX PD
256	Kaufman County Constable PCT 2
255	Boerne TX PD
254	Randall County TX SO
246	Cedar Hill TX PD
246	Rowlett PD TX
235	Smith County TX SO
234	Denton TX PD
233	Bastrop County TX SO
228	Texas Financial Crimes Intelligence Center
226	Cleburne TX PD
226	Horizon TX PD
225	Leander TX PD
224	Fort Bend County TX District Attorney's Office
222	Anna TX PD
221	Mont Belvieu TX PD
219	Grayson County TX SO
212	Tyler TX PD
210	Deer Park TX PD
205	Moore County TX SO
202	The Colony TX PD
200	Balch Springs TX PD
198	Sherman TX PD
196	Hunt County TX SO
193	TX - Nederland PD
189	Polk County TX SO
186	Bedford TX PD
183	DeSoto TX PD
180	DFW Airport PD TX
177	Livingston TX PD
173	Lake Jackson TX PD
172	Wylie TX PD
166	Hays County TX SO
165	Miami Township OH PD (Clermont)
163	Leon County District Attorney - TX
162	TX - Eastland County SO
160	Burnet County TX SO
157	Highland Park TX PD
154	Shenandoah TX PD
152	Jasper TX PD
152	Watauga TX PD
151	New Braunfels TX PD
144	Elm Ridge TX PD
137	Missouri City TX PD
137	Sunnyvale TX PD
136	White Settlement TX PD
134	Edinburg TX PD
133	Elgin TX PD
133	Pflugerville TX PD
133	TX - City of Orange
125	Erath County TX SO
125	Laredo TX PD
123	Falfurrias TX PD
121	Carson County TX SO
121	University of TX (UTA)- Arlington PD
120	Lamar County TX SO

120	Richland Hills TX PD
119	Coppell TX PD
117	Regional Vehicle Burglary Suppression Taskforce TX
116	Hitchcock TX PD
116	Rockwall County TX SO
114	Oak Point TX PD
113	Colleyville PD TX
112	Marble Falls TX PD
112	San Angelo TX PD
110	Aubrey TX PD
109	Snyder TX PD
108	Montgomery TX PD
108	Sterling County TX SO
106	Texarkana TX PD
105	Manor TX PD
104	Memorial Villages TX PD
104	Montgomery County Constable, Precinct 3 (TX)
103	Dumas TX PD
103	Lewisville TX PD
103	Prosper TX PD
101	River Oaks TX PD
96	Wilson County TX SO
92	Cypress Fairbanks ISD (TX) PD
90	TX - Commerce PD
89	Wharton PD TX
88	Montgomery County Constable, Precinct 5 (TX)
85	Guadalupe County TX SO
84	Bastrop TX PD
84	Cass County TX SO
83	Richmond TX PD
79	Potter County TX SO
79	TX - Seymour PD
77	Angleton PD TX
76	Cibolo TX PD
76	Hewitt TX PD
74	Tomball TX PD
74	Trophy Club TX PD
74	TX - Trinity County SO
73	Marshall TX PD
73	Marshall TX PD
73	Rockwall TX PD
72	Lakeside City TX
71	Ellis County TX SO
71	Kemah TX PD
69	Milam County TX SO
68	Corsicana TX PD
68	Paris TX PD
67	Granbury TX PD
67	Midlothian TX PD
67	Texas Medical Center PD
66	Roanoke TX PD
65	Bosque County TX SO
65	Reagan County TX SO
64	Brazos County TX SO
64	Melissa TX PD
63	Lumberton TX PD
63	Union Pacific Railroad PD
62	Fannin County TX SO
62	Hondo TX PD

62	Mexia TX PD
61	Hardin County SO TX
61	Liberty Hill TX PD
58	Hutchins TX PD
58	Kendall County TX SO
58	Rosenberg TX PD
54	Lufkin TX PD
52	Converse TX PD
50	Galena Park ISD TX PD
50	Huffman ISD TX PD
50	Saginaw TX PD
49	Mineola TX PD
49	Robstown TX PD
49	TX - Robinson PD
48	Lake Worth TX PD
48	TX Alcoholic Beverage Commission (TABC)
47	Hutto TX PD
46	Denison TX PD
45	Gray County TX SO
44	Van Alstyne TX PD
43	Angelina County TX SO
43	Cameron CO TX SO
43	Hickory Creek TX PD
43	Montague County TX SO
43	Winkler County TX SO
42	Holland TX PD
42	Seagoville TX PD
42	University of Texas at Dallas TX PD
41	Crandall TX PD
41	Highland Village TX
41	Taylor County TX SO
40	Martin County TX SO
40	West Tawakoni TX PD
39	Manvel TX PD
38	Azle TX PD
37	Bellville TX PD
37	Mount Vernon TX PD
37	Terrell TX PD
37	TX - Clute PD
36	Eagle Pass TX PD
36	Henderson TX PD
36	Southmayd TX PD
36	TX - Bellmead PD
35	Pampa TX PD
34	Schertz TX PD
34	Spring Branch TX ISD PD
34	TX - Vidor PD
34	University of Texas Permian Basin PD
31	1st Judicial District, District Attorney's Office TX
31	University of North Texas at Denton PD (TX)
30	Iowa Colony TX PD
30	La Porte TX PD
28	Northlake TX PD
28	Palestine TX PD
28	Sachse TX PD
27	Clay County TX SO
27	Monahans TX PD
27	Pharr TX PD
25	Live Oak TX PD

25	TX - Nolanville PD
24	Brownsville TX PD
24	Crowley TX PD
24	University of Texas at Tyler PD
23	Decatur TX PD
23	Houston Arson Bureau TX
23	Jack County TX SO
23	Krum TX PD
23	Ovilla TX PD
22	East Texas Auto Theft Task Force
22	Lago Vista TX PD
20	Aldine ISD PD TX
20	Dallas Area Rapid Transit PD TX
20	Fort Bend County Const TX Pct 1
20	La Vernia TX PD
20	Lindale TX PD
20	UT Southwestern Medical Center TX
20	Wallis TX PD
19	Baylor Scott & White PD (TX)
18	Belton TX PD
18	Castle Hills TX PD
18	Corinth TX PD
18	University of Texas at Houston PD
17	Cockrell Hill TX PD
17	Crowell TX PD
16	Buda TX PD
16	Sulphur Springs TX PD
15	Bulverde TX PD
15	Cactus TX PD
15	Castroville TX PD
15	Diboll TX PD
15	Paló Pinto County TX SO
15	TX - Bullard PD
15	TX - Hallettsville PD
14	Alvarado TX PD
14	Canyon TX PD
14	Glasscock County TX SO
14	South Houston TX PD
14	Spring Valley Village TX PD
13	Heath TX DPS
13	Kaufman TX PD
13	Lee County TX SO
13	Port Arthur TX PD
13	Port Neches PD (TX)
13	Sour Lake TX PD
12	Alvin ISD TX PD
12	Bee Cave TX PD
11	Rains County TX SO
11	Rockport TX PD
11	Thrall City PD TX
11	TX - Wichita Falls Independent School District
10	47th District Attorney's Office TX
10	Aransas Pass TX PD
10	Athens TX PD
10	Cumby TX PD
10	Franklin County TX SO
10	Lakeway TX PD
10	Murphy TX PD
10	Nash TX PD

10	TX - Jefferson County SO
9	Bay City TX PD
9	Fort Bend County Const TX Pct 4
9	Harris County Fire Marshal TX
9	North TX Anti-Gang Center (TAG)
9	Princeton TX PD
9	Sansom Park TX PD
9	TX - Eastland PD
9	TX - Mustang Ridge PD
9	University Park TX PD
9	Ward County TX SO
8	Argyle TX PD
8	City of Oak Ridge North TX PD
8	Fort Stockton TX PD
8	TX - Mount Enterprise PD
8	Waller TX PD
8	Willis TX PD
7	Dalworthington Gardens TX PD
7	Midland County Hospital District PD TX
6	Fort Bend County TX Environmental Health
6	Lavon TX PD
6	Magnolia PD TX
6	Robertson County TX SO
6	Stephenville TX PD
6	Universal City TX PD
6	University of Houston Downtown TX PD
5	Bartonville TX PD
5	Borger TX PD
5	Caldwell CO TX SO
5	Caldwell County TX Constable's Pct 2
5	Crane County SO TX
5	El Campo TX PD
5	Ingleside TX PD
5	Onalaska TX PD
5	Sunset Valley TX PD
5	TX - Baylor County SO
5	TX - Wink PD
5	Tye TX PD
4	Donley County TX SO
4	Ector County Environmental Enforcement (TX)
4	Kleberg TX County Attorney's Task Force
4	TX - San Saba County SO
4	Venus TX PD
3	Concho County TX SO
3	Jacinto City TX PD
3	Methodist Health System PD (TX)
3	Red River TX SO
3	Rice University TX PD
3	TX - Liberty PD
3	TX - Palmer PD
3	Westworth Village TX PD
3	Winnsboro TX PD
2	Queen City TX PD
2	Reno TX PD
2	Roman Forest TX PD
2	San Benito TX PD
2	South Plains Auto Theft Task Force TX
2	Tarleton State University TX PD
2	TX - Groves PD

2	TX - Sinton PD
2	Wheeler County TX SO
1	Boyd TX PD
1	Greenwood Independent School District TX
1	Hartley County TX SO
1	Mabank TX PD
1	Meadows Place TX PD
1	Midwestern State University TX PD
1	Mineral Wells TX PD
1	Pantego TX PD
1	TX - City of Town of Pecos
1	TX - Young County SO
1	Tyler TX ISD PD



**BRAZOS COUNTY
BRYAN, TEXAS**

DEPARTMENT:

NUMBER:

DATE OF COURT MEETING: 6/23/2026

ITEM:

- Presentation and discussion regarding recognition of the Brazos County Historical Commission as a recipient of the 2025 Distinguished Service Award from the Texas Historical Commission.

TO: Commissioners Court

DATE: 06/06/2026

FISCAL IMPACT: False

BUDGETED: False

DOLLAR AMOUNT: \$0.00

ATTACHMENTS:

File Name

Description

Type

[2025 Distinguished service award Historical Commission.pdf](#)

2025 Distinguished Service Award Historical Commission

Cover Memo

TEXAS HISTORICAL COMMISSION

PRESENTS THIS

2025

DISTINGUISHED SERVICE AWARD

TO

BRAZOS COUNTY HISTORICAL COMMISSION

IN RECOGNITION OF ITS ACTIVE
AND WELL-BALANCED PRESERVATION PROGRAM

EXECUTIVE DIRECTOR

May 26, 2026
DATE



**TEXAS
HISTORICAL
COMMISSION**
REAL PLACES TELLING REAL STORIES



**BRAZOS COUNTY
BRYAN, TEXAS**

DEPARTMENT: Brazos County Office of the Sheriff-Detention Ctr. NUMBER:

DATE OF COURT MEETING: 6/23/2026

ITEM: Approval for acceptance of donated or unclaimed property items left by inmates leaving the Brazos County Detention Center for the months of March and April 2026.

TO: Commissioners Court

FROM: Chief Kevin Stuart, CJM

DATE: 06/10/2026

FISCAL IMPACT: False

BUDGETED: False

DOLLAR AMOUNT: \$0.00

NOTES/EXCEPTIONS: Clothing, Jewelry, Electronics, other items left by inmates that have left the BCDC in the month of March and April 2026 - this is the donation form needing approval along with the backup itemized items.

ATTACHMENTS:

File Name

Description

Type

[Property Donation form for signature-March 2026.pdf](#)

Donation form for approval signature-March

Cover Memo

[Property Donation form for signature-April 2026.pdf](#)

Donation form for approval signature-April 2026

Cover Memo



**BRAZOS COUNTY, TEXAS
ACCEPTANCE OF DONATED/AWARDED PROPERTY
DONATION OF COUNTY PROPERTY**

Date: 6/10/2026

Acceptance of Donated/Awarded Property
(Awarded property requires signed court documentation)

Donation of County Property

Acceptance of Donated Inmate Property
(Requires signed inmate documentation - NO VALUE ASSESSED)

Item Description: _____

Please provide all information requested below as applicable to the property being accepted or donated. Forms containing any blank fields will be returned for completion.

Make: _____ Model: _____ Year: _____ SN/VIN #: _____

Functional Non-Functional. Explain if Non-Functional _____

Additional Description/Information: Clothing, Jewelry, Electronics, Other Misc Items left by inmates that have left the Brazos County Detention Center in the month of March 2026

Estimated Value: _____

Check box if the donated property is in possession of the County department.

Acceptance of Donated Property	Donation of County Property
Check the appropriate account based on estimated value of property being accepted:	Check the appropriate entity property being donated to:
<input type="checkbox"/> 61235000 (Donation - Other)*	Government Entity: <u>Brazos County Sheriff Of</u>
<input checked="" type="checkbox"/> 60010000 (Minor Property - \$1 - \$9999)	Organization Name <input checked="" type="checkbox"/>
<input type="checkbox"/> 80010000 (Capital Property - Over \$10,000)	Other (Due to Statutory requirements prior approval is required by Purchasing: _____)
For Budget use only	Organization Name _____

*Donation - Other account 61235000 is to be used ONLY for cash/check funds donated to Brazos County.

I certify that the above-mentioned item has been donated or awarded to Brazos County. This item has been received in good faith and upon approval by Commissioner's Court will become a part of the General Fixed Asset Account of Brazos County. The determination to accept or reject the donation will be made at the sole discretion of Commissioners Court based upon such things as usefulness, projected operating, maintenance, and insurance costs.

Requesting Department: Booking Division Brazos County Sheriff Office Department Name Logan Medeiros Authorized Signature

Organization Receiving Donated Property: Logan Medeiros Authorized Signature

Approved by Commissioners Court on this 23 day of June 2026.

Commissioners Court Approval

<i>For Treasurer's Use Only</i>	
Division:	<u>Booking</u>
Account:	<u>46023000</u>



**BRAZOS COUNTY, TEXAS
ACCEPTANCE OF DONATED/AWARDED PROPERTY
DONATION OF COUNTY PROPERTY**

Date: 6/10/2026

- Acceptance of Donated/Awarded Property
(Awarded property requires signed court documentation)
- Donation of County Property
- Acceptance of Donated Inmate Property
(Requires signed inmate documentation - NO VALUE ASSESSED)

Item Description: _____

Please provide all information requested below as applicable to the property being accepted or donated. Forms containing any blank fields will be returned for completion.

Make: _____ Model: _____ Year: _____ SN/VIN #: _____

Functional Non-Functional. Explain if Non-Functional _____

Additional Description/Information: Clothing, Jewelry, Electronics, Other Misc Items left by inmates that have left the Brazos County Detention Center in the month of April 2026

Estimated Value: _____ Check box if the donated property is in possession of the County department.

Acceptance of Donated Property	Donation of County Property
Check the appropriate account based on estimated value of property being accepted:	Check the appropriate entity property being donated to:
<input type="checkbox"/> 61235000 (Donation - Other)*	Government Entity: <u>Brazos County Sheriff Of</u>
<input checked="" type="checkbox"/> 60010000 (Minor Property - \$1 - \$9999)	Organization Name
<input type="checkbox"/> 80010000 (Capital Property - Over \$10,000)	Other (Due to Statutory requirements prior approval is required by Purchasing: _____)
For Budget use only	Organization Name

*Donation - Other account 61235000 is to be used ONLY for cash/check funds donated to Brazos County.

I certify that the above-mentioned item has been donated or awarded to Brazos County. This item has been received in good faith and upon approval by Commissioner's Court will become a part of the General Fixed Asset Account of Brazos County. The determination to accept or reject the donation will be made at the sole discretion of Commissioners Court based upon such things as usefulness, projected operating, maintenance, and insurance costs.

Requesting Department: Booking Brazos County Sheriff Office Logan Medeiros
Division Department Name Authorized Signature

Organization Receiving Donated Property: Logan Medeiros
Authorized Signature

Approved by Commissioners Court on this 23 day of June 2026.

Commissioners Court Approval

For Treasurer's Use Only	
Division:	<u>Booking</u>
Account:	<u>46023000</u>



**BRAZOS COUNTY
BRYAN, TEXAS**

DEPARTMENT:

NUMBER:

DATE OF COURT MEETING: 6/23/2026

ITEM: Approval of the Treasurer's Report for April 2026.

TO: Commissioners Court

DATE: 06/11/2026

FISCAL IMPACT: False

BUDGETED: False

DOLLAR AMOUNT: \$0.00

ACTION REQUESTED OR
ALTERNATIVES: Approval

ATTACHMENTS:

<u>File Name</u>	<u>Description</u>	<u>Type</u>
Treasurer s Report Approval April 2026.pdf	Treasurer Report Approval	Backup Material
Treasurer s Monthly Report April 2026.pdf	Treasurer's Report April 2026	Backup Material

The State of Texas, County of **BRAZOS**

We, the undersigned, as County Commissioners within and for Brazos County, and Duane Peters, County Judge of Brazos County, constituting the entire Commissioners' Court of Brazos County, during a regular meeting of said Court have examined the foregoing report and have caused an order to be entered upon the Minutes of the Commissioners' Court of Brazos County approving said Report as presented and submitted as true and correct by Cristian Villarreal, Treasurer of Brazos County, as provided for in the Revised Statutes of the State of Texas. (*Texas Local Government Code, 114.026*)

Witness my hand this 23 day of June A.D. 2026

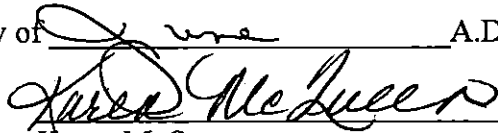

Karen McQueen
County Clerk, County of BRAZOS, State of Texas

Examined and approved in open Commissioners' Court this 23 day of

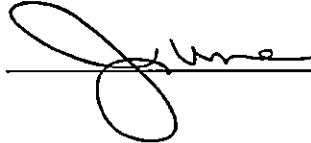

2026.



Duane Peters, County Judge

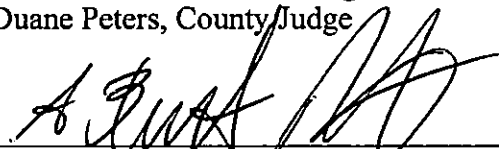

Bentley Nettles, Commissioner Precinct #1



Chuck Konderla, Commissioner Precinct #2



Fred Brown, Commissioner Precinct #3



Wanda J. Watson, Commissioner Precinct #4

Treasurer's Report for the **MONTH APRIL 2026**

APRIL 2026 TREASURER'S REPORT

FUND NUMBER & NAME	CASH BALANCE 3/31/2026	INCOMING	INVESTED INTEREST	SUB-TOTAL	DISBURSED	CASH BALANCE 4/30/2026	INVESTED	CK.ACCT.BAL. 4/30/2026
0100 - GENERAL FUND	189,626,965.20	13,103,030.68	530,208.67	203,260,204.55	12,029,451.11	191,230,753.44	155,542,507.12	35,688,246.32
1100 - HOTEL OCCUPANCY TAX	8,070,933.43	412,315.56		8,483,248.99	39,634.63	8,443,614.36		8,443,614.36
1200 - STATE LATERAL ROAD	169,854.31	607.62		170,461.93	0.00	170,461.93		170,461.93
1300 - UNCLAIMED FUNDS	619,098.26	14,178.84		633,277.10	3,516.95	629,760.15		629,760.15
1500 - LAW LIBRARY	259,912.72	11,482.91		271,395.63	6,654.00	264,741.63		264,741.63
1800 - LEOSE FUND	130,482.05	0.00		130,482.05	0.00	130,482.05		130,482.05
2000 - COUNTY CLERK MGMT.FUND	1,478,162.10	34,395.98		1,512,558.08	15,904.40	1,496,653.68		1,496,653.68
2001 - COUNTY CLERK ARCHIVAL FUND	1,755,830.99	33,621.12		1,789,452.11	0.00	1,789,452.11		1,789,452.11
2200 - COURTHOUSE SECURITY FUND	277,601.84	11,701.78		289,303.62	1,478.23	287,825.39		287,825.39
2201 - JUSTICE COURT SECURITY FUND	305,340.95	1,980.15		307,321.10	0.00	307,321.10		307,321.10
2300 - DISTRICT CLERK MANAGEMENT FUND	946,232.46	15,876.73		962,109.19	2,700.06	959,409.13		959,409.13
2301 - DISTRICT CLERK ARCHIVAL FUND	0.00	0.00		0.00	0.00	0.00		0.00
2400 - JUSTICE @ PEACE - TECHNOLOGY FUND	112,740.27	3,238.08		115,978.35	0.00	115,978.35		115,978.35
2401 - CO.& DIST.COURT TECHNOLOGY FUND	157,739.70	1,209.47		158,949.17	0.00	158,949.17		158,949.17
2500 - SPECIAL FORFEITURE FUND	89,034.10	1,466.68		90,500.78	0.00	90,500.78		90,500.78
2600 - D/A HOT CHECK COLLECT FEES	6,049.32	21.64		6,070.96	0.00	6,070.96		6,070.96
2700 - BAIL BOND BOARD FEES	125,383.39	948.53		126,331.92	0.00	126,331.92		126,331.92
2900 - VIT INTEREST FUND	481,177.25	2,085.41		483,262.66	0.00	483,262.66		483,262.66
3000 - COUNTY GRANTS	(341,148.91)	173,812.51		(167,336.40)	452,495.59	(619,831.99)		(619,831.99)
3100 - AMERICAN RESCUE PLAN ACT	14,346,000.64	0.00		14,346,000.64	2,062,317.57	12,283,683.07		12,283,683.07
3200 - SB 22 2023 RURAL	868,597.90	3,107.23		871,705.13	38,216.11	833,489.02		833,489.02
3400 - D/A CRIME FUND	130,886.17	468.22		131,354.39	3,347.88	128,006.51		128,006.51
3500 - PRIMARY ELECTION SERVICES	10,699.40	38.27		10,737.67	0.00	10,737.67		10,737.67
3901 - BC HOUSING FINANCE CORP	627,267.70	2,243.92		629,511.62	0.00	629,511.62		629,511.62
4320 - CO 2020	221,091.75	790.91		221,882.66	2,245.53	219,637.13		219,637.13
4323 - ON SYSTEM ROAD BOND-TXDOT	9,769,912.45	1,979.06	28,636.02	9,800,527.53	37,848.94	9,762,678.59	9,245,320.68	517,357.91
43231 - OFF SYSTEM ROAD BOND	2,765,289.20	2,592.58	6,339.94	2,774,221.72	871,396.33	1,902,825.39	2,046,895.86	(144,070.47)
43232 - 2023 CERTIFICATES OF OBLIGATIONS	66,035,554.65	377.75	21,531.21	66,057,463.61	5,047,596.48	61,009,867.13	6,951,489.39	54,058,377.74
4500 - GEN.PERMANENT IMPV.	10,904,269.21	0.00		10,904,269.21	1,445,838.13	9,458,431.08		9,458,431.08
5000 - HEALTH & LIFE INSURANCE	13,416,813.70	2,109,598.84		15,526,412.54	2,502,220.02	13,024,192.52		13,024,192.52
5800 - COUNTY ATTORNEY OPERATING FUND	65,354.85	0.00		65,354.85	0.00	65,354.85		65,354.85
6000 - PAYROLL	1,856,674.73	6,981,117.08		8,837,791.81	7,590,198.00	1,247,593.81		1,247,593.81
9100 - HEALTH DEPARTMENT	4,110,358.26	204,688.13		4,315,046.39	359,226.69	3,955,819.70		3,955,819.70
9300 - REGIONAL MOBILITY AUTHORITY	44,236.98	158.25		44,395.23	0.00	44,395.23		44,395.23
9700 - COMMUNITY SUPERVISION	1,321,770.18	195,527.89		1,517,298.07	387,287.80	1,130,010.27		1,130,010.27
TITLE OF ACCTS: IN POOL	330,766,167.20	23,324,661.82	586,715.84	354,677,544.86	32,899,574.45	321,777,970.41	173,786,213.05	147,991,757.36
1600 - LOCAL PROVIDER PARTICIPATION	22,713,965.41	9,782,403.20		32,496,368.61	779,926.54	31,716,442.07		31,716,442.07
4100 - GEN.OBLIG.DEBT SVC.	15,762,212.66	120,647.06	13,165.02	15,896,024.74		15,896,024.74	4,250,409.83	11,645,614.91
TOTAL	369,242,345.27	33,227,712.08	599,880.86	403,069,938.21	33,679,500.99	369,390,437.22	178,036,622.88	191,353,814.34

This report is submitted as true and correct to Commissioners Court by Cristian T. Villarreal, Brazos County Treasurer, on June 23, 2026.



**BRAZOS COUNTY
BRYAN, TEXAS**

DEPARTMENT:

NUMBER:

DATE OF COURT MEETING:

6/23/2026

ITEM:

Tax Refund Applications for the following:

Overpayments

- a. Triad Financial Services - \$1,480.15

TO:

Commissioners Court

DATE:

06/15/2026

FISCAL IMPACT:

False

BUDGETED:

False

DOLLAR AMOUNT:

\$0.00

Overpayments or Erroneous Payments (Tax Code Section 31.11)

If a taxpayer applies for a refund, the collector must determine whether the payment was erroneous or excessive. If the collector determines the payment was erroneous or excessive and the auditor agrees, the collector refunds the payment from available current tax collections or from funds appropriated for making refunds.

NOTES/EXCEPTIONS:

Governing Body Approval (Tax Code Section 31.11(a)(1) and (a)(2))

Certain refunds require approval from the taxing unit's governing body. If a collector collects taxes for a single taxing unit, refunds exceeding \$500 must receive approval from the taxing unit's governing body. If a collector collects taxes for more than one taxing unit, refunds exceeding \$2,500 must receive approval from the taxing unit's governing body.

As general practice the County Auditor has chosen to present all tax refunds to the Commissioner's Court , even those that do not require approval from the Court.



**BRAZOS COUNTY
BRYAN, TEXAS**

DEPARTMENT: Budget Office NUMBER:
DATE OF COURT MEETING: 6/23/2026
ITEM: FY 25/26 Budget Amendments 19.01 - 19.10.
TO: Commissioners Court
FROM: Nina Payne
DATE: 06/15/2026
FISCAL IMPACT: False
BUDGETED: False
DOLLAR AMOUNT: \$0.00
ACTION REQUESTED OR ALTERNATIVES: Request approval.

ATTACHMENTS:

<u>File Name</u>	<u>Description</u>	<u>Type</u>
19_Coversheet.pdf	FY 26 - 19 Coversheet	Cover Memo
19.01 - 19.10.pdf	FY 26 Budget Amendments 19.01 - 19.10	Budget Amendment

BRAZOS COUNTY, TEXAS

BUDGET AMENDMENT(S) FOR THE 2025-2026 BUDGET YEAR

NO. 25/26 19.01 – 19.10

On this the 23rd day of June 2026 at a regular meeting of the Commissioners' Court, the following members were present:

- A. Duane Peters, County Judge, Presiding
- B. Bentley Nettles, Commissioner, Precinct 1
- C. Chuck Konderla, Commissioner, Precinct 2
- D. Fred Brown, Commissioner, Precinct 3
- E. Wanda Watson, Commissioner, Precinct 4
- F. Karen McQueen, County Clerk

The following proceedings were held:

THAT WHEREAS, on the 23rd day of June 2026 the Court heard and approved a budget amendment(s) for the 2025-2026 budget year for Brazos County, Texas; and

WHEREAS, expenditure is necessary due to the necessity to meet unusual and unforeseen conditions which could not be reasonably included in the original budget adopted 9 September 2025, the following amendment(s) to the original budget are hereby authorized, as described on the attached page(s).

ADOPTED AND APPROVED this the 23rd day of June 2026.

THE COMMISSIONERS COURT OF BRAZOS COUNTY, TEXAS.

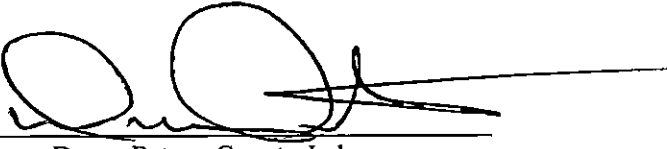
By: 
Duane Peters, County Judge

Original: County Clerk's Office and
Attached to the original budget



BRAZOS COUNTY
REQUEST FOR BUDGET AMENDMENT

Budget
Amendment
Number *

Budget Amendment Number

19.01

Agenda Date

6/23/2026

Fiscal Year

October 1 - September 30 2026

Requesting Department

BUDGET OFFICE

Requestors Name

Nina Payne

DECREASE EXPENDITURE(S):

1000 General Fund

From: Fund Number

DECREASE EXPENDITURE(S):

11001500 Contingency

From: Division Name

DECREASE EXPENDITURE(S):

61130000 Contingency

From: Account Number

From: Amount

\$

10,000.00

AMOUNT OF DECREASE

Total

\$ 10,000.00

TOTAL AMOUNT OF DECREASE

INCREASE EXPENDITURE(S):

1000 General Fund

To: Fund Number

INCREASE EXPENDITURE(S):

34200100 Forensic Services - Ar

To: Division Name

INCREASE EXPENDITURE(S):

61880000 Utilities Expenditure

To: Account Number

To: Amount

\$

10,000.00

AMOUNT OF INCREASE

Total

\$ 10,000.00

TOTAL AMOUNT OF INCREASE

TO EXPLANATION AND SIGNATURE

Explanation

Explanation to reclassify budget to proper accounts:

Reallocation of funds to the appropriate account to cover utilities at the Medial Examiner's Building for the remainder of FY 2026.

File and Documentation

File Upload

Upload

Signature

Initiator

Memo Payne

Department (?)

BUDGET OFFICE

Signature

Elected Official/Dept Head

Memo Payne

Comments

Elected Official/Dept Head Comments

Signature

Budget Officer Signature

Spencer A Mays

Budget Officer Comments

CC Approval Oracle Posted

Sign

Completion Date

Date will be captured on form submission

Comments

Commissioners Court Decision Comments



BRAZOS COUNTY
REQUEST FOR BUDGET AMENDMENT

**Budget
Amendment
Number ***

Budget Amendment Number

19.02

Agenda Date

6/23/2026

Fiscal Year

October 1 - September 30 2026

Requesting Department

BUDGET OFFICE

Requestors Name

Nina Payne

DECREASE EXPENDITURE(S):

1000 General Fund

From: Fund Number

DECREASE EXPENDITURE(S):

11001500 Contingency

From: Division Name

DECREASE EXPENDITURE(S):

61130000 Contingency

From: Account Number

From: Amount

\$ 10,000.00

AMOUNT OF DECREASE

Total

\$ 10,000.00

TOTAL AMOUNT OF DECREASE

INCREASE EXPENDITURE(S):

1000 General Fund

To: Fund Number

INCREASE EXPENDITURE(S):

22300100 472nd District Court -

To: Division Name

INCREASE EXPENDITURE(S):

61900000 Visiting Court Reporte

To: Account Number

To: Amount

\$ 10,000.00

AMOUNT OF INCREASE

Total

\$ 10,000.00

TOTAL AMOUNT OF INCREASE

TO EXPLANATION AND SIGNATURE

Explanation

Explanation to reclassify budget to proper accounts.

Reallocation of funds to the appropriate account to cover visiting court reporters for the remainder of FY 2026.

File and Documentation

File Upload

Upload
2026 Budget Amendment.pdf

364.92KB

Signature

Initiator

Nina Payne

Department (?)

BUDGET OFFICE

Signature

Elected Official/Dept Head

Nina Payne

Comments

Elected Official/Dept Head Comments

Signature

Budget Officer Signature

Spencer A. Mays

Budget Officer Comments

CC Approval Oracle Posted

Sign

Completion Date

Date will be captured on form submission

Comments

Commissioners Court Decision Comments



**472ND DISTRICT COURT
BRAZOS COUNTY, TEXAS**

Brazos County Courthouse
300 East 26th Street, Suite 2600 Bryan, Texas 77803
Telephone: (979) 361-2606

**G. Jerrell Wise
Judge Presiding**

**Kresta McCall - Court Coordinator
Angie Garcia - Administrative Secretary**

**Richard Mendez - Bailiff
Corina Lozano - Court Reporter**

June 5, 2026

I respectfully request additional funding in the amount of \$ 6,500.00 to cover the cost of a visiting court reporter while the County's court reporter is on approved leave.

Court proceedings must continue without interruption, and a qualified visiting court reporter is necessary to ensure hearings, trials, and other proceedings are properly recorded and conducted in accordance with state requirements.

Due to the limited availability of certified court reporters, the cost of securing temporary coverage exceeds the funds currently budgeted for this purpose.

The requested funding will allow the Court to maintain operations and avoid delays in the administration of justice during the employee's absence.

Thank you for your consideration of this request.

Sincerely,

A handwritten signature in black ink, appearing to read "G. Jerrell Wise".

**G. Jerrell Wise
Judge Presiding**

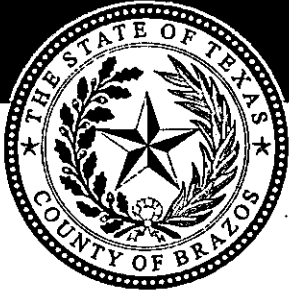

BRAZOS COUNTY
REQUEST FOR BUDGET AMENDMENT

Budget
Amendment
Number*

Budget Amendment Number

19.03

Agenda Date

6/23/2026

Fiscal Year

October 1 - September 30 2026

Requesting Department

BUDGET OFFICE

Requestors Name

Nina Payne

DECREASE EXPENDITURE(S):	DECREASE EXPENDITURE(S):	DECREASE EXPENDITURE(S):	From: Amount
1000 General Fund	11001500 Contingency	61130000 Contingency	\$ 827,746.00
From: Fund Number	From: Division Name	From: Account Number	AMOUNT OF DECREASE

DECREASE EXPENDITURE(S):	DECREASE EXPENDITURE(S):	DECREASE EXPENDITURE(S):	From: Amount
45000 Capital Improvement Fun	63110001 Commissioners' Court	61130000 Contingency	\$ 1,572,254.00
From: Fund Number	From: Division Name	From: Account Number	AMOUNT OF DECREASE

DECREASE EXPENDITURE(S):	DECREASE EXPENDITURE(S):	DECREASE EXPENDITURE(S):	From: Amount
45000 Capital Improvement Fun	63110001 Commissioners' Court	80205000 Computer - Network C	\$ 50,000.00
From: Fund Number	From: Division Name	From: Account Number	AMOUNT OF DECREASE

Total \$ 2,450,000.00
TOTAL AMOUNT OF DECREASE

INCREASE EXPENDITURE(S):	INCREASE EXPENDITURE(S):	INCREASE EXPENDITURE(S):	To: Amount
45000 Capital Improvement Fun	63110001 Commissioners' Court	80101000 Building Improvement	\$ 808,500.00
To: Fund Number	To: Division Name	To: Account Number	AMOUNT OF INCREASE

INCREASE EXPENDITURE(S):	INCREASE EXPENDITURE(S):	INCREASE EXPENDITURE(S):	To: Amount
45000 Capital Improvement Fun	63110001 Commissioners' Court	80440000 Land	\$ 1,641,500.00
To: Fund Number	To: Division Name	To: Account Number	AMOUNT OF INCREASE

Total

\$ 2,450,000.00

TOTAL AMOUNT OF INCREASE

TO EXPLANATION AND SIGNATURE

Explanation

Explanation to reclassify budget to proper accounts:

Reallocation of funds to the appropriate account to purchase the 108 San Jacinto Ln. property and for the environmental and structural review of property. Commissioner's Court approved the contract to purchase property on June 9, 2026.

File and Documentation

File Upload

Upload

Agenda 6.9.26 - 108 San Jacinto Contract Approval.pdf

9.6MB

Signature

Initiator

Mina Pugno

Department (?)

BUDGET OFFICE

Signature

Elected Official/Dept Head

Mina Pugno

Comments

Elected Official/Dept Head Comments

Signature

Budget Officer Signature

Spencer A. Maye

Budget Officer Comments

CC Approval Grade Posted

Sign

Completion Date

Date will be captured on form submission

Comments

Commissioners Court Decision Comments



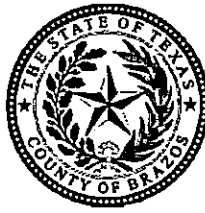

**BRAZOS COUNTY
BRYAN, TEXAS**

DEPARTMENT: Budget Office NUMBER:
DATE OF COURT MEETING: 6/9/2026
ITEM: Approval of Contract with Mesquite Properties Joint Venture for the purchase of real property in the amount of \$2,400,000.00.
TO: Commissioners Court
FROM: Nina Payne
DATE: 05/26/2026
FISCAL IMPACT: False
BUDGETED: False
DOLLAR AMOUNT: \$0.00
ACTION REQUESTED OR ALTERNATIVES: Request approval.

ATTACHMENTS:

<u>File Name</u>	<u>Description</u>	<u>Type</u>
108_San_Jacinto_Draft_Contract_v2r_(WWAG_Revised)_AGENDA_6.9.26.pdf	Commercial Contract - 108 San Jacinto Ln. Bryan	Backup Material



COMMERCIAL CONTRACT - IMPROVED PROPERTY

USE OF THIS FORM BY PERSONS WHO ARE NOT MEMBERS OF THE TEXAS ASSOCIATION OF REALTORS®, INC. IS NOT AUTHORIZED.
©Texas Association of REALTORS®, Inc. 2022

1. **PARTIES:** Seller agrees to sell and convey to Buyer the Property described in Paragraph 2. Buyer agrees to buy the Property from Seller for the sales price stated in Paragraph 3. The parties to this contract are:

Seller: Mesquite Properties Joint Venture

Address: 4279 SH 6 S, Suite 200, College Station, TX 77845

Phone: (979)220-1317 E-mail: josh@clarkisenhour.com

Mobile: _____ Fax or Other: _____

Buyer: Mike Gentry and/or Assigns

Address: 1515 Emerald Parkway , College Station, TX 77845

Phone: (979)694-7000 E-mail: mike.gentry@westwebblaw.com

Mobile: _____ Fax or Other: _____

2. PROPERTY:

A. "Property" means that real property situated in Brazos County, Texas at 108 San Jacinto Ln, Bryan TX 77803 (address) and that is legally described on the attached Exhibit N/A or as follows: SFA 9, BLOCK 34, LOT 7 (TR-218), ACRES 6.857

B. Seller will sell and convey the Property together with:

- (1) all buildings, improvements, and fixtures;
- (2) all rights, privileges, and appurtenances pertaining to the Property, including Seller's right, title, and interest in any minerals, utilities, adjacent streets, alleys, strips, gores, and rights-of-way;
- (3) Seller's interest in all leases, rents, and security deposits for all or part of the Property;
- (4) Seller's interest in all licenses and permits related to the Property;
- (5) Seller's interest in all third party warranties or guaranties, if transferable, relating to the Property or any fixtures;
- (6) Seller's interest in any trade names, if transferable, used in connection with the Property; and
- (7) all Seller's tangible personal property located on the Property that is used in connection with the Property's operations except: N/A

Any personal property not included in the sale must be removed by Seller prior to closing.

(Describe any exceptions, reservations, or restrictions in Paragraph 12 or an addendum.)

(If mineral rights are to be reserved an appropriate addendum should be attached.)

(If the Property is a condominium, attach Commercial Contract Condominium Addendum (TXR-1930) or (TXR-1946).)

3. **SALES PRICE:** At or before closing, Buyer will pay the following sales price for the Property:

A. Cash portion payable by Buyer at closing	\$	<u>2,400,000.00</u>
B. Sum of all financing described in Paragraph 4	\$	<u>TBD</u>
C. Sales price (sum of 3A and 3B)	\$	<u>2,400,000.00</u>

(TXR-1801) 07-08-22

Initialed for Identification by Seller _____, _____ and Buyer _____, _____

Page 1 of 15

4. FINANCING: Buyer will finance the portion of the sales price under Paragraph 3B as follows:

- A. **Third Party Financing:** One or more third party loans in the total amount of \$ TBD. This contract:
 - (1) is not contingent upon Buyer obtaining third party financing.
 - (2) is contingent upon Buyer obtaining third party financing in accordance with the attached Commercial Contract Financing Addendum (TXR-1931).
- B. **Assumption:** In accordance with the attached Commercial Contract Financing Addendum (TXR-1931), Buyer will assume the existing promissory note secured by the Property, which balance at closing will be \$ N/A.
- C. **Seller Financing:** Buyer will deliver a promissory note and deed of trust to Seller under the terms of the attached Commercial Contract Financing Addendum (TXR-1931) in the amount of \$ N/A.

5. EARNEST MONEY: 10 business

- A. Not later than 10 days after the effective date, Buyer must deposit \$ \$25,000.00 as earnest money with Lawyer's Title Company (title company) at 1450 Copperfield Pkwy College Station, TX 77845 (address) Lori Smith (closer). If Buyer fails to timely deposit the earnest money, Seller may terminate this contract or exercise any of Seller's other remedies under Paragraph 15 by providing written notice to Buyer before Buyer deposits the earnest money.
- B. Buyer will deposit an additional amount of \$ N/A with the title company to be made part of the earnest money on or before:
 - (i) N/A days after Buyer's right to terminate under Paragraph 7B expires; or
 - (ii) N/A
 Buyer will be in default if Buyer fails to deposit the additional amount required by this Paragraph 5B within 3 days after Seller notifies Buyer that Buyer has not timely deposited the additional amount.
- C. Buyer may instruct the title company to deposit the earnest money in an interest-bearing account at a federally insured financial institution and to credit any interest to Buyer.

6. TITLE POLICY, SURVEY, AND UCC SEARCH:

A. **Title Policy:**

- (1) Seller, at Seller's expense, will furnish Buyer an Owner's Policy of Title Insurance (the title policy) issued by any underwriter of the title company in the amount of the sales price, dated at or after closing, insuring Buyer against loss under the title policy, subject only to:
 - (a) those title exceptions permitted by this contract or as may be approved by Buyer in writing; and
 - (b) the standard printed exceptions contained in the promulgated form of title policy unless this contract provides otherwise.
- (2) The standard printed exception as to discrepancies, conflicts, or shortages in area and boundary lines, or any encroachments or protrusions, or any overlapping improvements:
 - (a) will not be amended or deleted from the title policy.
 - (b) will be amended to read "shortages in areas" at the expense of Buyer Seller.
- (3) Within 14 days after the effective date, Seller will furnish Buyer a commitment for title insurance (the commitment) including legible copies of recorded documents evidencing title exceptions. Seller authorizes the title company to deliver the commitment and related documents to Buyer at Buyer's address.

B. Survey: Within 30 days after the effective date:

- (1) Buyer will obtain a survey of the Property at Buyer's expense and deliver a copy of the survey to Seller. The survey must be made in accordance with the: (i) ALTA/NSPS Land Title Survey standards, or (ii) Texas Society of Professional Surveyors' standards for a Category 1A survey under the appropriate condition. Seller will reimburse Buyer _____ (insert amount) of the cost of the survey at closing, if closing occurs.
- (2) Seller, at Seller's expense, will furnish Buyer a survey of the Property dated after the effective date. The survey must be made in accordance with the: (i) ALTA/NSPS Land Title Survey standards, or (ii) Texas Society of Professional Surveyors' standards for a Category 1A survey under the appropriate condition.
- (3) Seller will deliver to Buyer and the title company a true and correct copy of Seller's most recent survey of the Property along with an affidavit required by the title company for approval of the existing survey. If the existing survey is not acceptable to the title company, Seller Buyer (updating party), will, at the updating party's expense, obtain a new or updated survey acceptable to the title company and deliver the acceptable survey to the other party and the title company within 30 days after the title company notifies the parties that the existing survey is not acceptable to the title company. The closing date will be extended daily up to 30 days if necessary for the updating party to deliver an acceptable survey within the time required. The other party will reimburse the updating party _____ (insert amount or percentage) of the cost of the new or updated survey at closing, if closing occurs.

C. UCC Search:

- (1) Within _____ days after the effective date, Seller, at Seller's expense, will furnish Buyer a Uniform Commercial Code (UCC) search prepared by a reporting service and dated after the effective date. The search must identify documents that are on file with the Texas Secretary of State and the county where the Property is located that relate to all personal property on the Property and show, as debtor, Seller and all other owners of the personal property in the last 5 years.
- (2) Buyer does not require Seller to furnish a UCC search.

D. Buyer's Objections to the Commitment, Survey, and UCC Search:

- (1) Within 14 days after Buyer receives the last of the commitment, copies of the documents evidencing the title exceptions, any required survey, and any required UCC search, Buyer may object to matters disclosed in the items if: (a) the matters disclosed are a restriction upon the Property or constitute a defect or encumbrance to title to the real or personal property described in Paragraph 2 other than those permitted by this contract or liens that Seller will satisfy at closing or Buyer will assume at closing; or (b) the items show that any part of the Property lies in a special flood hazard area (an "A" or "V" zone as defined by FEMA). If the commitment or survey is revised or any new document evidencing a title exception is delivered, Buyer may object to any new matter revealed in such revision or new document. Buyer's objection must be made within the same number of days stated in this paragraph, beginning when the revision or new document is delivered to Buyer. If Paragraph 6B(1) applies, Buyer is deemed to receive the survey on the earlier of: (i) the date Buyer actually receives the survey; or (ii) the deadline specified in Paragraph 6B.
- (2) Seller may, but is not obligated to, cure Buyer's timely objections within 15 days after Seller receives the objections. The closing date will be extended as necessary to provide such time to cure the objections. If Seller fails to cure the objections by the time required, Buyer may terminate

this contract by providing written notice to Seller within 5 days after the time by which Seller must cure the objections. If Buyer terminates, the earnest money, less any independent consideration under Paragraph 7B(1), will be refunded to Buyer.

(3) Buyer's failure to timely object or terminate under this Paragraph 6D is a waiver of Buyer's right to object except that Buyer will not waive the requirements in Schedule C of the commitment.

7. PROPERTY CONDITION:

A. Present Condition: Buyer accepts the Property in its present condition except that Seller, at Seller's expense, will complete the following before closing: See special provisions

B. Feasibility Period: Buyer may terminate this contract for any reason within 60 days after the effective date (feasibility period) by providing Seller written notice of termination.

(1) Independent Consideration. (Check only one box and insert amounts.)

(a) If Buyer terminates under this Paragraph 7B, the earnest money will be refunded to Buyer less \$ 1,500.00 that Seller will retain as independent consideration for Buyer's unrestricted right to terminate. Buyer has tendered the independent consideration to Seller upon payment of the amount specified in Paragraph 5A to the title company. The independent consideration is to be credited to the sales price only upon closing of the sale. If no dollar amount is stated in this Paragraph 7B(1) or if Buyer fails to deposit the earnest money, Buyer will not have the right to terminate under this Paragraph 7B.

(b) Not later than 3 days after the effective date, Buyer must pay \$ N/A as independent consideration for Buyer's right to terminate by tendering such amount to the title company. Buyer authorizes escrow agent to release and deliver the independent consideration to Seller at any time upon Seller's request without further notice to or consent from Buyer. If Buyer terminates under this Paragraph 7B, the earnest money will be refunded to Buyer and Seller will retain the independent consideration. The independent consideration will be credited to the sales price only upon closing of the sale. If no dollar amount is stated in this Paragraph 7B(1)(b) or if Buyer fails to pay the independent consideration, Buyer will not have the right to terminate under this Paragraph 7B.

(2) Feasibility Period Extension: Prior to the expiration of the initial feasibility period, Buyer may extend the feasibility period for a single additional period of N/A days by delivering \$N/A to the title company as additional earnest money.

(a) \$N/A of the additional earnest money will be retained by Seller as additional independent consideration for Buyer's unrestricted right to terminate, but will be credited to the sales price only upon closing of the sale. If Buyer terminates under this Paragraph 7B, the additional earnest money will be refunded to Buyer and Seller will retain the additional independent consideration.

(b) Buyer authorizes escrow agent to release and deliver to Seller the following at any time upon Seller's request without further notice to or consent from Buyer:

(i) The additional independent consideration.

(ii) (Check no boxes or only one box.)

all or \$ N/A of the remaining portion of the additional earnest money, which will be refunded to Buyer if Buyer terminates under this Paragraph 7B or if Seller defaults under this contract.

If no dollar amount is stated in this Paragraph 7B(2) as additional earnest money or as additional independent consideration, or if Buyer fails to timely deliver the additional earnest money, the extension of the feasibility period will not be effective.

C. Inspections, Studies, or Assessments:

- (1) During the feasibility period, Buyer, at Buyer's expense, may complete or cause to be completed any and all inspections, studies, or assessments of the Property (including all improvements and fixtures) desired by Buyer.
- (2) Seller, at Seller's expense, will turn on all utilities necessary for Buyer to make inspections, studies, or assessments.
- (3) Buyer must:
 - (a) employ only trained and qualified inspectors and assessors;
 - (b) notify Seller, in advance, of when the inspectors or assessors will be on the Property;
 - (c) abide by any reasonable entry rules or requirements of Seller;
 - (d) not interfere with existing operations or occupants of the Property; and
 - (e) restore the Property to its original condition if altered due to inspections, studies, or assessments that Buyer completes or causes to be completed.
- (4) Except for those matters that arise from the negligence of Seller or Seller's agents, Buyer is responsible for any claim, liability, encumbrance, cause of action, and expense resulting from Buyer's inspections, studies, or assessments, including any property damage or personal injury. Buyer will indemnify, hold harmless, and defend Seller and Seller's agents against any claim involving a matter for which Buyer is responsible under this paragraph. This paragraph survives termination of this contract.

D. Property Information:

- (1) Delivery of Property Information: Within 7 days after the effective date, Seller will deliver to Buyer the following to the extent in Seller's possession: *(Check all that apply.)*
 - (a) a current rent roll of all leases affecting the Property certified by Seller as true and correct;
 - (b) copies of all current leases, including any mineral leases, pertaining to the Property, including any modifications, supplements, or amendments to the leases;
 - (c) a current inventory of all personal property to be conveyed under this contract and copies of any leases for such personal property;
 - (d) copies of all notes and deeds of trust against the Property that Buyer will assume or that Seller will not pay in full on or before closing;
 - (e) copies of all current service, utility, maintenance, and management agreements relating to the ownership and operation of the Property;
 - (f) copies of current utility capacity letters from the Property's water and sewer service provider;
 - (g) copies of all current warranties and guaranties relating to all or part of the Property;
 - (h) copies of fire, hazard, liability, and other insurance policies that currently relate to the Property;
 - (i) copies of all leasing or commission agreements that currently relate to the tenants of all or part of the Property;
 - (j) a copy of the "as-built" plans and specifications and plat of the Property;
 - (k) copies of all invoices for utilities and repairs incurred by Seller for the Property in the 24 months immediately preceding the effective date;
 - (l) a copy of Seller's income and expense statement for the Property from _____ to _____;
 - (m) copies of all previous environmental assessments, geotechnical reports, studies, or analyses made on or relating to the Property;

- (n) real and personal property tax statements for the Property for the previous 2 calendar years;
- (o) Tenant reconciliation statements including, operating expenses, insurance and taxes for the Property from _____ to _____; and
- (p) _____

(2) Return of Property Information: If this contract terminates for any reason, Buyer will, not later than 10 days after the termination date: *(Check all that apply.)*

- (a) return to Seller all those items described in Paragraph 7D(1) that Seller delivered to Buyer in other than an electronic format and all copies that Buyer made of those items;
- (b) delete or destroy all electronic versions of those items described in Paragraph 7D(1) that Seller delivered to Buyer or Buyer copied in any format; and
- (c) deliver to Seller copies of all inspection and assessment reports related to the Property that Buyer completed or caused to be completed.

This Paragraph 7D(2) survives termination of this contract.

E. Contracts Affecting Operations: Until closing, Seller: (1) will operate the Property in the same manner as on the effective date under reasonably prudent business standards; and (2) will not transfer or dispose of any part of the Property, any interest or right in the Property, or any of the personal property or other items described in Paragraph 2B or sold under this contract. After the feasibility period ends, Seller may not enter into, amend, or terminate any other contract that affects the operations of the Property without Buyer's written approval.

8. LEASES:

A. Each written lease Seller is to assign to Buyer under this contract must be in full force and effect according to its terms. Seller may not enter into any new lease, fail to comply with any existing lease, or make any amendment or modification to any existing lease without Buyer's written consent. Seller must disclose, in writing, if any of the following exist at the time Seller provides the leases to the Buyer or subsequently occur before closing:

- (1) any failure by Seller to comply with Seller's obligations under the leases;
- (2) any circumstances under any lease that entitle the tenant to terminate the lease or seek any offsets or damages;
- (3) any non-occupancy of the leased premises by a tenant;
- (4) any advance sums paid by a tenant under any lease;
- (5) any concessions, bonuses, free rents, rebates, brokerage commissions, or other matters that affect any lease; and
- (6) any amounts payable under the leases that have been assigned or encumbered, except as security for loan(s) assumed or taken subject to under this contract.

B. Estoppel Certificates: Within N/A days after the effective date, Seller will deliver to Buyer estoppel certificates signed not earlier than N/A by each tenant that leases space in the Property. The estoppel certificates must include the certifications contained in the current version of TXR Form 1938 - Commercial Tenant Estoppel Certificate and any additional information requested by a third party lender providing financing under Paragraph 4 if the third party lender requests such additional information at least 10 days prior to the earliest date that Seller may deliver the signed estoppel certificates.

9. BROKERS:

A. The brokers to this sale are:

Principal Broker: Clark Isenhour Real Estate Services, LLC
Agent: Josh Isenhour
Address: 4270 SH 6 S, Suite 200
College Station, TX 77845
Phone & Fax: (979)268-6840
E-mail: josh@clarkisenhour.com
License No.: 506325

Cooperating Broker: N/A
Agent: _____
Address: _____
Phone & Fax: _____
E-mail: _____
License No.: _____

Principal Broker: *(Check only one box)*

- represents Seller only.
- represents Buyer only.
- is an intermediary between Seller and Buyer.

Cooperating Broker represents Buyer.

B. Fees: *(Check only (1) or (2) below.)*

(Complete the Agreement Between Brokers on page 15 only if (1) is selected.)

(1) Seller will pay Principal Broker the fee specified by separate written commission agreement between Principal Broker and Seller. Principal Broker will pay Cooperating Broker the fee specified in the Agreement Between Brokers found below the parties' signatures to this contract.

(2) At the closing of this sale, Seller will pay:

Principal Broker a total cash fee of:
 N/A % of the sales price.
 N/A

Cooperating Broker a total cash fee of:
 N/A % of the sales price.
 N/A

The cash fees will be paid in Brazos County, Texas. Seller authorizes the title company to pay the brokers from the Seller's proceeds at closing.

NOTICE: Chapter 62, Texas Property Code, authorizes a broker to secure an earned commission with a lien against the Property.

C. The parties may not amend this Paragraph 9 without the written consent of the brokers affected by the amendment.

10. CLOSING:

A. The date of the closing of the sale (closing date) will be on or before the later of:

(1) 30 days after the expiration of the feasibility period.

_____ *(specific date)*.

(2) 7 days after objections made under Paragraph 6D have been cured or waived.

B. If either party fails to close by the closing date, the non-defaulting party may exercise the remedies in Paragraph 15.

- C. At closing, Seller will execute and deliver to Buyer, at Seller's expense, a general special warranty deed. The deed must include a vendor's lien if any part of the sales price is financed. The deed must convey good and indefeasible title to the Property and show no exceptions other than those permitted under Paragraph 6 or other provisions of this contract. Seller must convey the Property:
- (1) with no liens, assessments, or Uniform Commercial Code or other security interests against the Property which will not be satisfied out of the sales price, unless securing loans Buyer assumes;
 - (2) without any assumed loans in default; and
 - (3) with no persons in possession of any part of the Property as lessees, tenants at sufferance, or trespassers except tenants under the written leases assigned to Buyer under this contract.
- D. At closing, Seller, at Seller's expense, will also deliver to Buyer:
- (1) tax statements showing no delinquent taxes on the Property;
 - (2) a bill of sale with warranties to title conveying title, free and clear of all liens, to any personal property defined as part of the Property in Paragraph 2 or sold under this contract;
 - (3) an assignment of all leases to or on the Property;
 - (4) to the extent that the following items are assignable, an assignment to Buyer of the following items as they relate to the Property or its operations:
 - (a) licenses and permits;
 - (b) service, utility, maintenance, management, and other contracts; and
 - (c) warranties and guaranties;
 - (5) a rent roll current on the day of the closing certified by Seller as true and correct;
 - (6) evidence that the person executing this contract is legally capable and authorized to bind Seller;
 - (7) an affidavit acceptable to the title company stating that Seller is not a foreign person or, if Seller is a foreign person, a written authorization for the title company to: (i) withhold from Seller's proceeds an amount sufficient to comply with applicable tax law; and (ii) deliver the amount to the Internal Revenue Service together with appropriate tax forms; and
 - (8) any notices, statements, certificates, affidavits, releases, and other documents required by this contract, the commitment, or law necessary for the closing of the sale and the issuance of the title policy, all of which must be completed and executed by Seller as necessary.
- E. At closing, Buyer will:
- (1) pay the sales price in good funds acceptable to the title company;
 - (2) deliver evidence that the person executing this contract is legally capable and authorized to bind Buyer;
 - (3) sign and send to each tenant in the Property a written statement that:
 - (a) acknowledges Buyer has received and is responsible for the tenant's security deposit; and
 - (b) specifies the exact dollar amount of the security deposit;
 - (4) sign an assumption of all leases then in effect; and
 - (5) execute and deliver any notices, statements, certificates, or other documents required by this contract or law necessary to close the sale.
- F. Unless the parties agree otherwise, the closing documents will be as found in the basic forms in the current edition of the State Bar of Texas Real Estate Forms Manual without any additional clauses.

11. POSSESSION: Seller will deliver possession of the Property to Buyer upon closing and funding of this sale in its present condition with any repairs Seller is obligated to complete under this contract, ordinary wear and tear excepted. Any possession by Buyer before closing or by Seller after closing that is not authorized by a separate written lease agreement is a landlord-tenant at sufferance relationship between the parties.

12. SPECIAL PROVISIONS: The following special provisions apply and will control in the event of a conflict with other provisions of this contract. *(If special provisions are contained in an Addendum, identify the Addendum here and reference the Addendum in Paragraph 22D.)*

The Seller shall terminate the existing lease on the Property and cause the tenant to vacate the property prior to closing. If the Seller chooses to wait until after the expiration of the Feasibility Period to terminate the lease and cause the tenant to vacate the Property, the closing will be extended until a date that is fifteen (15) days after the tenant has vacated the Property. If the Seller has not caused the tenant to vacate within ninety (90) days after the termination of the Feasibility Period, the Buyer will have the option, at any time, to terminate the Contract and the Earnest Money shall be refunded to the Buyer less \$1,500 which shall be paid to the Seller as independent consideration.

13. SALES EXPENSES:

A. Seller's Expenses: Seller will pay for the following at or before closing:

- (1) releases of existing liens, other than those liens assumed by Buyer, including prepayment penalties and recording fees;
- (2) release of Seller's loan liability, if applicable;
- (3) tax statements or certificates;
- (4) preparation of the deed and any bill of sale;
- (5) one-half of any escrow fee;
- (6) costs to record any documents to cure title objections that Seller must cure; and
- (7) other expenses that Seller will pay under other provisions of this contract.

B. Buyer's Expenses: Buyer will pay for the following at or before closing:

- (1) all loan expenses and fees;
- (2) preparation fees of any deed of trust;
- (3) recording fees for the deed and any deed of trust;
- (4) premiums for flood and hazard insurance as may be required by Buyer's lender;
- (5) one-half of any escrow fee; and
- (6) other expenses that Buyer will pay under other provisions of this contract.

14. PRORATIONS:

A. Prorations:

- (1) Interest on any assumed loan, taxes, rents, and any expense reimbursements from tenants will be prorated through the closing date.
- (2) If the amount of ad valorem taxes for the year in which the sale closes is not available on the closing date, taxes will be prorated on the basis of taxes assessed in the previous year. If the taxes for the year in which the sale closes vary from the amount prorated at closing, the parties will adjust the prorations when the tax statements for the year in which the sale closes become available. This Paragraph 14A(2) survives closing.
- (3) If Buyer assumes a loan or is taking the Property subject to an existing lien, Seller will transfer all reserve deposits held by the lender for the payment of taxes, insurance premiums, and other charges to Buyer at closing and Buyer will reimburse such amounts to Seller by an appropriate adjustment at closing.

B. Rollback Taxes: If Seller's use or change in use of the Property before closing results in the assessment of additional taxes, penalties, or interest (assessments) for periods before closing, the assessments will be the obligation of Seller. If this sale or Buyer's use of the Property after closing results in additional assessments for periods before closing, the assessments will be the obligation of Buyer. This Paragraph 14B survives closing.

C. Rent and Security Deposits: At closing, Seller will tender to Buyer all security deposits and the following advance payments received by Seller for periods after closing: prepaid expenses, advance rental payments, and other advance payments paid by tenants. Rents prorated to one party but received by the other party will be remitted by the recipient to the party to whom it was prorated within 5 days after the rent is received. This Paragraph 14C survives closing.

15. DEFAULT:

A. If Buyer fails to comply with this contract, Buyer is in default and Seller, as Seller's sole remedy(ies), may terminate this contract and receive the earnest money, as liquidated damages for Buyer's failure except for any damages resulting from Buyer's inspections, studies or assessments in accordance with Paragraph 7C(4) which Seller may pursue, or

(Check if applicable)

enforce specific performance, or seek such other relief as may be provided by law.

B. If, without fault, Seller is unable within the time allowed to deliver the estoppel certificates, survey or the commitment, Buyer may:

(1) terminate this contract and receive the earnest money, less any independent consideration under Paragraph 7B(1), as liquidated damages and as Buyer's sole remedy; or

(2) extend the time for performance up to 15 days and the closing will be extended as necessary.

C. Except as provided in Paragraph 15B, if Seller fails to comply with this contract, Seller is in default and Buyer may:

(1) terminate this contract and receive the earnest money, less any independent consideration under Paragraph 7B(1), as liquidated damages and as Buyer's sole remedy; or

(2) enforce specific performance, or seek such other relief as may be provided by law, or both.

16. CASUALTY LOSS AND CONDEMNATION:

A. If any part of the Property is damaged or destroyed by fire or other casualty after the effective date, Seller must restore the Property to its previous condition as soon as reasonably possible and not later than the closing date. If, without fault, Seller is unable to do so, Buyer may:

(1) terminate this contract and the earnest money, less any independent consideration under Paragraph 7B(1), will be refunded to Buyer;

(2) extend the time for performance up to 15 days and closing will be extended as necessary; or

(3) accept at closing: (i) the Property in its damaged condition; (ii) an assignment of any insurance proceeds Seller is entitled to receive along with the insurer's consent to the assignment; and (iii) a credit to the sales price in the amount of any unpaid deductible under the policy for the loss.

B. If before closing, condemnation proceedings are commenced against any part of the Property, Buyer may:

(1) terminate this contract by providing written notice to Seller within 15 days after Buyer is advised of the condemnation proceedings and the earnest money, less any independent consideration under Paragraph 7B(1), will be refunded to Buyer; or

(2) appear and defend the condemnation proceedings and any award will, at Buyer's election, belong to: (a) Seller and the sales price will be reduced by the same amount; or (b) Buyer and the sales price will not be reduced.

17. ATTORNEY'S FEES: If Buyer, Seller, any broker, or the title company is a prevailing party in any legal proceeding brought under or with relation to this contract or this transaction, such party is entitled to recover from the non-prevailing parties all costs of such proceeding and reasonable attorney's fees. This Paragraph 17 survives termination of this contract.

18. ESCROW:

- A. At closing, the earnest money will be applied first to any cash down payment, then to Buyer's closing costs, and any excess will be refunded to Buyer. If no closing occurs, the title company may require payment of unpaid expenses incurred on behalf of the parties and a written release of liability of the title company from all parties.
- B. If one party makes written demand for the earnest money, the title company will give notice of the demand by providing to the other party a copy of the demand. If the title company does not receive written objection to the demand from the other party within 15 days after the date the title company sent the demand to the other party, the title company may disburse the earnest money to the party making demand, reduced by the amount of unpaid expenses incurred on behalf of the party receiving the earnest money and the title company may pay the same to the creditors.
- C. The title company will deduct any independent consideration under Paragraph 7B(1) before disbursing any earnest money to Buyer and will pay the independent consideration to Seller.
- D. If the title company complies with this Paragraph 18, each party hereby releases the title company from all claims related to the disbursement of the earnest money.
- E. Notices under this Paragraph 18 must be sent by certified mail, return receipt requested. Notices to the title company are effective upon receipt by the title company.
- F. Any party who wrongfully fails or refuses to sign a release acceptable to the title company within 7 days after receipt of the request will be liable to the other party for: (i) damages; (ii) the earnest money; (iii) reasonable attorney's fees; and (iv) all costs of suit.
- G. Seller Buyer intend(s) to complete this transaction as a part of an exchange of like-kind properties in accordance with Section 1031 of the Internal Revenue Code, as amended. All expenses in connection with the contemplated exchange will be paid by the exchanging party. The other party will not incur any expense or liability with respect to the exchange. The parties agree to cooperate fully and in good faith to arrange and consummate the exchange so as to comply to the maximum extent feasible with the provisions of Section 1031 of the Internal Revenue Code. The other provisions of this contract will not be affected in the event the contemplated exchange fails to occur.

19. MATERIAL FACTS: To the best of Seller's knowledge and belief: *(Check only one box.)*

- A. Seller is not aware of any material defects to the Property except as stated in the attached Commercial Property Condition Statement (TXR-1408).
- B. Except as otherwise provided in this contract, Seller is not aware of:
- (1) any subsurface: structures, pits, waste, springs, or improvements;
 - (2) any pending or threatened litigation, condemnation, or assessment affecting the Property;
 - (3) any environmental hazards or conditions that materially affect the Property;
 - (4) whether the Property is or has been used for the storage or disposal of hazardous materials or toxic waste, a dump site or landfill, or any underground tanks or containers;
 - (5) whether radon, asbestos containing materials, urea-formaldehyde foam insulation, lead-based paint, toxic mold (to the extent that it adversely affects the health of ordinary occupants), or other pollutants or contaminants of any nature now exist or ever existed on the Property;
 - (6) any wetlands, as defined by federal or state law or regulation, on the Property;
 - (7) any threatened or endangered species or their habitat on the Property;
 - (8) any present or past infestation of wood-destroying insects in the Property's improvements;
 - (9) any contemplated material changes to the Property or surrounding area that would materially and detrimentally affect the ordinary use of the Property;

- (10) any material physical defects in the improvements on the Property; or
- (11) any condition on the Property that violates any law or ordinance.

(Describe any exceptions to (1)-(11) in Paragraph 12 or an addendum.)

20. NOTICES: All notices between the parties under this contract must be in writing and are effective when hand-delivered, mailed by certified mail return receipt requested, sent by a national or regional overnight delivery service that provides a delivery receipt, or sent by confirmed facsimile transmission to the parties addresses or facsimile numbers stated in Paragraph 1. The parties will send copies of any notices to the broker representing the party to whom the notices are sent.

- A. Seller also consents to receive any notices by e-mail at Seller's e-mail address stated in Paragraph 1.
- B. Buyer also consents to receive any notices by e-mail at Buyer's e-mail address stated in Paragraph 1.

21. DISPUTE RESOLUTION: The parties agree to negotiate in good faith in an effort to resolve any dispute related to this contract that may arise. If the dispute cannot be resolved by negotiation, the parties will submit the dispute to mediation before resorting to arbitration or litigation and will equally share the costs of a mutually acceptable mediator. This paragraph survives termination of this contract. This paragraph does not preclude a party from seeking equitable relief from a court of competent jurisdiction.

22. AGREEMENT OF THE PARTIES:

A. This contract is binding on the parties, their heirs, executors, representatives, successors, and permitted assigns. This contract is to be construed in accordance with the laws of the State of Texas. If any term or condition of this contract shall be held to be invalid or unenforceable, the remainder of this contract shall not be affected thereby. All individuals signing represent that they have the authority to sign on behalf of and bind the party for whom they are signing.

B. This contract contains the entire agreement of the parties and may not be changed except in writing.

C. If this contract is executed in a number of identical counterparts, each counterpart is an original and all counterparts, collectively, constitute one agreement.

D. Addenda which are part of this contract are: *(Check all that apply.)*

- (1) Property Description Exhibit identified in Paragraph 2;
- (2) Commercial Contract Condominium Addendum (TXR-1930) or (TXR-1946);
- (3) Commercial Contract Financing Addendum (TXR-1931);
- (4) Commercial Property Condition Statement (TXR-1408);
- (5) Commercial Contract Addendum for Special Provisions (TXR-1940);
- (6) Addendum for Seller's Disclosure of Information on Lead-Based Paint and Lead-Based Paint Hazards (TXR-1906);
- (7) Notice to Purchaser of Real Property in a Water District (MUD);
- (8) Addendum for Coastal Area Property (TXR-1915);
- (9) Addendum for Property Located Seaward of the Gulf Intracoastal Waterway (TXR-1916);
- (10) Information About Brokerage Services (TXR-2501);
- (11) Information About Mineral Clauses in Contract Forms (TXR-2509);
- (12) Notice of Obligation to Pay Improvement District Assessment (TXR-1955, PID);
- (13) _____

(Note: Counsel for Texas REALTORS® has determined that any of the foregoing addenda which are promulgated by the Texas Real Estate Commission (TREC) or published by Texas REALTORS® are appropriate for use with this form.)

E. Buyer may may not assign this contract. If Buyer assigns this contract, Buyer will be relieved of any future liability under this contract only if the assignee assumes, in writing, all of Buyer's obligations under this contract.

23. TIME: Time is of the essence in this contract. The parties require strict compliance with the times for performance. If the last day to perform under a provision of this contract falls on a Saturday, Sunday, or Federal Reserve Bank holiday, the time for performance is extended until the end of the next day which is not a Saturday, Sunday, or Federal Reserve Bank holiday.

24. EFFECTIVE DATE: The effective date of this contract for the purpose of performance of all obligations is the date the title company receipts this contract after all parties execute this contract.

25. ADDITIONAL NOTICES:

A. Buyer should have an abstract covering the Property examined by an attorney of Buyer's selection, or Buyer should be furnished with or obtain a title policy.

B. If the Property is situated in a utility or other statutorily created district providing water, sewer, drainage, or flood control facilities and services, Chapter 49, Texas Water Code, requires Seller to deliver and Buyer to sign the statutory notice relating to the tax rate, bonded indebtedness, or standby fees of the district before final execution of this contract.

C. Notice Required by §13.257, Water Code: "The real property, described below, that you are about to purchase may be located in a certificated water or sewer service area, which is authorized by law to provide water or sewer service to the properties in the certificated area. If your property is located in a certificated area there may be special costs or charges that you will be required to pay before you can receive water or sewer service. There may be a period required to construct lines or other facilities necessary to provide water or sewer service to your property. You are advised to determine if the property is in a certificated area and contact the utility service provider to determine the cost that you will be required to pay and the period, if any, that is required to provide water or sewer service to your property. The undersigned purchaser hereby acknowledges receipt of the foregoing notice at or before the execution of a binding contract for the purchase of the real property described in the notice or at closing of purchase of the real property." The real property is described in Paragraph 2 of this contract.

D. If the Property adjoins or shares a common boundary with the tidally influenced submerged lands of the state, §33.135, Texas Natural Resources Code, requires a notice regarding coastal area property to be included as part of this contract (*the Addendum for Coastal Area Property (TXR-1915) may be used*).

E. If the Property is located seaward of the Gulf Intracoastal Waterway, §61.025, Texas Natural Resources Code, requires a notice regarding the seaward location of the Property to be included as part of this contract (*the Addendum for Property Located Seaward of the Gulf Intracoastal Waterway (TXR-1916) may be used*).

F. If the Property is located outside the limits of a municipality, the Property may now or later be included in the extra-territorial jurisdiction (ETJ) of a municipality and may now or later be subject to annexation by the municipality. Each municipality maintains a map that depicts its boundaries and ETJ. To determine if the Property is located within a municipality's ETJ, Buyer should contact all municipalities located in the general proximity of the Property for further information.

G. If apartments or other residential units are on the Property and the units were built before 1978, federal law requires a lead-based paint and hazard disclosure statement to be made part of this contract (*the Addendum for Seller's Disclosure of Information on Lead-Based Paint and Lead-Based Paint Hazards (TXR-1906) may be used*).

- H. Section 1958.154, Occupations Code requires Seller to provide Buyer a copy of any mold remediation certificate issued for the Property during the 5 years preceding the date the Seller sells the Property.
- I. Brokers are not qualified to perform property inspections, surveys, engineering studies, environmental assessments, or inspections to determine compliance with zoning, governmental regulations, or laws. Buyer should seek experts to perform such services. Buyer should review local building codes, ordinances and other applicable laws to determine their effect on the Property. Selection of experts, inspectors, and repairmen is the responsibility of Buyer and not the brokers. Brokers are not qualified to determine the credit worthiness of the parties. NOTICE OF WATER LEVEL FLUCTUATIONS: If the Property adjoins an impoundment of water, including a reservoir or lake, constructed and maintained under Chapter 11, Water Code, that has a storage capacity of at least 5,000 acre-feet at the impoundment's normal operating level, Seller hereby notifies Buyer: "The water level of the impoundment of water adjoining the Property fluctuates for various reasons, including as a result of: (1) an entity lawfully exercising its right to use the water stored in the impoundment; or (2) drought or flood conditions."
- J. PUBLIC IMPROVEMENT DISTRICTS: If the Property is in a public improvement district, Seller is required by §5.014, Property Code to give Buyer a written notice concerning the obligation to pay assessments. The form of the required notice is available as a part of the Notice of Obligation to Pay Improvement District Assessment (TXR-1955).
- K. LICENSE HOLDER DISCLOSURE: Texas law requires a real estate license holder who is a party to a transaction or acting on behalf of a spouse, parent, child, business entity in which the license holder owns more than 10%, or a trust for which the license holder acts as a trustee or of which the license holder or the license holder's spouse, parent or child is a beneficiary, to notify the other party in writing before entering into a contract of sale. Disclose if applicable: Josh Isenhour is a licensed TREC Real Estate Broker and principal in Mesquite Properties JV

26. **CONTRACT AS OFFER:** The execution of this contract by the first party constitutes an offer to buy or sell the Property. Unless the other party accepts the offer by 5:00 p.m., in the time zone in which the Property is located, on June 12, 2026, the offer will lapse and become null and void.

READ THIS CONTRACT CAREFULLY. The brokers and agents make no representation or recommendation as to the legal sufficiency, legal effect, or tax consequences of this document or transaction. CONSULT your attorney BEFORE signing.

Seller: Mesquite Properties Joint Venture

Buyer: Mike Gentry and/or Assigns

By: _____
By (signature): _____
Printed Name: _____
Title: _____

By: _____
By (signature): _____
Printed Name: _____
Title: _____

By: _____
By (signature): _____
Printed Name: _____
Title: _____

By: _____
By (signature): _____
Printed Name: _____
Title: _____

AGREEMENT BETWEEN BROKERS

(use only if Paragraph 9B(1) is effective)

Principal Broker agrees to pay N/A (Cooperating Broker) a fee when the Principal Broker's fee is received. The fee to be paid to Cooperating Broker will be:

- \$ N/A, or
- N/A % of the sales price, or
- N/A % of the Principal Broker's fee.

The title company is authorized and directed to pay Cooperating Broker from Principal Broker's fee at closing. This Agreement Between Brokers supersedes any prior offers and agreements for compensation between brokers.

Principal Broker: _____ Cooperating Broker: _____

By: _____ By: _____

ATTORNEYS

Seller's attorney: _____ Buyer's attorney: Mike Gentry

Address: _____ Address: 1515 Emerald Pkwy

College Station, TX 77845

Phone & Fax: _____ Phone & Fax: (979)694-7000

E-mail: _____ E-mail: mike.gentry@westwebblaw.com

Seller's attorney requests copies of documents, notices, and other information:

- the title company sends to Seller.
- Buyer sends to Seller.

Buyer's attorney requests copies of documents, notices, and other information:

- the title company sends to Buyer.
- Seller sends to Buyer.

ESCROW RECEIPT

The title company acknowledges receipt of:

- A. the contract on this day _____ (effective date);
- B. earnest money in the amount of \$ _____ in the form of _____ on _____.

Title company: _____ Address: _____

By: _____ Phone & Fax: _____

Assigned file number (GF#): _____ E-mail: _____



Information About Brokerage Services

11-03-2025



Texas law requires all real estate license holders to give the following information about brokerage services to prospective buyers, tenants, sellers and landlords.

TYPES OF REAL ESTATE LICENSE HOLDERS:

- A **BROKER** is responsible for all brokerage activities, including acts performed by sales agents sponsored by the broker.
- A **SALES AGENT** must be sponsored by a broker and works with clients on behalf of the broker.

A BROKER'S MINIMUM DUTIES REQUIRED BY LAW (A client is the person or party that the broker represents):

- Put the interests of the client above all others, including the broker's own interests;
- Inform the client of any material information about the property or transaction received by the broker;
- Answer the client's questions and present any offer to or counter-offer from the client; and
- Treat all parties to a real estate transaction honestly and fairly.

WRITTEN AGREEMENTS ARE REQUIRED IN CERTAIN SITUATIONS: A license holder who performs brokerage activity for a prospective buyer of residential property must enter into a written agreement with the buyer before showing any residential property to the buyer or if no residential property will be shown, before presenting an offer on behalf of the buyer. This written agreement must contain specific information required by Texas law. For more information on these requirements, see section 1101.563 of the Texas Occupations Code. Even if a written agreement is not required, to avoid disputes, all agreements between you and a broker should be in writing and clearly establish: (i) the broker's duties and responsibilities to you and your obligations under the agreement; and (ii) the amount or rate of compensation the broker will receive and how this amount is determined.

A LICENSE HOLDER CAN REPRESENT A PARTY IN A REAL ESTATE TRANSACTION:

AS AGENT FOR OWNER (SELLER/LANDLORD): The broker becomes the property owner's agent through an agreement with the owner, usually in a written listing to sell or property management agreement. An owner's agent must perform the broker's minimum duties above and must inform the owner of any material information about the property or transaction known by the agent, including information disclosed to the agent by the buyer or buyer's agent. An owner's agent fees are not set by law and are fully negotiable.

AS AGENT FOR BUYER/TENANT: The broker becomes the buyer/tenant's agent by agreeing to represent the buyer, usually through a written representation agreement. A buyer's agent must perform the broker's minimum duties above and must inform the buyer of any material information about the property or transaction known by the agent, including information disclosed to the agent by the seller or seller's agent. A buyer/tenant's agent fees are not set by law and are fully negotiable.

AS AGENT FOR BOTH - INTERMEDIARY: To act as an intermediary between the parties the broker must first obtain the written agreement of each party to the transaction. The written agreement must state who will pay the broker and, in conspicuous bold or underlined print, set forth the broker's obligations as an intermediary. A broker who acts as an intermediary:

- Must treat all parties to the transaction impartially and fairly;
- May, with the parties' written consent, appoint a different license holder associated with the broker to each party (owner and buyer) to communicate with, provide opinions and advice to, and carry out the instructions of each party to the transaction.
- Must not, unless specifically authorized in writing to do so by the party, disclose:
 - o that the owner will accept a price less than the written asking price;
 - o that the buyer/tenant will pay a price greater than the price submitted in a written offer; and
 - o any confidential information or any other information that a party specifically instructs the broker in writing not to disclose, unless required to do so by law.

A LICENSE HOLDER CAN SHOW PROPERTY TO A BUYER/TENANT WITHOUT REPRESENTING THE BUYER/TENANT IF:

- The broker has not agreed with the buyer/tenant, either orally or in writing, to represent the buyer/tenant;
- The broker is not otherwise acting as the buyer/tenant's agent at the time of showing the property;
- The broker does not provide the buyer/tenant opinions or advice regarding the property or real estate transactions generally; and
- The broker does not perform any other act of real estate brokerage for the buyer/tenant.

Before showing a residential property to an unrepresented prospective buyer, a license holder must enter into a written agreement that contains the information required by section 1101.563 of the Texas Occupations Code. The agreement may not be exclusive and must be limited to no more than 14 days.

LICENSE HOLDER CONTACT INFORMATION: This notice is being provided for information purposes. It does not create an obligation for you to use the broker's services. Please acknowledge receipt of this notice below and retain a copy for your records.

<u>Clark Isenhour Real Estate Services, LLC</u>	<u>8999919</u>	<u>josh@clarkisenhour.com</u>	<u>(979)268-6840</u>
Name of Sponsoring Broker (Licensed Individual or Business Entity)	License No.	Email	Phone
<u>Josh Isenhour</u>	<u>506325</u>	<u>josh@clarkisenhour.com</u>	<u>(979)268-6840</u>
Name of Designated Broker of Licensed Business Entity, if applicable	License No.	Email	Phone
_____ Name of Licensed Supervisor of Sales Agent/Associate, if applicable	_____ License No.	_____ Email	_____ Phone
<u>Josh Isenhour</u>	<u>506325</u>	<u>josh@clarkisenhour.com</u>	<u>(979)268-6840</u>
Name of Sales Agent/Associate	License No.	Email	Phone

Buyer/Tenant/Seller/Landlord Initials

Date

Regulated by the Texas Real Estate Commission

Information available at www.trec.texas.gov

IABS 1-2

Clark Isenhour Real Estate Services, LLC, 3828 S. College Avenue Bryan TX 77801
Josh Isenhour

Phone: 9792686840

Fax:

108 San Jacinto

Produced with Lone Wolf Transactions (zipForm Edition) 717 N Harwood St, Suite 2200, Dallas, TX 75201 www.lwolf.com

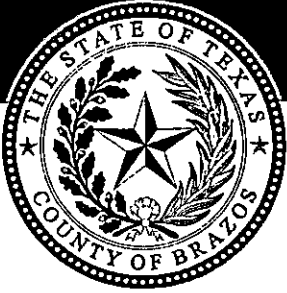

BRAZOS COUNTY
REQUEST FOR BUDGET AMENDMENT

Budget
Amendment
Number*

Budget Amendment Number

19.04

Agenda Date

6/23/2026

Fiscal Year

October 1 - September 30 2026

Requesting Department

BUDGET OFFICE

Requestors Name

Nina Payne

DECREASE EXPENDITURE(S):

45000 Capital Improvement Fun

From: Fund Number

DECREASE EXPENDITURE(S):

63145001 Project Management

From: Division Name

DECREASE EXPENDITURE(S):

80890000 Vehicles

From: Account Number

From: Amount

\$

2,926.50

AMOUNT OF DECREASE

DECREASE EXPENDITURE(S):

45000 Capital Improvement Fun

From: Fund Number

DECREASE EXPENDITURE(S):

63280021 Sheriff Office - Jail - C

From: Division Name

DECREASE EXPENDITURE(S):

80286000 Equipment - Other

From: Account Number

From: Amount

\$

7,822.00

AMOUNT OF DECREASE

DECREASE EXPENDITURE(S):

45000 Capital Improvement Fun

From: Fund Number

DECREASE EXPENDITURE(S):

63280021 Sheriff Office - Jail - C

From: Division Name

DECREASE EXPENDITURE(S):

80286000 Equipment - Other

From: Account Number

From: Amount

\$

136.50

AMOUNT OF DECREASE

Total

\$ 10,885.00

TOTAL AMOUNT OF DECREASE

INCREASE EXPENDITURE(S):

45000 Capital Improvement Fun

To: Fund Number

INCREASE EXPENDITURE(S):

63112101 Elections Administrat

To: Division Name

INCREASE EXPENDITURE(S):

80670000 Printers

To: Account Number

To: Amount

\$

10,885.00

AMOUNT OF INCREASE

Total

\$ 10,885.00

TOTAL AMOUNT OF INCREASE

TO EXPLANATION AND SIGNATURE

Explanation

Explanation to reclassify budget to proper accounts:

Reallocation of funds to the appropriate account to purchase a replacement printer to operate with the Hart Verity System.

File and Documentation

File Upload

Upload

Signature

Initiator

Mina Payne

Department (?)

BUDGET OFFICE

Signature

Elected Official/Dept Head

Mina Payne

Comments

Elected Official/Dept Head Comments

Signature

Budget Officer Signature

Spencer A Mays

Budget Officer Comments

CC Approval Oracle Posted

Sign

Completion Date

Date will be captured on form submission

Comments

Commissioners Court Decision Comments

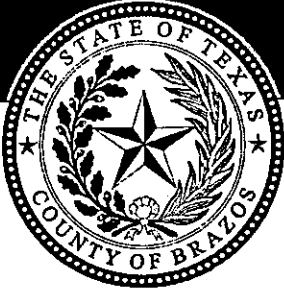

BRAZOS COUNTY
REQUEST FOR BUDGET AMENDMENT

Budget
Amendment
Number*

Budget Amendment Number

19.05

Agenda Date

6/23/2026

Fiscal Year

October 1 - September 30 2026

Requesting Department

BUDGET OFFICE

Requestors Name

Nina Payne

DECREASE EXPENDITURE(S):

43231 Off System Road Bond

From: Fund Number

DECREASE EXPENDITURE(S):

63432356 Road & Bridge

From: Division Name

DECREASE EXPENDITURE(S):

80715000 Roads - Capital

From: Account Number

From: Amount

\$

1,008,749.25

AMOUNT OF DECREASE

Total

\$ 1,008,749.25

TOTAL AMOUNT OF DECREASE

INCREASE EXPENDITURE(S):

1000 General Fund

To: Fund Number

INCREASE EXPENDITURE(S):

11001500 Contingency

To: Division Name

INCREASE EXPENDITURE(S):

61130000 Contingency

To: Account Number

To: Amount

\$

1,008,749.25

AMOUNT OF INCREASE

Total

\$ 1,008,749.25

TOTAL AMOUNT OF INCREASE

TO EXPLANATION AND SIGNATURE

Explanation

Explanation to reclassify budget to proper accounts:

Reallocation of funds to the appropriate accounts for eligible expenditures related to projects identified in the 2023 General Obligations Bonds, Series 2023 (Off System Road Bond) for FY 2026.

File and Documentation

File Upload

Upload
23-001 Resolution.pdf

1.34MB

Signature

Initiator

Nina Payne

Department (?)

BUDGET OFFICE

Signature

Elected Official/Dept Head

Nina Payne

Comments

Elected Official/Dept Head Comments

Signature

Budget Officer Signature

Spencer A Mays

Budget Officer Comments

CC Approval Oracle Posted

Sign

Completion Date

Date will be captured on form submission

Comments

Commissioners Court Decision Comments

43231 - CO 2023 Off System Road Bond

		Budgeted	BA Needed	Actual	Variance
Fund Balance	47010000	5,053,031.00		5,023,524.00	29,507.00
Transfer From General Fund	49028000	135,000.00		-	135,000.00
FY26 Actual Revenues	45*	23,000.00		102,765.23	(79,765.23)
		<u>5,211,031.00</u>		<u>5,126,289.23</u>	<u>84,741.77</u>
FY26 Actual Expenditures	80*	5,211,031.00	(1,008,749.25)	3,956,716.40	245,565.35
Transfer to General Fund (Reimburse Prior Year allowable bond expenditures	91300000	-	1,008,749.25	1,008,749.25	-
		<u>5,211,031.00</u>		<u>4,965,465.65</u>	<u>245,565.35</u>

CERTIFICATE FOR RESOLUTION

We, the undersigned County Judge and County Clerk of Brazos County, Texas (the "County") hereby certify as follows:

1. The Commissioners Court of the County (the "Commissioners Court") convened in regular session, open to the public, on January 17, 2023 at the meeting place designated in the notice (the "Meeting"), and the roll was called of the members, to wit:

Duane Peters, County Judge
Steve Aldrich, Commissioner, Pct. 1
Chuck Konderla, Commissioner, Pct. 2

Nancy Berry, Commissioner, Pct. 3
Wanda J. Watson, Commissioner, Pct. 4

All members of the Commissioners Court were present, except _____, thus constituting a quorum. Whereupon among other business, the following was transacted at the Meeting: a written

RESOLUTION DECLARING INTENTION TO REIMBURSE CERTAIN EXPENDITURES WITH BORROWING PROCEEDS

(the "Resolution") was duly introduced for the consideration of the Commissioners Court. It was then duly moved and seconded that the Resolution be finally passed and adopted; and after due discussion, such motion, carrying with it the adoption of the Resolution prevailed and carried by the following vote:

YES: 5 NOES: 0 ABSTENTIONS: 0

2. A true, full, and correct copy of the Resolution adopted at the Meeting is attached to and follows this Certificate; the Resolution has been duly recorded in the Commissioners Court's minutes of the Meeting; the above and foregoing paragraph is a true, full, and correct excerpt from the Commissioners Court's minutes of the Meeting pertaining to the adoption of the Resolution; the persons named in the above and foregoing paragraph are duly chosen, qualified, and acting officers and members of the Council as indicated therein; each of the officers and members of the Commissioners Court was duly and sufficiently notified officially and personally, in advance, of the time, place, and purpose of the Meeting, and that the Resolution would be introduced and considered for adoption at the Meeting and each of such officers and members consented, in advance, to the holding of the Meeting for such purpose; and the Meeting was open to the public, and public notice of the time, place, and purpose of the Meeting was given, all as required by Chapter 551, Texas Government Code, as amended.

3. Karen McQueen is the duly appointed and acting County Clerk of the County.

SIGNED AND SEALED this January 17, 2023.

County Clerk

County Judge



RESOLUTION DECLARING INTENTION TO REIMBURSE CERTAIN EXPENDITURES
WITH BORROWING PROCEEDS

WHEREAS, Brazos County, Texas (the "Issuer") desires to pay capital expenditures in connection with the design, planning, acquisition, construction, and/or renovating of facilities described in Exhibit A hereto (the "Project");

WHEREAS, Chapter 1201, Texas Government Code, as amended ("Chapter 1201"), permits the Issuer to use the proceeds of obligations to reimburse the Issuer for costs attributable to the Project paid or incurred before the date of issuance of the obligations for the purpose of financing public works projects, which include the Project; and

WHEREAS, the Issuer finds, considers, and declares that the reimbursement of the Issuer for the payment of such capital expenditures will be appropriate and consistent with the objectives of the Issuer's programs and, as such, chooses to declare its intention, in accordance with the provisions of Section 1.150-2 of the Treasury Regulations, to reimburse itself for such payments at such time as it issues obligations to finance the Project.

NOW, THEREFORE, BE IT RESOLVED BY THE COMMISSIONERS COURT OF BRAZOS COUNTY, TEXAS THAT:

Section 1. This Resolution declares the intention of the Issuer to reimburse the expenditures for the Project with the proceeds of a borrowing. The Issuer presently intends to reimburse the expenditure by incurring debt the interest on which is excludable from gross income under section 103 of the Internal Revenue Code of 1986, as amended.

Section 2. The Issuer reasonably expects to incur debt with an aggregate maximum principal amount now estimated to not exceed \$25,000,000 for the purpose of paying the costs of the Project.

Section 3. The Issuer intends to reimburse the expenditures hereunder not later than 18 months after the date the original expenditure is paid or the date the Project is placed in service or abandoned, but in no event more than three years after the original expenditure is paid unless the Project is a construction project for which the Issuer and a licensed architect or engineer have certified that at least five years are necessary to complete the Project in which event the maximum reimbursement period is five years after the date of the original expenditure.

Section 4. The Issuer intends that this Resolution satisfy the official intent requirement set forth in Section 1.150-2 of the Treasury Regulations and evidences its intentions under Chapter 1201.

Section 5. This Resolution shall be liberally construed to evidence the intent of the Issuer to comply with state and federal income tax law in the issuance of tax exempt obligations for the Project.

* * *

EXHIBIT A

PROJECT DESCRIPTION

Providing for the payment of contractual obligations to be incurred in connection with the design, planning, acquisition, construction, equipping, expansion, repair, renovation, and/or rehabilitation of certain County-owned public property, specifically being for the construction of: (1) roads, bridges and highways throughout the County; and (2) payment of contractual obligations for professional services in connection therewith (to wit: architectural, engineering, financial advisory, and legal).



BRAZOS COUNTY
REQUEST FOR BUDGET AMENDMENT

Budget
Amendment
Number*

Budget Amendment Number

19.06

Agenda Date

6/23/2026

Fiscal Year

October 1 - September 30 2026

Requesting Department

BUDGET OFFICE

Requestors Name

Nina Payne

DECREASE EXPENDITURE(S):

1000 General Fund

From: Fund Number

DECREASE EXPENDITURE(S):

11001500 Contingency

From: Division Name

DECREASE EXPENDITURE(S):

61130000 Contingency

From: Account Number

From: Amount

\$

42,784.00

AMOUNT OF DECREASE

Total

\$ 42,784.00

TOTAL AMOUNT OF DECREASE

INCREASE EXPENDITURE(S):

45000 Capital Improvement Fun

To: Fund Number

INCREASE EXPENDITURE(S):

63000511 Road & Bridge Renov

To: Division Name

INCREASE EXPENDITURE(S):

80101000 Building Improvement

To: Account Number

To: Amount

\$

42,784.00

AMOUNT OF INCREASE

Total

\$ 42,784.00

TOTAL AMOUNT OF INCREASE

TO EXPLANATION AND SIGNATURE

Explanation

Explanation to reclassify budget to proper accounts.

Reallocation of funds to the appropriate account for Tom Green & Company Engineers for Commissioning Services related to the Road and Bridge remodel. Contract was approved by Commissioners Court on November 11, 2024.

File and Documentation

File Upload

Upload

Budget Amendment Request – Commissioning Services (R&B Shop).pdf 157.88KB
Fully Executed Proposal (4).pdf 238.06KB

Signature

Initiator

Nina Payne

Department (?)

BUDGET OFFICE

Signature

Elected Official/Dept Head

Nina Payne

Comments

Elected Official/Dept Head Comments

Signature

Budget Officer Signature

Spencer A Mayst

Budget Officer Comments

CC Approval Oracle Posted

Sign

Completion Date

Date will be captured on form submission

Comments

Commissioners Court Decision Comments

**Tom Green & Company
Engineers, Inc.**

October 30, 2024

PN 124147B
CONFIDENTIAL

Trevor Lansdown
Brazos County
200 S Texas Ave
Bryan, TX 77803

SUBJECT: Commissioning Services RFQ No. 24-135 – Brazos County Road & Bridge Building Remodels: Proposal for Commissioning Services

Trevor:

We appreciate this opportunity to present our proposal for commissioning (Cx) services for the subject project. We look forward to serving you with timely and quality services.

As I understand the project, it involves remodeling of two separate buildings: the office building and the shop building. The project is understood to have completed design and is currently in the bid/solicitation stage for the general contractor. It is our understanding that the office building remodel includes a renovation of the building envelope and does not include mechanical work. The shop building is understood to include renovation of the building envelope and upgrades to the mechanical systems.

Cx Services Description

To better define the expected Cx scope, I offer the following outline of Cx Services that will be provided. The depth at which certain tasks are performed will be adapted based on specific project needs in accordance with the project budget. Other tasks may be added or removed from scope based on project specific needs and confirmation from the Owner.

Pre-Construction Phase Cx Services

- Review of design documents issued for construction for compliance with general code requirements (primarily related to mechanical systems and building envelope) and engineering fundamentals. The focus of the review shall be for the purpose of general constructability, functionality, and maintainability of the systems.
- Meeting with the Owner for confirmation of critical design elements with Owner's needs and standards.
- Review design specifications for appropriate of Cx obligations and provide supplemental Cx specifications/obligations if/as necessary.
- Providing Cx review logs to the A/E team noting findings from review of design documents to be incorporated into revisions by the design team if/as necessary.
- Review of A/E responses to Cx log items and confirmation that items were addressed by the A/E team appropriately.

Brazos County Road & Bridge Building Remodels: Proposal for Cx Services

Bid/Solicitation Phase Cx Services

- Review Contractor qualifications, bids, and/or CMR's Guaranteed Maximum Prices (GMPs), as applicable for the project delivery type.
- Review inclusions/exclusions and clarifications of bids against Contract Documents in coordination with the A/E team.

Construction Phase Cx Services

- Review of pertinent construction documentation, including major equipment submittals, envelope construction submittals, Requests for Information (RFIs), and Contractor's Pay Applications.
- Review of addendums, revisions, Architects Supplemental Instructions (ASIs), etc., released during construction.
- Lead pre-Cx planning meeting(s) with project stakeholders (construction team, design team, Owner representatives, and others as applicable).
- Develop a Cx plan for the construction process to be incorporated into the Contractor's construction schedule, including pre-functional performance checklists (PFPCs), functional performance tests (FPTs), and an integrated systems test (IST). The level of detail and format of the PFPCs, FPTs, and IST will vary depending on the type/size of the project and overall project goals/needs.
- Attend construction progress meetings. In general, the CxA's attendance will be virtual, unless in-person attendance is beneficial to the project or if the CxA is already onsite for other Cx activities. Meeting minutes/records to be created and distributed by parties other than TGCE (unless otherwise agreed upon with Brazos County).
- Perform progress site visits to the project at critical points during the construction process to review installations and mockups, witness pertinent systems testing and equipment startups where determined to be important by the CxA or Owner, review contractor's pre-functional checks, and witness functional testing.
- Create, manage, and issue Cx deficiency logs based on observations made during the CxA's site visits, PFPCs, FPTs, and IST.
- Develop and issue a Cx report detailing the Cx activities performed, their outcomes, and any remaining work (if applicable) not completed through the Cx process.

Project Close-Out and Warranty Phase Cx Services

- Review close-out documentation provided by the A/E and Construction teams (e.g., as-builts, record drawings/specifications, record submittals, O&M manuals, etc.) and confirm that all documents required by the OPRs/CFRs and Contract Documents are provided.
- Perform warranty site visits to observe site conditions at stages throughout the warranty period as requested by the Owner.
- Confirm that the contractor provides all required Owner training.
- If necessary and appropriate, select system testing will be performed in specific seasons where such tests could not be performed in the season of original testing.

Understanding of Proposal Exclusions:

It is understood that the following items are currently not requested, not applicable, or not expected to be needed by this team. To the extent scope is determined to be otherwise as the project evolves, additional scope can be performed by the CxA with confirmation by the Owner.

- Design reviews and other Cx activities will generally be limited to MEP, fire alarm (FA), fire protection (FP), and building envelope systems. All other trades are not currently

Brazos County Road & Bridge Building Remodels: Proposal for Cx Services

included in the Cx scope, except where such scopes are understood to impact MEP, FA, FP, and building envelope systems. To the extent that they are deemed to be necessary for the respective project scope, TGCE will engage those services for inclusion in Cx services.

- Design milestone and other reviews will generally not include the CxA performing cooling/heating load calculations, hygrothermal analysis, or other detailed calculations/analysis.
- Permitting for the project is understood to be the responsibility of the Construction team/Contractor.
- Opinions of Probable Construction Costs (OPCCs) are to be provided by parties other than the CxA (e.g., the CMR).
- Testing, Adjusting, and Balancing (TAB) is to be procured by the Contractor or the Owner, depending on specific project requirements. TAB is not included under TGCE's contract. TGCE will support the TAB process as applicable to Cx services and as requested by the Owner.

Cx Services Fee

We believe an hourly fee budget approach best fits the potentially varying level of effort required for these Cx services. Effort will be billed against the contracted fee on an hourly personnel cost expended in each billing period. This approach provides both an upper-limit protection for the Owner as well as the assurance that the Owner receives the benefit of all economies we experience.

We have estimated our level of effort for this project to be \$145,000 and propose that estimate as the fee budget.

It is understood that hourly fee budgets may not be sufficient to complete all the necessary work for the project. As we approach the fee budget amount, TGCE so advises you to review the status of the project and expectations for further direction of work to mutually determine if an extension of the budget is appropriate or if we should pause our services upon reaching the budget. This review is to occur through our monthly invoicing for work performed for the prior work period, with direction by the Owner if it anticipates expansion of budget or restriction of work.

The required level of effort for each project is influenced by a number of factors, such as project complexity, project delivery method, project design team, project construction team, and procurement issues (e.g., long lead times, etc.) or other economic factors that impact project schedule. Some of these factors are outside of the CxA's control, but the CxA is committed to adapting their services to meet the varying needs of the project as the various project factors impact them as can reasonably be accomplished within the agreed-upon fee budgets. Where such factors are expected to limit the work that can be accomplished within the agreed-upon fee budget, TGCE will notify the Owner of such and receive direction from the Owner on how to proceed.

For reference, WJE's proposal for the building envelope commissioning services is attached. The fee budget presented in their proposal is included in the total fee budget indicated above.

Additional Services

Given the hourly budget approach to the project, additional services are not applicable, as all hourly efforts are invoiced.

Brazos County Road & Bridge Building Remodels: Proposal for Cx Services

Invoicing

Invoicing will be monthly with the net due in thirty (30) days, consistent with the Master Contract.

Ours and our subconsultant's normal hourly rates which apply to our services can be found attached. (These rates are subject to annual adjustments in accordance with our standard salary review practices.)

Reimbursables are in addition to labor charges. Reimbursables include costs of out-of-town travel (mileage at active IRS rates).

Acceptance

If this proposal is acceptable to you, please provide an approval consistent with your normal procedures. Should there be any questions or requested changes, please contact me to go over them at your earliest opportunity.

We appreciate this opportunity to serve you and the Owner, and look forward to a successful project!

Sincerely,

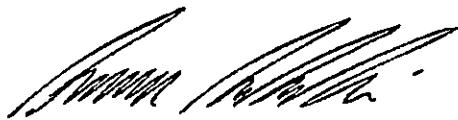

Cameron Labunski, P.E.
Principal Engineer

Texas Firm Registration No. 2929

CL:wh

APPROVED



Duane Peters
County Judge

Date

Tom Green & Company Engineers, Inc.

MEP Hourly Rates, Effective March, 2024

<u>Designation</u>	<u>Rate per Hour</u>
Principal Engineer,	\$340
Senior Engineer,	\$295
Staff Engineer,	\$260
Engineer,	\$230
Senior Designer,	\$215
Staff Designer,	\$195
Engineer-in-training,	\$170
Designer,	\$160
Tech Staff,	\$150
Administrator,	\$145
Clerical,	\$95

Licensed Engineers

<u>Principal Engineer</u>	<u>TX License No.</u>
Tom Green	51655
Tod Thompson	75752
Cameron Labunski	92707

<u>Senior Engineer</u>	
Sam Hammer	57683
Ruth Sulzer	97586
Jennifer Hall	104958
John A. Marsac	114415

<u>Staff Engineer</u>	
Yinling Ng	139459

<u>Engineer</u>	
Alvaro Gloria	141147
Wyatt Hahn	144591
Miguel Minick	148855

These rates are subject to annual adjustment in accordance with our standard salary review practices, and will be adjusted as such for invoicing.



BRAZOS COUNTY
REQUEST FOR BUDGET AMENDMENT

Budget
Amendment
Number *

Budget Amendment Number

19.07

Agenda Date

6/23/2026

Fiscal Year

October 1 - September 30 2026

Requesting Department

JUVENILE SERVICES

Requestors Name

Ted Randall

DECREASE EXPENDITURE(S):

1000 General Fund

From: Fund Number

DECREASE EXPENDITURE(S):

31000006 Juvenile Services - Nc

From: Division Name

DECREASE EXPENDITURE(S):

65052000 Carpentry & Building I

From: Account Number

From: Amount

\$

1,850.00

AMOUNT OF DECREASE

Total

\$ 1,850.00

TOTAL AMOUNT OF DECREASE

INCREASE EXPENDITURE(S):

1000 General Fund

To: Fund Number

INCREASE EXPENDITURE(S):

31000110 Juvenile Services - Ad

To: Division Name

INCREASE EXPENDITURE(S):

61740000 Telephone

To: Account Number

To: Amount

\$

1,850.00

AMOUNT OF INCREASE

Total

\$ 1,850.00

TOTAL AMOUNT OF INCREASE

TO EXPLANATION AND SIGNATURE

Explanation

Explanation to reclassify budget to proper accounts:

Requesting move per auditor to cover shortage of funds for the telephone bill.

File and Documentation

File Upload

Upload

Signature

Initiator

Fed Randall

Department (?)

JUVENILE SERVICES

Signature

Elected Official/Dept Head

Linda Picketson

Comments

Elected Official/Dept Head Comments

Signature

Budget Officer Signature

Spencer A Mays

Budget Officer Comments

CC Approval Oracle Posted

Sign

Completion Date

Date will be captured on form submission

Comments

Commissioners Court Decision Comments

**BRAZOS COUNTY, TEXAS
BUDGET AMENDMENTS
No. 25/26 - 19.08
6/23/2026**

FUND NAME	DEPARTMENT NAME	CLASS DESCRIPTION	ACCOUNT CATEGORY	INCREASE	DECREASE
2026 General Obligation Bonds		Other Financing Sources	Revenue	6,760,000.00	
2026 General Obligation Bonds		Other Financing Sources	Revenue	382,242.90	
2026 Certificates of Obligation		Other Financing Sources	Revenue	36,175,000.00	
2026 Certificates of Obligation		Other Financing Sources	Revenue	2,210,768.55	
2026 General Obligation Bonds	Bush/Wellborn	Contractual Services	Expenditure	7,070,895.50	
2026 General Obligation Bonds	Bush/Wellborn	Debt Service	Expenditure	71,347.40	
2026 Certificates of Obligation	County Administration Building	Capital Outlay	Expenditure	13,087,120.00	
2026 Certificates of Obligation	County Administration Building	Debt Service	Expenditure	57,195.81	
2026 Certificates of Obligation	101 North	Capital Outlay	Expenditure	25,166,428.66	
2026 Certificates of Obligation	101 North	Debt Service	Expenditure	75,024.08	

2026 General Obligation Bonds & 2026 Certificates of Obligation

To recognize the revenue issuance of the new General Obligation Bonds, Series 2026 and Certificates of Obligation, Series 2026.
To recognize the corresponding expenses these new revenues will be used for

Date: SAM
6/11/2026

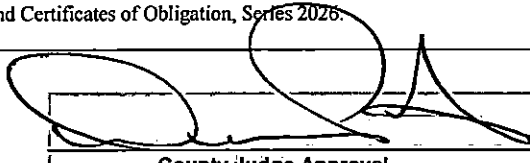
 County Judge Approval 6/23/26
Date

For Oracle Entry Only				
FUND	DIV	ACCT	Change In Budget	ACCOUNT NAME
43260	00000000	49092000	6,760,000.00	
43260	00000000	49095000	382,242.90	
43261	00000000	49090000	36,175,000.00	
43261	00000000	49095000	2,210,768.55	
43260	63432308	71025000	7,070,895.50	
43260	63432308	85500000	71,347.40	
43261	63270000	80101000	13,087,120.00	
43261	63270000	85500000	57,195.81	
43261	63432322	80100000	25,166,428.66	
43261	63432322	85500000	75,024.08	

**BRAZOS COUNTY, TEXAS
REQUEST FOR BUDGET AMENDMENT TO INCREASE BUDGET**

REQUESTING DEPARTMENT _____

Auditor _____

REVENUE BUDGET

FY 2026

FUND	DIVISION	ACCOUNT	ACCOUNT DESCRIPTION	DOLLAR AMOUNT
43260	00000000	49092000	Proceeds from GO Bond Issue	6,760,000.00
43260	00000000	49095000	Bond Issue Premium	382,242.90
43261	00000000	49090000	Proceeds from CO Bond Issue	36,175,000.00
43261	00000000	49095000	Bond Issue Premium	2,210,768.55
TOTAL REVENUES				\$ 45,528,011.45

EXPENSE BUDGET

FUND	DIVISION	ACCOUNT	ACCOUNT DESCRIPTION	DOLLAR AMOUNT
43260	63432308	71025000	Contract Services	7,070,895.50
43260	63432308	85500000	Bond Issuance Cost	71,347.40
43261	63270000	80101000	Building Improvements	13,087,120.00
43261	63270000	85500000	Bond Issuance Cost	57,195.81
43261	63432322	80100000	Buildings	25,166,428.66
43261	63432322	85500000	Bond Issuance Cost	75,024.08
TOTAL EXPENSES				\$ 45,528,011.45

SELECT REASON FOR EXCEPTION TO INCREASE BUDGET FROM BELOW (click in box to select)

- Debt
- Grant
- Unanticipated Revenue
- Emergency
- Donation

EXPLANATION

To recognize the revenue on issuance of the new General Obligation Bonds, Series 2026 and Certificates of Obligation, Series 2026. To recognize the corresponding expenses these new revenues will be used for.

ELECTED OFFICIAL OR DEPARTMENT HEAD SIGNATURE

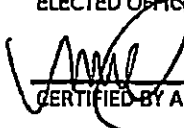
CERTIFIED BY AUDITOR

DATE

6/12/26
DATE

**BRAZOS COUNTY, TEXAS
BUDGET AMENDMENTS
No. 25/26 - 19.09
6/23/2026**

FUND NAME	DEPARTMENT NAME	CLASS DESCRIPTION	ACCOUNT CATEGORY	INCREASE	DECREASE
2023 Certificates of Obligation	101 North	Capital Outlay	Expenditure		58,822,230.55
2023 Certificates of Obligation		Other Financing Sources	Revenue		58,822,230.55
General Fund		Other Financing Uses	Expenditure		58,822,230.55
General Fund	Contingency	Contingency	Expenditure	58,822,230.55	
Capital Improvement Fund	County Administration Building	Capital Outlay	Expenditure		13,087,120.00
Capital Improvement Fund		Other Financing Sources	Revenue		13,087,120.00
General Fund		Other Financing Uses	Expenditure		13,087,120.00
General Fund	Contingency	Contingency	Expenditure	13,087,120.00	
General Fund	Contingency	Contingency	Expenditure		35,030,449.58
General Fund		Other Financing Uses	Expenditure	35,030,449.58	
2026 Certificates of Obligation		Other Financing Sources	Revenue	35,030,449.58	
2026 Certificates of Obligation	101 North	Supplies and Other Charges	Expenditure	19,875.00	
2026 Certificates of Obligation	101 North	Capital Outlay	Expenditure	35,010,574.58	

2023 Certificates of Obligation, 2026 Certificates of Obligation, Capital Improvement Fund and General Fund

Reallocation of funds to the appropriate account to close out prior debt funds and move current projects to the new debt.

Date: SAM
6/11/2026

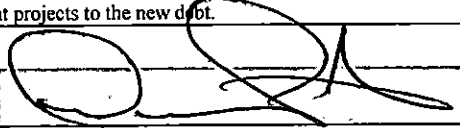

 County Judge Approval 6/23/26
Date

For Oracle Entry Only					
FUND	DIV	ACCT	Change in Budget	ACCOUNT NAME	
43232	63432322	80100000	(58,822,230.55)		
43232	00000000	49028000	(58,822,230.55)		
01000	00000000	91123000	(58,822,230.55)		
01000	11001500	61130000	58,822,230.55		
45000	63270000	80101000	(13,087,120.00)		
45000	00000000	49028000	(13,087,120.00)		
01000	00000000	91110000	(13,087,120.00)		
01000	11001500	61130000	13,087,120.00		
01000	11001500	61130000	(35,030,449.58)		
01000	00000000	91124000	35,030,449.58		
43261	00000000	49028000	35,030,449.58		
43261	63432322	61010000	19,875.00		
43261	63432322	80100000	35,010,574.58		

43232 - CO 2023

		Budgeted	Actual	Variance
Fund Balance	47010000	9,060,487.00	8,454,577.00	605,910.00
Transfer From General Fund	49028000	60,040,000.00	59,000,000.00	1,040,000.00
FY26 Actual Revenues	45*	377,000.00	199,423.00	177,577.00
		<u>69,477,487.00</u>	<u>67,654,000.00</u>	<u>1,823,487.00</u>
FY26 Actual Expenditures	80*	64,580,800.56	3,935,083.01	60,645,717.55
Transfer to General Fund (Reimburse Prior Year allowable bond expenditures	91300000	4,896,686.44	4,896,686.44	-
		<u>69,477,487.00</u>	<u>8,831,769.45</u>	<u>60,645,717.55</u>

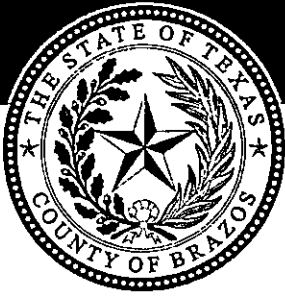
58,822,230.55	(58,822,230.55)
174,057.59	Amt spent over the debt funds
<u>58,996,288.14</u>	Total
<u>59,000,000.00</u>	Amt Trfd In
<u>(3,711.86)</u>	Difference
<u>3,712.17</u>	May Interest not posted at 6.11.26
<u>0.31</u>	



BRAZOS COUNTY
REQUEST FOR BUDGET AMENDMENT

**Budget
Amendment
Number***

Budget Amendment Number

Agenda Date

Fiscal Year

Requesting Department

Requestors Name

DECREASE EXPENDITURE(S):	DECREASE EXPENDITURE(S):	DECREASE EXPENDITURE(S):	From: Amount
<input type="text" value="13000 Unclaimed Property Fund"/>	<input type="text" value="12005000 Unclaimed Property F"/>	<input type="text" value="61130000 Contingency"/>	<input type="text" value="\$ 123,573.81"/>
From: Fund Number	From: Division Name	From: Account Number	AMOUNT OF DECREASE

Total
TOTAL AMOUNT OF DECREASE

INCREASE EXPENDITURE(S):	INCREASE EXPENDITURE(S):	INCREASE EXPENDITURE(S):	To: Amount
<input type="text" value="1000 General Fund"/>	<input type="text" value="11001500 Contingency"/>	<input type="text" value="61130000 Contingency"/>	<input type="text" value="\$ 123,573.81"/>
To: Fund Number	To: Division Name	To: Account Number	AMOUNT OF INCREASE

Total
TOTAL AMOUNT OF INCREASE

TO EXPLANATION AND SIGNATURE

Explanation

File and Documentation

File Upload

Upload

Budget Amendment Request Unclaimed Property Fund 6.12.2026.pdf

227.77KB

Signature

Initiator

Arena Payne

Department (?)

BUDGET OFFICE

Signature

Elected Official/Dept Head

Arena Payne

Comments

Elected Official/Dept Head Comments

Signature

Budget Officer Signature

Spencer A. Mays

Budget Officer Comments

CC Approval Oracle Posted

Sign

Completion Date

Date will be captured on form submission

Comments

Commissioners Court Decision Comments



Office of the Brazos County Treasurer

Brazos County Administration Building
200 S Texas Ave., Suite 240
Bryan, TX 77803

Cristian T. Villarreal
County Treasurer

Tel (979) 361-4340
Fax (979) 361-4347
CVillarreal@brazoscountytexas.gov

DATE: June 12, 2026

TO: Nina Payne, Budget Officer

FROM: Cristian Villarreal, Brazos County Treasurer

RE: Budget Amendment Request Unclaimed Property Fund

I am requesting a budget amendment to allow interest earned from previous fiscal years in the Unclaimed Property Fund (13000) to be moved to the General Fund (01000).

13000-12005000-61130000 – Decrease \$123,573.81

13000-00000000-91300000 – Increase \$123,573.81



**BRAZOS COUNTY
BRYAN, TEXAS**

DEPARTMENT: Purchasing

NUMBER:

DATE OF COURT MEETING: 6/23/2026

ITEM: Permission to Advertise Bid #27-007 Cutback Asphalt.

TO: Commissioners Court

FROM: Celina Nava

DATE: 06/02/2026

FISCAL IMPACT: False

BUDGETED: False

DOLLAR AMOUNT: \$0.00

NOTES/EXCEPTIONS:

Road and Bridge Department is requesting a contract for cutback asphalt services. Brazos County use cutback asphalt for road maintenance because it liquefies without needing constant high-temperature heating. This provides critical operational and financial advantages, making it especially practical for rural networks, patching operations, and cold-weather construction where heating equipment is unavailable.

ATTACHMENTS:

File Name

[Request to Advertise 27-007.pdf](#)

Description

Permission to Advertise

Type

Backup Material



Brazos County Purchasing Department

200 S. TX AVE., SUITE 352 BRYAN, TX 77803
PHONE (979) 361-4290 FAX (979) 361-4293

BRAZOS COUNTY BID DOCUMENTATION SHEET

The Purchasing Department would like to request Commissioner's Court approval to advertise and solicit Bids for the following:

DATE: June 23, 2026

BID NUMBER: 27-007

TITLE: Cutback Asphalt

REQUESTING DEPARTMENT: Road and Bridge

APPROVAL SIGNATURE: _____

A handwritten signature in black ink, appearing to be "W. J. ...", is written over a horizontal line.

County Judge

DATE APPROVED: _____

The date "June 23, 2026" is handwritten in black ink over a horizontal line.



**BRAZOS COUNTY
BRYAN, TEXAS**

DEPARTMENT: Purchasing NUMBER:

DATE OF COURT MEETING: 6/23/2026

ITEM: Approval of the following Deductive Change Orders to CIP #25-583 Brazos County Scour Repair with Solid Bridge Construction, totaling \$41,435.

- a. Harris Lane (002) - (\$15,000.00)
- b. Fickey Road - North (001) - (\$26,435.00)

TO: Commissioners Court

FROM: Celina Nava

DATE: 06/02/2026

FISCAL IMPACT: False

BUDGETED: False

DOLLAR AMOUNT: \$0.00

NOTES/EXCEPTIONS: These deductive change orders will remove unused line items and remaining contingency from each project. The final project total are as follows:

- Harris Lane (002) \$314,606.00.
- Fickey Road North (001) \$408,168.00

ATTACHMENTS:

<u>File Name</u>	<u>Description</u>	<u>Type</u>
Deductive Change Order- Harris Lane.pdf	Deductive Change order for Harris Lane	Backup Material
Deductive Change Order Fickey Road 06022026.pdf	Deductive Change Order Fickey Road North	Backup Material
Fully Executed Contract - Solid Bridge Construction.pdf	Original Contract	Backup Material

CHANGE ORDER #1

Date of Issuance: 5/29/2026
 Owner: Brazos County Road & Bridge Owner's Contract No.: CIP 25-583
 Contractor: Solid Bridge Construction Engineer's Project No.: 619044
 Project: Harris Lane Bridge Scour

The Contract is modified as follows upon execution of this Change Order:
 Description: Deductive change order removing unused line items from the project.

Bid Item No.	Description	Quantity	Bid Unit	Bid Price	Total
417	Contingency	-1	LS	\$15,000.00	-\$15,000.00
Change Order Total Decrease:					-\$15,000.00

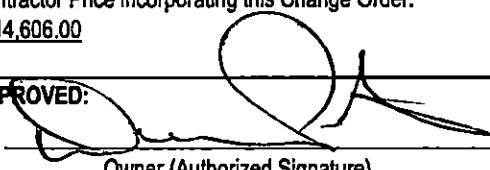
CHANGE IN CONTRACT PRICE	CHANGE IN CONTRACT ITEMS FOR HARRIS LANE
Original Contract Price: <u>\$329,606.00</u>	Original Contract Times: <u>30 Days</u> Substantial Completion: <u>05/20/2026</u> Ready for Final Payment: <u>06/19/2026</u>
Change from previously approved Change Order : <u>N/A</u> <u>\$0.00</u>	Change from previously approved Change Orders : <u>0 days</u> Substantial Completion: <u>05/20/2026</u> Ready for Final Payment: <u>06/19/2026</u>
Contract Price prior to this Change Order: <u>\$329,606.00</u>	Contract Times prior to this Change Order: <u>7 days</u> Substantial Completion: <u>05/27/2026</u> Ready for Final Payment: <u>06/26/2026</u>
Decrease of this Change Order: <u>-\$15,000.00</u>	Change of this Change Order: Days: <u>0 days</u> Substantial Completion: <u>05/27/2026</u> Ready for Final Payment: <u>06/26/2026</u>
Contractor Price incorporating this Change Order: <u>\$314,606.00</u>	Contract Times with all approved Change Orders: Substantial Completion: <u>05/27/2026</u> Ready for Final Payment: <u>06/26/2026</u>
APPROVED: By:  Owner (Authorized Signature)	ACCEPTED: By: <u>Travis J Hanus</u> Contractor (Authorized Signature)
Title: <u>County Judge</u>	Title: <u>Vice President</u>
Date: <u>6/23/26</u>	Date: <u>6/1/2026</u>

RECOMMENDED: Mason Kwiatkowski
 By: _____
 Title: Mason Kwiatkowski PE

Date: 5/29/2026



6/2/26

CHANGE ORDER #1

Date of Issuance: 6/2/2026	Owner's Contract No.: CIP 25-583
Owner: Brazos County Road & Bridge	Engineer's Project No.: 619052
Contractor: Solid Bridge Construction	
Project: Fickey Road (North) Bridge Scour	

The Contract is modified as follows upon execution of this Change Order:
 Description: Deductive change order removing unused line items from the project.

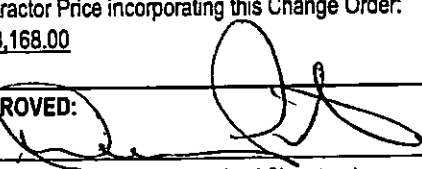
Bid Item No.	Description	Quantity	Bid Unit	Bid Price	Total
814	6" concrete slope paving, including cement sand, related items and appurtenances, complete in place	-25	SY	\$170.00	-\$4,250.00
819	4" Thick Concrete Mow Strip (Guardrail), (GF(31)MS-19), including related items and appurtenances, complete in place	-19	SY	\$115.00	-\$2,185.00
821	Contingency	-1	LS	\$20,000.00	-\$20,000.00
Change Order Total Decrease					-\$26,435.00

CHANGE IN CONTRACT PRICE	CHANGE IN CONTRACT ITEMS FOR FICKEY ROAD (NORTH)
Original Contract Price: <u>\$434,603.00</u>	Original Contract Times: <u>78 Days</u> Substantial Completion: <u>6/16/2026</u> Ready for Final Payment: <u>7/16/2026</u>
Change from previously approved Change Order : <u>N/A</u> <u>\$0.00</u>	Change from previously approved Change Orders : <u>0 days</u> Substantial Completion: <u>6/16/2026</u> Ready for Final Payment: <u>7/16/2026</u>
Contract Price prior to this Change Order: <u>\$434,603.00</u>	Contract Times prior to this Change Order: <u>11 days</u> Substantial Completion: <u>06/27/2026</u> Ready for Final Payment: <u>07/27/2026</u>
Decrease of this Change Order: <u>-\$26,435.00</u>	Change of this Change Order: Days: <u>-38 days</u> Substantial Completion: <u>05/20/2026</u> Ready for Final Payment: <u>06/19/2026</u>
Contractor Price incorporating this Change Order: <u>\$408,168.00</u>	Contract Times with all approved Change Orders: Substantial Completion: <u>05/27/2026</u> Ready for Final Payment: <u>06/26/2026</u>
APPROVED: By:  Owner (Authorized Signature) Title: <u>County Judge</u> Date: <u>6/23/26</u>	ACCEPTED: By:  Contractor (Authorized Signature) Title: <u>Travis Hanus - Vice President</u> Date: <u>6/3/2026</u>

RECOMMENDED: 
 By: _____
 Title: Mason Kwiatkowski PE

Date: 6/2/2026

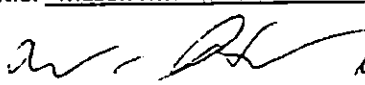
 6/3/26

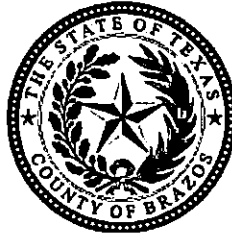

**BRAZOS COUNTY
BRYAN, TEXAS**

DEPARTMENT: Purchasing NUMBER:
DATE OF COURT MEETING: 9/23/2025
ITEM: Award of RFP #CIP 25-583 Brazos County Bridge Scour Repair. Recommended Award:
Solid Bridge Construction, LLC.
TO: Commissioners Court
FROM: Kaitlyn Battles
DATE: 09/12/2025
FISCAL IMPACT: True
BUDGETED: True
DOLLAR AMOUNT: \$3,568,764.00

NOTES/EXCEPTIONS:

The evaluation committee is requesting the award of this project to Solid Bridge Construction, LLC. as the highest evaluated vendor. This project includes improvements at nine individual bridge sites located across the county which have experienced erosion and scour damage from flowing water, putting the structural integrity of each at risk. Repairs will include erosion and sediment control, slope paving and riprap protection, earthwork to reestablish design grades, concrete bridge approaches, replacement of bridge and guard rails to meet TxDOT standards, and site restoration through hydromulching. Temporary traffic control and stormwater pollution retention measures will be included at each location. These repairs are necessary to ensure the safety, functionality, and longevity of critical bridge infrastructure across Brazos County.

ATTACHMENTS:

<u>File Name</u>	<u>Description</u>	<u>Type</u>
<u>Partly Executed Contract - Solid Bridge Construction.pdf</u>	Contract	Backup Material
<u>RFP - Solid Bridge Construction.pdf</u>	RFP	Backup Material
<u>Tabulation.pdf</u>	Tabulation	Backup Material

**AGREEMENT
FOR BRAZOS COUNTY BRIDGE SCOUR
REPAIR**

RFP # CIP 25-583

BRAZOS COUNTY, TEXAS

TABLE OF ARTICLES

1. General Provisions
2. Owner
3. Contractor
4. Administration of the Contract
5. Subcontractors
6. Construction by Owner or by Separate Contractors
7. Changes in the Work
8. Time
9. Payments and Completion
10. Protection of Persons and Property
11. Insurance and Bonds
12. Uncovering and Correction of Work
13. Miscellaneous Provisions
14. Termination or Suspension of the Contract
15. Access to the Work
16. Standards
17. Prohibition against personal interest in the Contract
18. Prevailing Wage Rates
19. Authority to Contract

AGREEMENT FOR CONSTRUCTION OF BRAZOS COUNTY
ROADWAY

This Agreement for the construction of the BRAZOS COUNTY BRIDGE SCOUR Brazos County, Texas, in the amount of **THREE MILLION, FIVE HUNDRED AND SIXTY EIGHT THOUSAND, SEVEN HUNDRED AND SIXTY FOUR DOLLARS (\$3,568,764.00)** is entered into this ____ day of September 2025 by and between **BRAZOS COUNTY, TEXAS** (hereafter referred to as "Owner"), 200 South Texas Ave., Suite 352, Bryan, Texas 77803, and **SOLID BRIDGE CONSTRUCTION, LLC.**, (hereinafter referred to as "Contractor"). The BRAZOS COUNTY BRIDGE SCOUR RECONSTRUCTION is hereinafter referred to as the "Project." The Engineer for the Project is the firm of **GOODWIN-LASSITER-STRONG** and is hereinafter referred to as "Engineer."

**ARTICLE 1
GENERAL PROVISIONS**

1.1. BASIC DEFINITIONS

1.1.1 THE COMPLETE CONTRACT DOCUMENTS: The complete Contract Documents ("Contract Documents") consist of the Agreement between Owner and Contractor (hereinafter the "Agreement"), Conditions of the Contract (General, Supplementary and other Conditions), all documents included in **RFP # CIP 25-583** and the Drawings, Project Manual and Bid Specifications, as well as Addenda issued prior to execution of the Contract, other documents listed in the Agreement and Modifications issued after execution of the Contract.

A Modification is: (1) a written amendment to the Contract signed by both parties; (2) a Change Order or Change Proposal Request; (3) a Construction Change Directive, or (4) a clarification, interpretation or written order for a minor change in the Work issued by the Engineer. Unless specifically enumerated in the Agreement, the Contract Documents do not include other documents such as bidding requirements (advertisement or invitation to bid, Instructions to Bidders, sample forms or portions of addenda relating to bidding requirements). The Contract Documents executed in accordance with Sub-paragraph 1.5.1. shall prevail in case of an inconsistency with subsequent versions made through manipulatable electronic operations involving computers.

1.1.2 THE CONTRACT: The Contract Documents form the Contract for Construction ("Contract"). The Contract represents the entire and integrated agreement between the parties hereto and supersedes prior negotiations, representations or agreements, either written or oral. The Contract may be amended or modified only by a Modification. The Contract Documents shall not be construed to create a contractual relationship of any kind: (1) between the Contractor and Engineer or Engineer's consultants; (2) between the Owner and a Subcontractor or Sub-subcontractor, or (3) between any persons or entities other than the Owner and Contractor. The Engineer shall, however, with the consent of Owner, be entitled to performance and enforcement of obligations under the Contract intended to facilitate performance of the Engineer's duties.

1.1.3 THE WORK: The term "Work" means the construction and services required by the Contract, whether completed or partially completed, and includes all other labor,

materials, equipment and services provided or to be provided by the Contractor to fulfill the Contractor's obligations. The Work may constitute the whole or a part of the Project. Although not indicated, "Work" includes providing supplementary or miscellaneous items, appurtenances and devices incidental to or necessary for a sound, secure, complete and functional installation.

1.1.4 THE PROJECT: The Project is the rehabilitation of the **2025 Bridge Scour Repair** in Brazos County, Texas that consists of 9 individual projects that vary in locations as specified in the Contract Documents. The Project may include construction by the Owner or by separate contractors.

1.1.4.1 SUMMARY OF THE WORK: This project consists of 9 Bridge Scour Repair projects, which include, Alexandar Road (002), Alexandar Road (003), Collette Lane, Harris Lane, Dilly Shaw Tap Road, Kurten Cemetery Road, Fickey Road (001), Fickey Road (002), and Deep Well Road.

1.1.5 THE DRAWINGS: The Drawings are the graphic and pictorial portions of the Contract Documents, wherever located and whenever issued, showing the design, location and dimensions of the Work, generally including plans, elevations, sections, details, schedules and diagrams.

1.1.6 THE SPECIFICATIONS: The Specifications are that portion of the Contract Documents consisting of the written requirements for materials, equipment, construction systems, standards and workmanship for the Work, and performance of related services.

1.1.7 THE PROJECT MANUAL: The Project Manual is the volume usually assembled for the Work that may include the bidding requirements, sample forms, this Agreement, Supplementary Conditions of the Contract and Specifications.

1.1.8 GENERAL DEFINITIONS: Construction industry technical terms not defined in the Contract Documents shall have the meanings given as listed in the latest edition of the AIA "Glossary of Construction Industry Terms." Those not specifically defined at either place shall have the meanings commonly attributed to them by the particular trade involved.

1.1.8.1 Provide: shall be understood to mean: "Furnishing of all labor, materials, equipment, transportation and services referred to and installation of the materials, equipment and other items referred to, all in compliance with the requirement of the Contract Documents and applicable Federal, State and local laws and ordinances as well as requirements of Federal, State and local authorities having jurisdiction at the site of the Work."

1.1.8.2 Required: shall be understood to refer to the requirements of the contract Documents unless its use in a sentence clearly implies a different interpretation.

1.1.8.3 Where "as shown," "as indicated," "as noted," and similar terms are used, it shall be understood that reference to the Contract Drawings is made, unless their use in a sentence clearly implies a different interpretation.

1.1.8.4 Where the terms "Plans" or "Drawings" are used, they shall be understood to

include drawings, details and schedules as applicable.

1.1.8.5 Construction Time: the number of calendar days required to perform the work. Refer to Sections 8.1.1 and 8.1.2.

1.1.8.6 Day: A calendar day beginning and ending at 12:00 midnight.

1.1.8.7 Equal; approved equal; Engineer approved; acceptable; approved; satisfactory; required; directed; instructed: Such terms and related phrases shall relate to the opinions and interpretations of the Contract Documents by the Engineer, unless otherwise stated, and shall be limited in authority and responsibility as defined under this Agreement and the contract between the Engineer and Owner.

1.1.8.8 Date of Final Completion: The date when Engineer and Owner find all the work of the Contract documents acceptable and the Contract fully performed.

1.1.8.9 Occurrence: Is defined as follows for purpose of insurance – An event which occurs during the policy period, or a continuous or repeated exposure to conditions which result, during the policy period in bodily injury, sickness or disease, or injury to or destruction of property, excluding injuries or deaths of one or more persons or organizations, including the loss of use thereof, resulting from a common cause or from exposure to substantially the same general condition existing at or emanating from each location shall be deemed to result from one occurrence.

1.1.8.10 Not-In-Contract (N.I.C.): Work not included in this Contract.

1.1.8.11 And/or: Shall mean both "and" and "or" and shall be enforceable by Owner when read in either manner.

1.1.8.12 General Contractor: Same as Contractor.

1.1.8.13 Material Man; Material Supplier: Anyone that supplies material only and does not perform any labor at the site of the work.

1.1.8.14 Timely Change: A change in the work that can be arranged before the particular item of work has required the expenditure of any non-recoverable costs by the Contractor and/or subcontractors.

1.1.8.15 Late Change: A change in the work that cannot be performed before the particular item of work that requires the expenditure of some non-recoverable cost after shop drawings, samples and/or schedules related to the change have been reviewed and found acceptable.

1.1.8.16 Prompt: Promptly and similar terms shall be held to refer to a time period of not less one week or more than two weeks.

1.1.8.17 Addendum: A change to the Construction Documents (General Documents, Specifications and Drawings) issued prior to the execution of the Agreement.

1.1.8.18 Agreement/Contract: Agreement/Contract means the same and are used

interchangeably throughout this document. This Agreement/Contract is the signed agreement between Owner and Contractor for the performance of the Work.

1.1.8.19 Critical Path: The project's tasks that will cause the project end date to be delayed if they are delayed. The word "critical" does not imply how important a task is; a task is critical solely because it must occur as scheduled for the project to finish on time.

1.1.8.20 Furnish: Unless specifically limited in context, the word "furnish" and any derivatives thereof mean: deliver indicated items, materials, equipment, apparatus, appurtenances and all items necessary for a complete and proper installation to Project site and stored in secure locations.

1.1.8.21 Install: "Install" and any derivatives thereof mean; incorporated indicated items, materials, equipment, apparatus, appurtenances and all items necessary for the Work including all necessary labor, materials and connections to perform a properly and complete installation ready for operation of use, including but not limited to unpacking and assembly, if necessary.

1.1.8.22 The Contractor Shall: In the interest of conciseness; sentences, statements and clauses may be verb phrases with expressed verbs such as "furnish," "install," "provide," "construct," "erect," "comply," "apply," "submit," etc. Any such sentences, statements and clauses are to be interpreted to include the applicable form of the phrase "the Contract shall" preceding the expressed verb, with the requirements described interpreted as mandatory elements of the Contract.

1.1.8.23 Evaluation: "Evaluation" and any derivative thereof, as used in reference to Engineer mean; to become generally familiar with the progress and quality of the portion of Work completed to determine in general if it is being performed in a manner indicating that the Work when completed may be occupied or utilized by the Owner for its intended use. Such evaluations shall be based on what is plainly visible at the construction site during periodic visits to the Project, and without the removal of material or other Work that is in place.

1.1.8.24 Inspect: "Inspect" and any derivative thereof, as used in reference to the Engineer shall mean; Type of evaluation that a reasonably prudent Engineer, in the exercise of ordinary care, would make to determine if the Work is in general accordance with the Contract Documents; they are not "inspections" as would necessarily disclose a defect.

1.1.8.25 See: In the interest of conciseness, references to specification sections and details are preceded by the word "see." Any such references are to be interpreted to include applicable form of phrase "...and comply with."

1.2 CORRELATION AND INTENT OF THE CONTRACT DOCUMENTS

1.2.1. The intent of the Contract Documents is to include all items necessary for the proper execution and completion of the Work by the Contractor. The Contract Documents are complementary and what is required by one shall be as binding as if required by all; performance by the Contractor shall be required only to the extent consistent with the Contract Documents and reasonably inferable from them.

1.2.2. Organization of the Specifications into divisions, sections and articles, and arrangement of Drawings shall not control the Contractor in dividing the Work among Subcontractors or in establishing the extent of Work to be performed, nor limit the scope of work performed by any trade or by any Sub-contractor or supplier.

1.2.3. Unless otherwise stated in the Contract Documents, words which have well-known technical or construction industry meanings are used in the Contract Documents in accordance with such recognized meanings.

1.2.4. General Conditions and Supplementary Condition and General Requirements apply to all of the Contract Documents.

1.2.5 Precedence of the Contract Documents: The most recently issued Document takes precedence over previous issues of the same Document. The order of precedence is as follows with the highest authority listed as "A".

1.2.5.1 Modifications, Change Orders or a Change Proposal Request

1.2.5.2 This Agreement, including the General Conditions stated herein.

1.2.5.3 Addenda

1.2.5.4 Supplementary Conditions

1.2.5.5 Specifications and Drawings. In the case of an inconsistency between Drawing and specifications or within either document, the better quality and the greater quantity of work shall be provided unless otherwise directed by Engineer.

1.2.6 Current Editions: When any work is governed by reference to standard, codes, manufacturer's instructions or other reference documents, the latest issue in effect on the original issue date of the Construction Documents shall apply whether or not the proper edition is noted.

1.2.7 Enumeration of Items: Lists of "work included," "work excluded" and "description of the work" and similar groupings are not intended to enumerate each and every item of work or appurtenance required therein but shall be used in conjunction with all other portions of the Contract Documents to establish the requirements for completion of the Work or any portions thereof.

1.2.8 Reference Guarantees: When reference standards are made a part of the requirements, the warranties and guarantees they contain shall apply, except for the portions that are less stringent than those required by the Contract Documents or imply or state exclusions, limitations or waivers that are inconsistent with the requirements of the Contract Documents.

1.3 CAPITALIZATION

1.3.1 Terms capitalized in these General Conditions include those which are: (1) specifically defined; (2) the titles of numbered articles and identified references to Paragraphs, Subparagraphs and Clauses in the document, or (3) the titles of other

documents published by the American Institute of Engineers.

1.4 INTERPRETATION

1.4.1 In the interest of brevity the Contract Documents frequently omit modifying words such as "all" and "any" and articles such as "the" and "an," but the fact that a modifier or an article is absent from one statement and appears in another is not intended to affect the interpretation of either statement.

1.5 EXECUTION OF CONTRACT DOCUMENTS

1.5.1 The Contract Documents shall be enumerated on attachment(s) to the Agreement and attachments(s) shall be signed by the Owner and Contractor as provided in the Agreement.

1.5.2 Execution of the Contract by the Contractor is a representation that the Contractor has visited the site, become familiar with local conditions under which the work is to be performed and correlated personal observations with requirements of the Contract Documents. Contractor shall verify the location of all easements before beginning the project.

1.6 OWNERSHIP AND USE OF ENGINEER'S DRAWINGS, SPECIFICATIONS AND OTHER DOCUMENTS:

1.6.1. The Drawings, Specifications and other documents, including those in electronic form, prepared by the Engineer and/or Engineer's consultants are Instruments of the Engineer's service through which the Work to be executed by the Contractor is described. The Contractor may retain one contract record set. Neither the Contractor, nor any Subcontractor, Sub-subcontractor or material or equipment supplier shall own or claim a copyright in the Drawings, Specifications and other documents prepared by the Engineer or the Engineer's consultants, and unless otherwise indicated the Engineer or the Engineer's consultants shall be deemed the author of them and will retain all common law, statutory and other reserved rights, in addition to the copyright, unless indicated differently in the Owner – Engineer Agreement. The Drawings, Specifications and other documents prepared by the Engineer, and copies thereof furnished to the Contractor, are for use solely with respect to this Project. They are not to be used by the Contractor or any Subcontractor, Sub-subcontractor or material or equipment supplier on other projects or for additions to this Project outside the scope of the work without the specific written consent of the Owner, Engineer and/or Engineer's consultants. The Contractor, Subcontractors, Sub-subcontractors and material or equipment suppliers are granted a limited license to use and reproduce applicable portions of the Drawings, Specifications and other documents prepared by the Engineer and/or Engineer's consultants appropriate to and for use in the execution of their Work under the Contract Documents. All copies made under this license shall bear the statutory copyright notice, if any, shown on the Drawings, Specifications and other documents prepared by the Engineer and/or the Engineer's consultants. Submittal or distribution to meet official regulatory requirements or for other purposes in connection with this Project is not to be construed as publication in derogation of the Engineer's copyright or other reserved rights.

1.6.2 CONTRACTOR'S USE OF INSTRUMENTS OF SERVICE IN ELECTRONIC FORM

1.6.2.1 Engineer may furnish or sell, at an agreed upon cost, to Contractor,

Subcontractor, Sub-subcontractor, and material and equipment supplier, or other versions of Instruments of Service in electronic form for use solely with respect to this Project. The Contract Documents executed or identified in accordance with Subparagraph 1.5.1 shall prevail in case of an inconsistency with subsequent versions made through manipulatable electronic means involving computers.

1.6.2.2 If required to be furnished, or if furnished, Engineer or Engineer's Consultants will furnish electronic data in software format in use by Engineer at the time Engineer's services are performed. Contractor, any Subcontractors or Sub-subcontractors, material or equipment suppliers, or others shall be responsible for proper storage, maintenance and conversions necessary to prevent degradation or obsolescence of data. Any change or modification in electronic data by Contractor, any Subcontractors or Sub-subcontractors, material or equipment suppliers, or others shall be at their sole risk and without liability or legal exposure to Engineer, Engineer's consultants or Owner, and to fullest extent permitted by law, the Contractor, any Subcontractors or Sub-subcontractors, material or equipment suppliers agrees to hold harmless and indemnify Engineer, Engineer's consultants and Owner from and against all claims, liabilities, losses, damages and costs, including but not limited to reasonable attorney's fees, arising there from or in connection therewith.

1.6.2.3 The Contractor, any Subcontractors or Sub-subcontractors, material or equipment suppliers, and others understand that the conversion of electronic information and data supplied by the Engineer or Engineer's consultants from the system and format used by the Engineer or Engineer's consultants to an alternative or upgraded system or format, whether performed by Engineer, Engineer's consultants or others, cannot be accomplished without the introduction of inexactitudes, anomalies, omissions and errors. In the event the electronic data furnished to the Contractor, any Subcontractors or Sub-subcontractors, material or equipment suppliers, is converted, they agree to assume all risks associated with such conversion. If Engineer and/or Engineer's consultants furnish electronic data, the Contractor, any Subcontractors or Sub-subcontractors, material or equipment suppliers, and others agrees to hold Engineer, Engineer's consultants and Owner harmless and to waive any and all claims, liabilities, losses, damages and costs arising out of, or in any way connected with, the conversion of electronic data supplied by the Engineer or Engineer's consultants.

1.6.2.4 If documents, including those in electronic form, are modified, revised or changed in any way by the Contractor, Subcontractor, Sub-subcontractor, and material and equipment supplier, or others, any reference to the Engineer and Engineer's consultant and any professional seals and signatures shall be removed from the documents.

1.6.2.5 In consideration for the use of the Drawings, Specifications and other documents, including those in electronic form, Contractor, Subcontractor, Sub-subcontractor, material and equipment supplier and others agree to indemnify, defend and hold harmless the Engineer, Engineer's consultants and Owner from and against, any claim or liabilities arising out of such use.

ARTICLE 2
OWNER

2.1 DEFINITION

2.1.1 The Owner is Brazos County, Texas. The term "Owner" means the Owner or the Owner's authorized representative. The Owner's representative is **Capital Project Manager**, or such other person as may from time to time be so designated by the Brazos County Commissioners Court to act on behalf of Owner.

2.1.2 The Owner upon reasonable written request shall furnish to the Contractor in writing information which is necessary and relevant for the Contractor to evaluate, give notice of or enforce mechanic's lien rights. Such information shall include a correct statement of the record legal title to the property on which the Project is located, usually referred to as the site, and the Owner's interest therein at the time of execution of the Agreement and within five (5) days after any change, information of such change in title, recorded or unrecorded.

2.2 INFORMATION AND SERVICES REQUIRED OF THE OWNER

2.2.1 The Owner shall furnish surveys describing physical characteristics and legal limitations for the site of the Project, and a legal description of the site. The Contractor shall be entitled to rely on the accuracy of information furnished by the Owner but shall exercise proper precautions relating to the safe performance of the Work.

2.2.2 Except for permits and fees, including those required under Paragraph 3.7, which are the responsibility of the Contractor under the Contract Documents, Owner shall secure and pay for necessary approvals, easements, assessments and charges required for construction.

2.2.3 Information or services required of the Owner by the Contract Documents shall be furnished by the Owner with reasonable promptness and complete and accurate to the best of the Owner's information and belief. Any other information or services relevant to the Contractor's performance of the Work under the Owner's control shall be furnished by the Owner after receipt from the Contractor of a written request for such information or services.

2.2.4 Contractor will be furnished, free of charge, one set of Contract Documents in Adobe "PDF" file format suitable for plotting or printing. Contractor may use for limited purpose of making prints thereof required for use in performance of Work, in accordance with Paragraph 1.6.

2.2.5 The foregoing are in addition to other duties and responsibilities of the Owner enumerated herein and especially those in respect to Article 6 (Construction by Owner or by Separate Contractors), Article 9 (Payments and Completion) and Article 11 (Insurance and Bonds).

2.3 OWNER'S RIGHT TO STOP THE WORK: If the Contractor fails to correct Work which is not in accordance with the requirements of the Contract Documents as required by Paragraph 12.2 or fails, more than once, to carry out Work in accordance with the Contract Documents, the Owner by written order may order the Contractor to stop the Work, or any portion thereof, until the cause for such order has been eliminated;

however, the right of the Owner to stop the Work shall not give rise to a duty on the part of the Owner to exercise this right for the benefit of the Contractor or any other person or entity, except to the extent required by Subparagraph 6.1.3. Owner does not waive the right to stop the work in any future situation if Owner waives this right in any one situation.

2.4 OWNER'S RIGHT TO CARRY OUT THE WORK

2.4.1 If the Contractor defaults or neglects to carry out the Work, or any portion thereof, in accordance with the Contract Documents or fails to complete, within the time period stipulated, any items of work scheduled to be done subsequent to the Date of Substantial Completion or fails to complete or correct any items of work disclosed subsequent to the Date of Substantial Completion and fails within a seven day period after receipt of written notice from Owner to commence and continue correction of such default or neglect with diligence and promptness, the Owner may, without prejudice to other remedies the Owner may have, correct such deficiencies. In such case, an appropriate Change Order shall be issued deducting from payments then, or thereafter, due the Contractor the cost of correcting such deficiencies, including compensation for the Engineer's additional services and expenses made necessary by such default, neglect or failure. Such action by the Owner and amounts charged to the Contractor shall be done after consultation with the Engineer. If payments then or thereafter due the Contractor are not sufficient to cover such amounts, the Contractor shall pay the difference to the Owner.

2.4.2 Neither Owner nor its officers, agents, or employees are in any way liable or accountable to Contractor or its Surety for any method by which completion of said Work, or any portion thereof, is accomplished or for price paid therefore, unless Surety is required to pay cost to complete the Project, in excess of the amount contained in the Owner-Contractor Agreement, as a direct result of the Engineer's negligent issuance of Certificate(s) for Payment. Contractor and Surety are responsible for all costs for completing the Work including cost in excess of original Contract Sum. Owner does not forfeit right to recover damages from Contractor or Surety for failure to complete Contract by taking over the Work or by declaring Contract in default. Maintenance of the Work remains Contractor's and Surety's responsibility as provided for in Performance Bond and guarantee of Contractor.

2.4.3 The Owner reserves the right to:

2.4.3.1 observe the work, at any time, whenever it is in preparation or progress;

2.4.3.2 make emergency repairs to the work during the guarantee period, to prevent further damages and the Contractor shall pay for such repairs when necessitated by defects in the Contractor's work;

2.4.3.3 make changes to the work.

2.4.4 The Owner shall not be required to accept from the Contractor (unless specifically agreed upon):

2.4.4.1 Partial Substantial Completion;

2.4.4.2 Substantial Completion when it occurs prior to the expiration of the Construction Time.

ARTICLE 3 CONTRACTOR

3.1 GENERAL

3.1.1 The Contractor is the person or entity identified as such in the Agreement and is referred to throughout the Contract Documents as if singular in number. The term "Contractor" means the Contractor or the Contractor's authorized representative.

3.1.2 The Contractor shall perform the Work in accordance with the Contract Documents.

3.1.3 The Contractor shall not be relieved of obligations to perform the Work in accordance with the Contract Documents either by activities or duties of the Engineer in the Engineer's administration of the Contract, or by tests, inspections or approvals required or performed by persons or entities other than the Contractor.

3.2 REVIEW OF CONTRACT DOCUMENTS AND FIELD CONDITIONS

3.2.1 Since the Contract Documents are complementary, before starting each portion of the Work, the Contractor shall carefully study and compare the various Drawings and other Contract Documents relative to that portion of the Work, as well as the information furnished by the Owner pursuant to Subparagraph 2.2.1, shall take field measurements of any existing conditions related to that portion of the Work and shall observe any conditions at the site affecting it. These obligations are for the purpose of facilitating construction by the Contractor and are not for the purpose of discovering errors, omissions or inconsistencies in the Contract Documents; however, any errors, inconsistencies or omissions discovered by the Contractor shall be reported promptly to the Engineer as a properly prepared, timely Request For Information (RFI) in such form as the Engineer may require.

3.2.2 Any design errors or omissions noted by the Contractor during this review shall be reported promptly to the Engineer, but it is recognized that the Contractor's review is made in the Contractor's capacity as a contractor and not as a licensed design professional unless otherwise specifically provided in the Contract Documents. The Contractor is not required to ascertain that the Contract Documents are in accordance with applicable laws, statutes, ordinances, codes and rules and regulations, unless they bear upon construction means, methods, techniques or safety and health precautions, but the Contractor shall promptly report to Engineer any nonconformity discovered by or made known to the Contractor as a Request For Information (RFI) in such form as the Engineer may require.

3.2.3 If the Contractor believes that additional cost or time is involved because of clarifications, interpretations or instructions issued by the Engineer in response to the Contractor's notices or requests for information pursuant to Subparagraphs 3.2.1 and 3.2.2, the Contractor shall make Claims as provided in Subparagraphs 4.3.6 and 4.3.7. If the Contractor fails to perform the obligations of Subparagraphs 3.2.1 and 3.2.2, the Contractor shall pay such costs and damages to the Owner as would have been avoided if the Contractor had performed such obligations. The Contractor shall not be liable to the Owner or Engineer for damages resulting from errors, inconsistencies or omissions in the Contract Documents or for differences between field measurements or conditions and the Contract Documents unless the Contractor recognized such error, inconsistency,

omission or difference and knowingly failed to report it to the Engineer.

3.2.3 The Contractor shall verify the location of all easements before beginning the Project.

3.2.4 The Contractor shall perform the Work in accordance with the Contract Documents and submittals approved pursuant to Paragraph 3.12.

3.3 SUPERVISION AND CONSTRUCTION PROCEDURES

3.3.1 The Contractor shall supervise and direct the Work, using the Contractor's best skill and attention. The Contractor shall be solely responsible for and have control over construction means, methods, techniques, sequences and procedures and for coordinating all portions of the Work under the Contract, unless the Contract Documents give other specific instructions concerning these matters. If the Contract Documents give specific instructions concerning construction means, methods, techniques, sequences or procedures, the Contractor shall review, substantiate, and comply with current industry execution standards and manufacturer's current execution instructions and evaluate the jobsite safety thereof and, except as stated below, shall be fully and solely responsible for the jobsite safety of such means, methods, techniques, sequences or procedures.

If the Contractor determines that such means, methods, techniques, sequences or procedures may not be safe, the Contractor shall give timely written notice to the Owner and Engineer and shall not proceed with that portion of the Work without further written instructions from the Engineer. If the Contractor is then instructed to proceed with the required means, methods, techniques, sequences or procedures without acceptance of changes proposed by the Contractor, the Owner shall be solely responsible for any resulting loss or damage.

3.3.2 The Contractor shall be responsible to the Owner for acts and omissions of the Contractor's employees, Subcontractors and their agents and employees, and other persons performing portions of the Work under a contract with the Contractor.

3.3.3 The Contractor shall not be relieved of obligations to perform the Work in accordance with the Contract Documents either by activities or duties of the Engineer in the Engineer's administration of the Contract, or by tests, inspections or approvals required or performed by persons other than the Contractor.

3.3.4 The Contractor shall be responsible for inspection of portions of Work already performed under this Contract to determine that such portions are in proper condition to receive subsequent Work.

3.3.5 Contractor is solely responsible for coordination of scope of Work for its own forces, and of Subcontractors and suppliers, and to complete all Work, whether performed by the Contractor or a Subcontractor.

3.3.6 The Contractor must provide a full-time Project Superintendent that is named in their Proposal to the County. If there is a change in Superintendent, then the County must approve the new, proposed, full-time Project Superintendent before they start on the project.

3.3.7 Layout/grades will be per plans.

3.4 LABOR AND MATERIALS

3.4.1 Unless otherwise provided in the Contract Documents, the Contractor shall provide and pay for labor, materials, equipment, tools, construction equipment and machinery, water, utilities, transportation and other facilities and services necessary for proper execution and completion of the Work, whether temporary or permanent, and whether or not incorporated or to be incorporated in the Work.

3.4.2 The Contractor may make substitutions only if allowed by Contract Documents and with the consent of the Owner, after evaluation by the Engineer and in accordance with a Change Order, or by Owner's approval of a Substitution Request.

3.4.3 The Contractor shall enforce strict discipline and good order among the Contractor's employees and other persons carrying out the Contract. The Contractor shall not permit employment of unfit persons or persons not skilled in tasks assigned to them.

3.5 WARRANTY

3.5.1 The Contractor warrants to the Owner and Engineer that all materials and equipment furnished under this Contract will be of good quality and new unless otherwise specified and that all Work will be provided in accordance with the requirements of the Contract Documents and will be of good quality, free of faults and defects. All Work not conforming to the requirements of the Contract Documents, including substitutions or changes made by the Contractor or any subcontractor, material supplier or equipment supplier that have not been specifically identified (PRIOR to Contract award) by means of a Letter of Notice to Engineer and properly accepted and authorized by Engineer, shall be considered defective and not in agreement with the requirements of the Contract Documents, and shall be promptly corrected in accordance with the requirements of Article 12 of this Agreement and amendments thereto as set forth in Supplementary Conditions or Modifications. Notation or listing of such substitutions or changes on shop drawings or other types of submittal will not be considered acceptable to Engineer whether or not such submittal has been reviewed or stamped by Engineer. Notice must be specific and transmitted in letter form. If required by Owner or Engineer, Contractor shall furnish satisfactory evidence as to the kind and quality of materials and equipment actually provided. This warranty is not limited by the provisions of Paragraph 12.2.

3.5.2 Immediately prior to Date of Substantial Completion, Contractor shall execute and deliver to Engineer, a written warranty in approved form, stating that all materials and equipment provided and all work performed are in accordance with the requirements of the Contract Documents and authorized modifications and additions thereto; and further stating that Contractor guarantees, should any condition arise or be disclosed during the time of Contract warranty, which conditions are due to incomplete, or improper or defective materials, or due to incomplete or improper or defective workmanship or arrangement, such condition, together with all work affected in correcting such condition, shall be (upon written notice from Owner) promptly and satisfactorily corrected by Contractor at no additional cost to Owner. Contractor shall be fully responsible for the prompt, satisfactory completion of all warranty work whether performed by his own or subcontract personnel.

3.5.3 Work Covered by Warranty: Contractor's warranty shall cover all work under the Contract, whether or not any portion or trade has been assigned or sub-let. In the event any portion of the Work is performed by an assignee or subcontractor, Contractor shall obtain from such assignee and/or subcontractor a written warranty to Contractor and Owner covering their respective portion of the Work for the period required. Contractor shall deliver them, together with his own warranty, to Owner prior to final payment. Assigns' and subcontractors' warranties shall expressly provide that the same shall be enforceable directly by Owner, if he so elects, and shall run concurrently with Contractor's warranty. Warranty shall be secured by Contractor's Performance Bond as directed by Owner.

3.5.4 Time of Warranty: Contractor's warranty shall be for a period of one year from Date of Substantial Completion of the Work. Should a warranty required under any Section of the Specifications or of this Contract be for a period of more than one year, Contractor's and subcontractor's warranty, with respect to such work, shall be for such longer period. Warranty for work done subsequent to Date of Substantial Completion shall be for a period of one year from date of Final Completion or such longer period, if so specified.

3.5.5 Partial Occupancy: Should Owner occupy a portion of the Work before the date of Substantial Completion, the warranty period for that portion so occupied shall begin on the date of such occupancy as agreed in writing with Owner.

3.5.6 Objectionable Process: Where any material, process, or method or operation or application procedure is required, which in the opinion of the Contractor, would render the finished work unsuitable for the required warranty, then, before a bid is submitted, such unsuitable material, process, or application method shall be objected to in writing to Engineer, stating reasons therefore and recommending other alternate materials or methods so that the Work, when completed, will be suitable for the required warranty. In the event the Contractor's recommendations are approved, the work shall be installed in accordance therewith, and all changes in cost resulting there from shall be included in the Contract bid amount.

3.5.7 Under the requirements of this Paragraph 3.5, Contractor shall be responsible for:

3.5.7.1 Damages existing facilities, fences or other appurtenances or services when damages result from use of faulty materials or negligent workmanship.

3.5.7.2 Warranting modifications accepted under subparagraph 3.5.6 above will give satisfactory results.

3.5.7.3 Warranting substitutions will be equal or superior to the specified item or method unless he specifically lists shortcomings in his request for making substitution.

3.5.7.4 Obtaining and enforcing all subcontract warranties with particular attention being directed to enforcement of warranty work by electrical and other subcontractors.

3.6 TAXES

3.6.1 Although Owner is a tax-exempt unit of local government, the Contractor shall pay

all sales, consumer, use and similar taxes for the Work or portions thereof provided by the Contractor which may not be within Owner's exemption that are legally enacted when Contractor's bids were received or negotiations between Owner and Contractor were concluded, whether or not yet effective or merely scheduled to go into effect.

3.6.2 Contractor requires all Subcontractors, Sub-subcontractors and suppliers to bill Contractor for all sales and use taxes on all materials and equipment incorporated into Project as clearly discernible separate item to facilitate Contractor's keeping tax as separate item of expense on records. Furnish this information to Owner to enable Owner to meet state reporting requirements

3.7 PERMITS, FEES AND NOTICES

3.7.1 Unless otherwise provided in the Contract Documents, the Contractor shall secure and pay for the building permit and other permits and governmental fees, licenses and inspections necessary for proper execution and completion of the Work which are customarily secured after execution of the Contract and which are legally required when bids are received or negotiations concluded.

3.7.1.1 Owner shall secure and pay for health and environmental impact fees, water and sewer connections and impact fees, and zoning regulation fees and permits. The Contractor shall secure and pay for all other permits and governmental fees, licenses and inspections necessary for proper execution of and completion of Work which are customarily secured after execution of Contract and which are legally required when bids are received or Contract is executed.

3.7.2 The Contractor shall comply with and give notices required by applicable laws, statutes, ordinances, codes, rules, regulations and lawful orders of public authorities bearing on performance of the Work.

3.7.3 It is not the Contractor's responsibility to ascertain that the Contract Documents are in accordance with applicable laws, statutes, ordinances, building codes, and rules and regulations, unless they bear upon construction means, methods, techniques or safety and health precautions. However, if the Contractor observes that portions of the Contract Documents are at variance therewith, the Contractor shall promptly notify the Engineer and Owner in writing and necessary changes shall be accomplished by appropriate Modification.

3.7.4 If the Contractor performs Work, knowing it to be contrary to laws, statutes, ordinances, building codes, and rules and regulations without such notice to the Engineer and Owner, the Contractor shall assume full responsibility for such Work and shall bear all the costs attributable for any and all repairs required for conformance, including but not limited to, any penalties, fines or other damages realized..

3.8 ALLOWANCES

3.8.1 The Contractor shall include in the Contract Sum all allowances stated in the Contract Documents. Items covered by allowances shall be supplied for such amounts and by such persons or entities as the Owner may direct, but the Contractor shall not be required to employ persons or entities against which the Contractor makes reasonable objection.

3.8.2 Unless otherwise provided in the Contract Documents:

3.8.2.1 allowances shall cover the cost to the Contractor of materials and equipment delivered at the site and all required taxes, less applicable trade discounts;

3.8.2.2 Contractor's costs for unloading and handling at the site, labor, installation costs, overhead, profit and other expenses contemplated for stated allowance amounts shall be included in the allowances, and

3.8.2.3 whenever costs are more than or less than allowances, the Contract Sum shall be adjusted accordingly by Change Order. The amount of the Change Order shall reflect: (1) the difference between actual costs and the allowances under Clause 3.8.2.2, and (2) changes in Contractor's costs under Clause 3.8.2.3.

3.8.3 Contingency Allowance is established as follows and shall be processed pursuant to the Specifications.

3.8.3.1 Alexandar Road (002) - \$15,000.00

3.8.3.2 Alexandar Road (003) - \$20,000.00

3.8.3.3 Collette Lane - \$20,000.00

3.8.3.4 Harris Lane - \$15,000.00

3.8.3.5 Dilly Shaw Tap Road - \$20,000.00

3.8.3.6 Kurten Cemetery Road - \$25,000.00

3.8.3.7 Fickey Road (001) – \$20,000.00

3.8.3.8 Fickey Road (002) - \$20,000.00

3.8.3.9 Deep Well Road - \$10,000.00

3.9 SUPERINTENDENT

3.9.1 The Contractor shall employ a competent superintendent.

3.9.2 The Contractor, as soon as practicable after award of the Contract, shall furnish in writing to the Owner and Engineer the name and qualifications of a proposed superintendent. The Owner or Engineer may reply within fourteen (14) days to the Contractor in writing stating: (1) whether the Owner or Engineer has reasonable objection to the proposed superintendent, or (2) that the Owner or Engineer requires additional time to review. Failure of the Owner or Engineer to reply within the fourteen (14) day period shall constitute notice of no reasonable objection.

3.9.3 The Contractor shall not employ a proposed superintendent to whom the Owner or Engineer has made reasonable and timely objection. The Contractor shall not change the superintendent without the Owner's consent, which shall not unreasonably be withheld or delayed.

3.10 CONTRACTOR'S CONSTRUCTION SCHEDULES

3.10.1 The Contractor, promptly (within ten (10) days) after notification of contract award, shall prepare and submit for the Owner's and Engineer's information a Contractor's construction schedule for the Work. The schedule shall not exceed time limits current under the Contract Documents, shall be revised monthly or at appropriate intervals as required by the conditions of the Work and Project whichever is less, shall be related to the entire Project to the extent required by the Contract Documents and shall provide for expeditious and practicable execution of the Work.

3.10.1.1 Owner may authorize construction activities to commence prior to completion of Drawings and Specifications. If Drawings and Specifications require further development at the time the initial construction schedule is prepared, Contractor shall: 1) allow time in the schedule for further development of Drawings and Specifications by Engineer, including time for review by Owner and Contractor and for Contractor's coordination of Subcontractors' Work, and 2) furnish to Owner, in a timely manner, information regarding anticipated market conditions and construction cost, availability of labor, materials and equipment, and proposed methods, sequences and time schedules for construction of Work.

3.10.2 The Contractor shall prepare and keep current, for the Engineer's approval, a schedule of submittals which is coordinated with the Contractor's construction schedule and allows the Engineer reasonable time, as defined by the Engineer to review submittals. If the Contractor fails to submit a schedule, the Contractor shall not be entitled to any increase in Contract Sum or extension of Contract Time based on the time required for review of submittals.

3.10.3 The Contractor shall perform the Work in general accordance with the most recent schedules submitted to the Owner and Engineer.

3.10.4 Owner shall not be bound by any early completion deadline submitted in any schedule.

3.10.5 Owner does not approve or accept any schedule, but reserves the right to review, comment and reject.

3.11 DOCUMENTS AND SAMPLES AT THE SITE

3.11.1 The Contractor shall maintain at the site for the Owner one record copy of the Drawings, Specifications, Addenda, Change Orders and other Modifications, in good order and marked currently to record changes and selections made during construction, and in addition approved Shop Drawings, Product Data, Samples and similar required submittal. These shall be available to the Engineer and shall be delivered to the Owner upon completion of the Work.

3.12 SHOP DRAWINGS, PRODUCT DATA AND SAMPLES

3.12.1 Shop Drawings are drawings, diagrams, schedules and other data specially prepared for the Work by the Contractor or a Subcontractor, Sub-subcontractor, manufacturer, supplier or distributor to illustrate some portion of the Work.

3.12.2 Product Data are illustrations, standard schedules, performance charts,

instructions, brochures, diagrams and other information furnished by the Contractor to illustrate materials or equipment for some portion of the Work.

3.12.3 Samples are physical examples which illustrate materials, equipment or workmanship and establish standards by which the Work will be judged.

3.12.4 Shop Drawings, Product Data, Samples and similar submittals are not Contract Documents. The purpose of their submittal is to demonstrate for those portions of the Work for which submittals are required the way the Contractor proposes to conform to the information given and the design concept expressed in the Contract Documents. Review by the Engineer is subject to the limitations of Subparagraph 4.2.7. Informational submittals upon which the Engineer is not expected to take responsive action may be so identified in the Contract Documents. Submittals which are not required by the Contract Documents may be returned by the Engineer without action.

3.12.5 The Contractor shall review for compliance with the Contract Documents, approve and submit to the Engineer; Shop Drawings, Product Data, Samples and similar submittals required by the Contract Documents with reasonable promptness and in such sequence as to cause no delay in the Work or in the activities of the Owner or of separate contractors. Submittals which are not marked as reviewed for compliance with the Contract Documents and approved by the Contractor may be returned by the Engineer without action.

3.12.6 By submitting Shop Drawings, Product Data, Samples and similar submittals, the Contractor and Sub-contractor represent to the Owner and Engineer that the Contractor and Sub-contractor have (1) reviewed and approved them, (2) have reviewed for compliance with the Contract Documents, (3) determined and verified materials, field measurements and field construction criteria related thereto, or will do so, and (4) checked and coordinated the information contained within such submittals with the requirements of the Work and of the Contract Documents, and have approved the submittal.

3.12.7 The Contractor shall perform no portion of the Work requiring submittal and review of Shop Drawings, Product Data, Samples or similar submittals until the respective submittal has been approved by the Engineer. Such Work shall be in accordance with approved submittals.

3.12.7.1 The Contractor shall make all revisions as noted by Engineer and shall re-submit the required number of corrected copies of Shop Drawings, product data or samples until no exceptions are taken. The Contractor shall direct specific attention, by cover letter accompanying resubmitted Shop Drawings, to all revisions made in addition to those requested by Engineer on previous submissions, if any.

3.12.8 The Work shall be in accordance with approved submittals except that the Contractor shall not be relieved of responsibility for deviations from requirements of the Contract Documents by the Engineer's approval of Shop Drawings, Product Data, Samples or similar submittals unless the Contractor has specifically informed the Engineer in writing of such deviation at the time of submittal and the Engineer has given written approval to the specific deviation. The Contractor shall not be relieved of responsibility for errors or omissions in Shop Drawings, Product Data, Samples or similar

submittals by the Engineer's approval thereof.

3.12.9 The Contractor shall direct specific attention, in writing or on resubmitted Shop Drawings, Product Data, Samples or similar submittals, to revisions other than those requested by the Engineer on previous submittals. In absence of such written notice the Engineer's approval of a re-submission shall not apply to such revisions.

3.12.10 The Contractor shall not be required to provide professional services which constitute the practice of Engineer or engineering unless such services are specifically required by the Contract Documents for a portion of the Work or unless the Contractor needs to provide such services in order to carry out the Contractor's responsibilities for construction means, methods, techniques, sequences and procedures. The Contractor shall not be required to provide professional services in violation of applicable law. If professional design services or certifications by a design professional related to systems, materials or equipment are specifically required of the Contractor by the Contract Documents, the Owner and the Engineer will specify performance and design criteria that such services must satisfy. The Contractor shall cause such services or certifications to be provided by a properly licensed design professional, whose signature and seal shall appear on all drawings, calculations, specifications, certifications, Shop Drawings and other submittals prepared by such professional. Shop Drawings and other submittals related to the Work designed or certified by such professional, if prepared by others, shall bear such professional's written approval when submitted to the Engineer. The Owner and the Engineer shall be entitled to rely upon the adequacy, accuracy and completeness of the services, certifications or approvals performed by such design professionals, provided the Owner and Engineer have specified to the Contractor appropriate performance and design criteria that such services must satisfy. Pursuant to this Subparagraph 3.12.10, the Engineer will review, approve or take other appropriate action on submittals only for the limited purpose of checking for conformance with information given and the design concept expressed in the Contract Documents. The Contractor shall not be responsible for the adequacy of the performance or design criteria required by the Contract Documents.

3.12.11 When professional certification of performance criteria of materials, systems or equipment is required by the Contract Documents, the Engineer shall be entitled to rely upon the accuracy and completeness of such calculations and certifications.

3.13 USE OF SITE

3.13.1 The Contractor shall confine operations at the site to areas permitted by applicable laws, statutes, ordinances, policies, codes, rules and regulations, and lawful orders of public authorities and the Contract Documents and shall not unreasonably encumber the site with materials or equipment.

3.13.2 Contractor shall assume full responsibility for protection and safekeeping of materials stored on premises.

3.13.3 Contractor shall provide all necessary precautions to protect public, visitors and tenants from activities of Contractor or his agents on project.

3.14 CUTTING AND PATCHING

3.14.1 The Contractor shall be responsible for cutting, fitting or patching required to

complete the Work or to make its parts fit together properly.

3.14.2 The Contractor shall not damage or endanger a portion of the Work, or fully or partially completed construction, by the Owner, or separate contractors by cutting, patching or otherwise altering such construction, or by excavation. The Contractor shall not cut or otherwise alter such construction by the Owner, or a separate contractor, except with written consent of the Owner and of such separate contractor; such consent shall not be unreasonably withheld. The Contractor shall not unreasonably withhold from the Owner, or a separate contractor, the Contractor's consent to cutting or otherwise altering the Work.

3.15 CLEANING UP

3.15.1 The Contractor shall keep the premises and surrounding area free from accumulation of waste materials or rubbish caused by operations under the Contract. At completion of the Work the Contractor shall remove from and about the Project waste materials, rubbish, the Contractor's tools, construction equipment, machinery and surplus materials.

3.15.2 If the contractor fails to clean up as provided in the Contract Documents after reasonable notice from Owner of such failure, the Owner may do so and the cost thereof shall be charged to the Contractor.

3.16 ACCESS TO WORK

3.16.1 The Contractor shall provide governmental authorities who lawfully request access to the work, the Owner and Engineer proper facilities and equipment for access to the Work in preparation and progress wherever located.

3.17 ROYALTIES AND PATENTS

3.17.1 The Contractor shall pay all royalties and license fees. The Contractor shall defend suits or claims for infringement of patent rights and shall hold the Owner and Engineer harmless from loss (including but not limited to attorney's fees, court cost, and other cost of defense), on account thereof, but shall not be responsible for such defense or loss when a particular design, process or product of a particular manufacturer or manufacturers is required by the Contract Documents. However, if the Contractor has reason to believe that the required design, process or product is an infringement of a copyright, trademark, trade name, or similar property right or interest, or a patent, the Contractor shall be responsible for such loss unless such information is promptly furnished to the Engineer.

3.18 INDEMNIFICATION

3.18.1 *TO THE FULLEST EXTENT PERMITTED BY LAW, THE CONTRACTOR SHALL INDEMNIFY, DEFEND AND HOLD HARMLESS THE OWNER, ITS ELECTED OFFICIALS, APPOINTED OFFICIALS, OFFICERS, DIRECTORS, EMPLOYEES, AGENTS AND REPRESENTATIVES, ENGINEER, ENGINEER'S CONSULTANTS (COLLECTIVELY REFERRED TO AS THE "INDEMNITEES") FROM AND AGAINST ANY AND ALL CLAIMS, LIABILITES, DAMAGES, LOSSES, COSTS, AND EXPENSES, INCLUDING, BUT NOT LIMITED TO, ATTORNEY'S FEES, ARISING OUT OF, RESULTING FROM, OR OCCURRING IN CONNECTION WITH THE PERFORMANCE OF THE WORK PROVIDED THAT SUCH CLAIM, LIABILITY, DAMAGES, LOSS, COSTS OR EXPENSE IS ATTRIBUTABLE TO BODILY INJURY,*

SICKNESS, DISEASE, OR DEATH OR TO INJURY TO, OR DESTRUCTION OF, TANGIBLE PROPERTY (OTHER THAN THE WORK ITSELF), INCLUDING THE LOSS OF USE THEREOF IN ANY WAY OCCURRING, INCIDENT TO, ARISING OUT OF OR IN CONNECTION WITH: (A) A BREACH OF THE WARRANTIES PROVIDED BY THE CONTRACTOR; (B) THE WORK PERFORMED OR TO BE PERFORMED BY THE CONTRACTOR, ITS CONTRACTORS, SUB-CONTRACTORS, SUB-SUB-CONTRACTORS, AND SUPPLIERS, AND THEIR EMPLOYEES AND AGENTS; (C) ANY NEGLIGENT ACTION AND/OR OMISSION OF THE INDEMNITEES RELATED IN ANY WAY TO THE PROJECT WHETHER THE INDEMNITEES ARE NEGLIGENT IN WHOLE OR IN PART, AND EVEN WHEN THE LOSS IS CAUSED BY THE SOLE FAULT OR NEGLIGENCE (INCLUDING ACTS OR OMISSIONS THAT ARE CHARACTERIZED AS NEGLIGENCE PER SE, NEGLIGENCE PREMISED ON STRICT LIABILITY, OR ANY OTHER TYPE OF NEGLIGENCE) OF THE INDEMNITEES; OR (D) ANY FINES, PENALTIES, DAMAGES (INCLUDING PUNITIVE), LIABILITIES, COSTS AND EXPENSES IN CONNECTION WITH: (1) A VIOLATION OF ANY LAW, STATUTE, RULE, ORDINANCE, CODE OR OTHER REQUIREMENT OF PUBLIC AUTHORITIES; (2) MEANS, METHODS, PROCEDURES OR SEQUENCES OF EXECUTION OR PERFORMANCE OF THE WORK; AND (3) FAILURE TO SECURE AND PAY FOR PERMITS, FEES, APPROVALS, LICENSES AND INSPECTIONS FOR WHICH THE CONTRACTOR IS RESPONSIBLE UNDER THE CONTRACT DOCUMENTS. THE CONTRACTOR'S INDEMNITY OBLIGATION HEREIN SHALL NOT BE CONSTRUED TO NEGATE, ABRIDGE OR REDUCE OTHER RIGHTS OR OBLIGATIONS OF INDEMNITY THAT WOULD OTHERWISE EXIST AS TO A PARTY OR PERSON DESCRIBED IN THIS SECTION 3.18. THE SCOPE AND EXTENT OF THIS INDEMNITY SHALL NOT BE LIMITED BY THE AVAILABILITY OF COVERAGE UNDER THE CONTRACTOR'S INSURANCE AND SHALL NOT LIMIT INDEMNITEES' OTHER LEGAL REMEDIES AGAINST CONTRACTOR OR ANY OTHER PERSON OR ENTITY. THIS INDEMNIFICATION PROVISION SHALL SURVIVE TERMINATION OF THE CONTRACT.

3.18.2 In claims against any person or entity indemnified under Paragraph 3.18 by an employee of the Contractor, a Subcontractor, Sub-Sub-contractor, anyone directly or indirectly employed by them or anyone for whose acts they may be liable, the indemnification obligation under Paragraph 3.18 shall not be limited by a limitation on amount or type of damages, compensation or benefits payable by or for the Contractor or a Subcontractor under workers' or workmen's compensation acts, disability benefit acts or other employee benefit acts.

3.18.3 The obligations of the Contractor under Paragraph 3.18 shall not extend to the liability of the Engineer, the Engineer's consultants and agents and employees of any of them arising out of: (1) the preparation or approval of maps, drawings, opinions, reports, surveys, Change Orders, designs or specifications; or (2) the giving of, or the failure to give, directions or instructions by the Engineer, the Engineer's consultants and agents and employees of any of them, provided such giving, or failure to give, is the primary cause of the injury or damage. The indemnity for the Engineer, the Engineer's Consultants, agents and employees does not extend to any indemnity prohibited by Section 130.003 of the Texas Civil Practice and Remedies Code.

3.19 ADDITIONAL REQUIREMENTS

3.19.1 Contractor shall submit to Engineer, in writing, all substitutions proposed PRIOR

TO the bid opening date. Contractor shall furnish sufficient data for evaluation! To be acceptable for project use, substitutions must be approved in writing by Engineer or by appropriate addendum.

3.19.2 Contractor shall follow manufacturer instructions. Where such instructions are in conflict with the Contract Documents, Contractor shall notify Engineer for clarification before proceeding. A copy of the manufacturer's instructions shall be kept at job site and made available to Engineer.

3.19.3 Contractor shall stop the Work affected when notified of a proposed change and when unsatisfactory results are anticipated. Contractor shall proceed only after receiving additional instructions from Engineer.

3.19.4 Contractor shall establish and maintain bench marks, and all other grades, lines, and levels necessary for the Work, report errors and inconsistencies to Engineer, in writing, before commencing work affected. Contractor shall be responsible for placement of Project Work and shall make all corrections necessary to achieve an accurate layout of Project Work.

3.19.5 Contractor shall provide acceptable access facilities to the Work for the Owner, Engineer, and all local, State and Federal authorities having jurisdiction. All access facilities shall be made safe and reasonably convenient.

3.19.6 Contractor shall prepare quotations, for proposed changes in the Work. Quotations shall be in a "break-down" form giving the number of units, unit cost of materials, tool costs, taxes, overhead, profit, etc. Quotations shall reflect credits as well as extras.

3.19.7 Contractor shall furnish written warranties using the form directed by Owner or Engineer.

3.19.8 Contractor shall secure required inspection certificates and transmit them to Engineer and Owner.

ARTICLE 4 ADMINISTRATION OF THE CONTRACT

4.0 SCHEDULE OF WORK (at a maximum, in calendar days)

Day 0: Contractors receipt of Notice to Proceed

Submittals, as needed, to be provided within a reasonable time.

Day 606: Contractor attains Substantial Completion

Day 636: Contractor attains Final Completion

4.1 ENGINEER

4.1.1 The Engineer is the person lawfully licensed to practice Engineering, or an entity lawfully practicing Engineering identified as such in the Agreement and is referred to throughout the Contract Documents as if singular in number. The term "Engineer" means the Engineer or the Engineer's authorized representative or such representative as the Engineer may designate, who may be employed by the Engineer as a consultant.

4.1.1.1 Each of these terms; "Engineer," "Engineer," "Engineer/Engineer," "A/E," or "Engineer/Engineer" shall mean Engineer, or an affiliate as otherwise provided in the Contract Documents, or duly authorized representatives, such representatives acting severally within scope of particular duties entrusted to them, unless otherwise provided in Contract Documents.

4.1.2 Duties, responsibilities and limitations of authority of the Engineer as set forth in the Contract Documents shall not be restricted, modified or extended without written consent of the Owner, Contractor and Engineer. Consent shall not be unreasonably withheld.

4.1.3 In case of termination of employment of the Engineer, the Owner shall appoint a new Engineer whose status under the Contract Documents shall be that of the former Engineer.

4.2 ENGINEER'S ADMINISTRATION OF THE CONTRACT

4.2.1 The Engineer, acting in consultation with Owner's representative, will provide administration of the Contract as described in the Contract Documents: (1) during construction; (2) until final payment is due, and (3) with the Owner's concurrence, from time to time during the correction period described in Paragraph 12.2. The Engineer will advise and consult with the Owner. The Engineer will have authority to act on behalf of the Owner only to the extent provided in the Contract Documents, unless otherwise modified by written instrument in accordance with other provisions of the Contract; however, such authority shall not be considered or construed as creating a fiduciary relationship between the Engineer and Owner.

4.2.2 The Engineer, as a representative of the Owner, will visit the site at intervals appropriate to the stage of the Contractor's operations, or as otherwise agreed by Owner and Engineer, and as Engineer deems necessary: (1) to become generally familiar with and to keep the Owner informed about the progress and aesthetic quality of the portion of the Work completed; (2) to endeavor to guard the Owner against defects and deficiencies in the Work, and (3) to determine in general if the Work observed is being performed in a manner indicating that the Work, when completed, will be in general accordance with the Contract Documents. However, the Engineer will not be required to make exhaustive or continuous on-site evaluations or inspections to check the quality or quantity of the Work. The Engineer will neither have control over or charge of, nor be responsible for, the construction means, methods, techniques, sequences or procedures, or for the safety or health precautions and programs in connection with the Work, since these are solely the Contractor's rights and responsibilities under the Contract Documents, except as provided in Subparagraph 3.3.1.

4.2.2.1 Contractor shall reimburse Owner for compensation paid to Engineer for additional site visits made necessary by fault, neglect or request of Contractor.

4.2.3 The Engineer will not have control over or charge of and will not be responsible for construction means, methods, techniques, sequences or procedures, or for safety precautions and programs in connection with the Work, since these are solely the Contractor's responsibility as provided in Paragraph 3.3. The Engineer will not be responsible for the Contractor's failure to perform the Work in accordance with the Contract Documents or failure to complete Work on schedule. The Engineer will not have

control over or charge of and will not be responsible for acts or omissions of the Contractor, Subcontractors, or their agents or employees, or of any other persons performing portions of the Work.

4.2.4 Except as otherwise provided in the Contract Documents or when direct communications have been specially authorized, the Owner and Contractor shall endeavor to communicate through the Engineer. Communications by and with the consultants shall be through the Engineer, unless otherwise approved by the Engineer. Communications by and with Subcontractors and material suppliers shall be through the Contractor. Communications by and with separate contractors shall be through the Owner. The Engineer's presence at the Project Site shall not imply concurrence or approval of the work. Contractor shall call specific items to the Engineer's attention in writing if he wishes to obtain Engineer's opinion.

4.2.5 Based on the Engineer's observations and evaluations of the Contractor's Applications for Payment, the Engineer will review and certify the amounts due the Contractor and will issue Certificates for Payment in such amounts.

4.2.6 The Engineer has authority to reject Work which does not conform to the Contract Documents. Whenever the Engineer considers it necessary or advisable for implementation of the intent of the Contract Documents, the Engineer will have authority to require additional inspection or testing of the Work in accordance with Subparagraphs 13.5.2 and 13.5.3, whether or not such Work is fabricated, installed or completed. However, neither this authority of the Engineer nor a decision made in good faith either to exercise or not to exercise such authority shall give rise to a duty or responsibility of the Engineer to the Contractor, Subcontractors, materials and equipment suppliers, their agents or employees, or other persons performing portions of the Work. All costs made necessary by such failure, including those of repeated procedures shall be at Contractor's sole expense, including compensation for Engineer's services and expenses.

4.2.7 The Engineer will review and approve or take other appropriate action upon the Contractor's submittals such as Shop Drawings, Product Data and Samples, but only for the limited purpose of checking for conformance with information given and the design concept expressed in the Contract Documents. Such review and action on the part of the Engineer is limited to only those submittals required by the Contract Documents. The Engineer's action will be taken with such reasonable promptness as to cause no delay in the Work or in the activities of the Owner, Contractor or separate contractors, while allowing sufficient time in the Engineer's professional judgment to permit adequate review by the Engineer, Engineer's consultants and Owner, if needed. Review of such submittals is not conducted for the purpose of determining the accuracy and completeness of other details such as dimensions and quantities, or for substantiating instructions for installation or performance of equipment or systems, all of which remain the responsibility of the Contractor as required by the Contract Documents. The Engineer's review of the Contractor's submittals shall not relieve the Contractor of the obligations under Paragraphs 3.3, 3.5 and 3.12. The Engineer's review shall not constitute approval of safety or health precautions or, unless otherwise specifically stated by Engineer, of any construction means, methods, techniques, sequences or procedures. The Engineer's review or approval of a specific item shall not indicate approval of an assembly of which the item is a component.

4.2.8 The Engineer will prepare Change Orders and Construction Change Directives, or other change documents for changes in the Work for the Owner's approval and execution, and the Engineer may authorize minor changes in the Work as provided in Paragraph 7.4.

4.2.9 The Engineer and Owner will conduct inspections to determine the date or dates of Substantial Completion and the date of final completion. The Engineer may receive and forward to the Owner for the Owner's review and records written warranties and related documents as required by the Contract Documents and assembled by the Contractor, and will issue a final Certificate for Payment based upon final inspection indicating the Work complies with the requirements of the Contract Documents.

4.2.10 If the Owner and Engineer agree, Engineer will provide one or more project representatives to assist in carrying out the Engineer's responsibilities at the site. The duties, responsibilities and limitations of authority of such project representatives shall be as set forth in an exhibit to be incorporated in the Contract Documents.

4.2.11 The Engineer will interpret and decide matters concerning performance under, and requirements of, the Contract Documents on written request of either the Owner or Contractor. The Engineer's response to such requests will be made in writing within any time limits agreed upon or otherwise with reasonable promptness. If no agreement is made concerning the time within which interpretations required of the Engineer shall be furnished in compliance with this Paragraph 4.2, then delay shall not be recognized on account of failure by the Engineer to furnish such interpretations until twenty (21) days after written request is received.

4.2.12 Interpretations and decisions of the Engineer will be consistent with the intent of and reasonably inferable from the Contract Documents and will be in writing or in the form of drawings.

4.2.13 The Owner's and Engineer's decisions on matters relating to aesthetic effect will be final, if consistent with the intent expressed in the Contract Documents.

4.3 CLAIMS AND DISPUTES

4.3.1 Definition. A Claim is a demand or assertion by one of the parties seeking, as a matter of right, adjustment or interpretation of Contract terms, payment of money and extension of time or other relief with respect to the terms of the Contract. The term "Claim" also includes other disputes and matters in question between the Owner and Contractor arising out of, or relating to, the Contract. Claims must be made by written notice. The responsibility to substantiate Claims shall rest with the party making the Claim.

4.3.1.1 Claims must contain following:

4.3.1.1.1 Date of the event giving rise to such Claim and, if applicable, date when the event ceased;

4.3.1.1.2 Nature of occurrence or condition giving rise to the Claim;

4.3.1.1.3 Identification of contractual provisions affected and a detailed explanation of how the Claim is contrary to those provisions;

4.3.1.1.4 An estimate of effect upon the Contract Sum, including an itemized breakdown of additional cost, if any;

4.3.1.1.5 An estimate of the effect upon the Project Schedule, including a comparison of Project Construction Schedule and schedules prepared in connection with the Claim. If required by Owner or Engineer, this shall include showing in CPM format, both critical and non-critical path activities affected and showing Project Construction Schedule and Claim sequences, durations and float substantiating delay claimed.

4.3.2 Decision of Engineer. Claims, including those alleging an error or omission by the Engineer, shall be referred initially to the Engineer for action as provided in Paragraph 4.4. A decision by the Engineer and Owner, as provided in Subparagraph 4.4.4, shall be required as a condition precedent to litigation of a Claim between the Contractor and Owner as to all such matters arising prior to the date final payment is due, regardless of: (1) whether such matters relate to execution and progress of the Work, or (2) the extent to which the Work has been completed.

4.3.3 Time Limits on Claims initiated prior to Final Payment. Claims by either party must be initiated and submitted within **twenty-one (21)** days after occurrence of the event giving rise to such Claim or within **twenty-one (21)** days after the claimant first recognizes the condition giving rise to the Claim, whichever is later. Claims must be initiated and submitted by written notice to the Engineer and the other party. An additional Claim made after the initial Claim has been implemented by Change Order will not be considered unless submitted in a timely manner.

4.3.4 Continuing Contract Performance. Pending final resolution of a Claim, unless otherwise agreed in writing or as provided in Sub-paragraph 9.7.1 and Article 14, the Contractor shall proceed diligently with performance of the Contract and the Owner shall continue to make payments in accordance with the Contract Documents.

4.3.5 Waiver of Claims: Final Payment. The making of final payment shall constitute a waiver of Claims by the Owner except those arising from:

4.3.5.1 liens, Claims, security interests or encumbrances arising out of the Contract and unsettled;

4.3.5.2 failure of the Work to comply with the requirements of the Contract Documents; or

4.3.5.3 terms of special warranties required by the Contract Documents.

4.3.6 Claims for Concealed or Unknown Conditions. If conditions are encountered at the site which are: (1) subsurface or otherwise concealed physical conditions which differ materially from those indicated in the Contract Documents, or (2) unknown physical conditions of an unusual nature, which differ materially from those ordinarily found to exist and generally recognized as inherent in construction activities of the character provided for in the Contract Documents, then notice by the observing party shall be given

to the other party promptly before conditions are disturbed. The Engineer will promptly investigate and evaluate such conditions and, if they differ materially and cause an increase or decrease in the Contractor's cost of, or time required for, performance of any part of the Work, will recommend an equitable adjustment in the Contract Sum or Contract Time, or both. If the Engineer determines that the conditions at the site are not materially different from those indicated in the Contract Documents and that no change in the terms of the Contract is justified, the Engineer shall so notify the Owner and Contractor in writing, stating the reasons. Claims by either party in opposition to such determination must be made and submitted within **twenty-one (21)** days after the Engineer has given notice of the decision. If the Owner and Contractor cannot agree on an adjustment in the Contract Sum or Contract Time, the adjustment shall be referred to the Engineer for initial determination, subject to further proceedings pursuant to Paragraph 4.4.

4.3.7 Claims for Additional Cost. If the Contractor wishes to make Claim for an increase in the Contract Sum, written notice as provided herein shall be given before proceeding to execute the Work. Prior notice is not required for Claims relating to an emergency endangering life or property arising under Paragraph 10.6. If the Contractor believes additional cost is involved for reasons including but not limited to: (1) a written interpretation from the Engineer; (2) an order by the Owner to stop the Work where the Contractor was not at fault; (3) a written order for a minor change in the Work issued by the Engineer; (4) failure of payment by the Owner; (5) termination of the Contract by the Owner; (6) Owner's suspension, or (7) other reasonable grounds, Claim shall be filed in accordance with this Paragraph 4.3.

4.3.8 Claims for Additional Time

4.3.8.1 If the Contractor wishes to make Claim for an increase in the Contract Time, written notice as provided herein shall be given. The Contractor's Claim shall demonstrate that the task is on the critical path and identify the new completion date. In the case of a continuing delay, only one Claim is necessary.

4.3.8.1.1 The Contractor's request for an increase in the time shall be submitted with pay applications. The delay impacting the critical path shall be addressed no later than the pay application for the month following the month in which the time was lost.

4.3.8.1.2 Only delay impacting the critical path of the Work shall be considered when determining if Contractor is entitled to additional time.

4.3.8.2 If adverse weather conditions are the basis for a Claim for additional time, such Claim shall be documented by data substantiating that weather conditions were abnormal for the period of time, could not have been reasonably anticipated, that weather conditions had an adverse effect on the scheduled construction and that the activities delayed by weather were on the critical path.

4.3.8.2.1 Acceptable data for substantiating a claim for additional time will be local official records. Furthermore, the effect of such abnormal weather must be demonstrated.

4.3.8.3 Claims for increase in Contract Time shall set forth in detail the circumstances that form the basis of the Claim, date upon which each cause of delay began to affect progress of Work, date upon which each cause of delay ceased to affect progress of

Work and the number of days' increase in Contract Time claimed as a consequence of each such cause of delay. Contractor shall provide such supporting documentation as Owner or Engineer may require including, where appropriate, a revised construction schedule indicating all activities affected by circumstances forming the basis of the Claim.

4.3.8.4 Contractor shall not be entitled to a separate increase in Contract Time for each one of the number of causes of delay which may have concurrent or interrelated effects on progress of Work or for concurrent delays due to fault of Contractor.

4.3.9 Injury or Damage to Person or Property. If either party to the Contract suffers injury or damage to person or property because of an act or omission of the other party, of any of the other party's employees or agents, or of others for whose acts such party is legally liable, written notice of such injury or damage, whether or not insured, shall be given to the other party within a reasonable time not exceeding **twenty-one (21)** days after first observance. The notice shall provide sufficient detail to enable the other party to investigate and evaluate the matter.

4.3.10 If unit prices are stated in the Contract Documents, or subsequently agreed upon, and if quantities originally contemplated are materially changed in a proposed Change Order or Construction Change Directive, so that application of such unit prices to quantities of Work proposed will cause substantial inequity to the Owner or Contractor, the applicable unit prices shall be equitably adjusted.

4.3.11 Owner reserves the right to audit the Contractor's costs and bid documents if Contractor files a claim against Owner.

4.3.12 Contractor, not owner, shall handle any disputes which may arise between subcontractor and owner.

4.3.13 Owner will only be required to pay for materials actually received and/or services actually provided. Owner shall not be required to pay for materials or services described in the contract that are not used or provided by the contractor in completion of the contract. This term supersedes any contradicting terms throughout the contract and or any attachments.

4.4 RESOLUTION OF CLAIMS AND DISPUTES

4.4.1 Decision of Engineer: Claims, including those alleging an error or omission by the Engineer but excluding those arising under Paragraphs 10.3 through 10.5, shall be referred initially to the Engineer for decision. An initial decision by the Engineer shall be required as a condition precedent to mediation, arbitration (if allowed) or litigation of all Claims between the Contractor and Owner arising prior to the date final payment is due, unless thirty (30) days have passed after the Claim has been referred to the Engineer with no decision having been rendered by the Engineer. The Engineer will not decide disputes between the Contractor and persons or entities other than the Owner.

4.4.2 The Engineer will review Claims and within **twenty-one (21)** days of the receipt of the Claim take one or more of the following preliminary actions within ten (10) days of receipt of a Claim: (1) request additional supporting data from the claimant or a response with supporting data from the other party; (2) reject the Claim in whole or in part; (3)

recommend approval of the Claim by the other party; (4) suggest a compromise, or (5) advise the parties that the Engineer is unable to resolve the Claim, if the Engineer lacks sufficient information to evaluate the merits of the Claim or if the Engineer concludes that, in the Engineer's sole discretion, it would be inappropriate for the Engineer to resolve the Claim.

4.4.3 In evaluating Claims, the Engineer may, but shall not be obligated to, consult with or seek information from either party or from persons with special knowledge or expertise who may assist the Engineer in rendering a decision. The Engineer may request the Owner to authorize retention of such persons at the Owner's expense.

4.4.4 If the Engineer requests a party to provide a response to a Claim or to furnish additional supporting data, such party shall respond, within ten (10) days after receipt of such request and shall either, provide a response on the requested supporting data, advise the Engineer when the response or supporting data will be furnished, or advise the Engineer that no supporting data will be furnished. Within **twenty-one (21)** days of receipt of the response or supporting data, if any, the Engineer will either reject or approve the Claim in whole or in part.

4.4.5 If a Claim has not been resolved after consideration of the foregoing and of further evidence presented by the parties or requested by the Engineer, the Engineer will notify the parties in writing that the Engineer's decision will be made within seven (7) days. Upon expiration of such time period, the Engineer will render to the parties the Engineer's written decision relative to the Claim. If any change in the Contract Sum or Contract Time or both is included as part of the Engineer's decision, Engineer will be required to submit his decision to the Brazos County Commissioners Court for final approval. If there is a surety and there appears to be a possibility of a Contractor's default, the Engineer may, but is not obligated to, notify the surety and request the surety's assistance in resolving the controversy.

ARTICLE 5 SUBCONTRACTORS

5.1 DEFINITIONS

5.1.1 A Subcontractor is a person or entity who has a direct contract with the Contractor to perform a portion of the Work at the site. The term "Subcontractor" is referred to throughout the Contract Documents as if singular in number and means a Subcontractor or an authorized representative of the Subcontractor. The term "Subcontractor" does not include a separate contractor or subcontractors of a separate contractor.

5.1.2 A Sub-subcontractor is a person or entity who has a direct or indirect contract with a Subcontractor to perform a portion of the Work at the site. The term "Sub-subcontractor" is referred to throughout the Contract Documents as if singular in number and means a Sub-subcontractor or an authorized representative of the Sub-subcontractor.

5.1.3 Engineer and Engineer's consultants may, but are not required to, communicate directly with any Subcontractor, Sub-subcontractor, or materials supplier when it is necessary to obtain information necessary for the Engineer or Engineer's consultants to complete its services on the Project. The Engineer shall endeavor to keep Contractor

informed of conversations. Requests for information, interpretation or clarification, and correspondence must all be in writing and must be routed through Contractor.

5.2 AWARD OF SUBCONTRACTS AND OTHER CONTRACTS FOR PORTIONS OF THE WORK

5.2.1 Unless otherwise stated in the Contract Documents or the bidding requirements, the Contractor, within fourteen (14) days after award of the Contract, shall furnish in writing to the Owner through the Engineer the names of persons or entities (including those who are to furnish materials or equipment fabricated to a special design) proposed for each principal portion of the work. The Engineer will promptly reply to the Contractor in writing stating whether or not the Owner or the Engineer, after due investigation, has reasonable objection to any such proposed person or entity. Failure of the Owner or Engineer to reply promptly shall constitute notice of no reasonable objection.

5.2.2 The Contractor shall not contract with a proposed person or entity to which the Owner or Engineer has made reasonable and timely objection. The Contractor shall not be required to contract with anyone to whom the Contractor has made reasonable objection.

5.2.3 If the Owner or Engineer has reasonable objection to a person or entity proposed by the Contractor, the Contractor shall propose another to whom the Owner or Engineer has no reasonable objection. The Contract Sum shall be increased or decreased by the difference in cost occasioned by such change and an appropriate Change Order shall be issued. However, no increase in the Contract Sum shall be allowed for such change unless the Contractor has acted promptly and responsively in submitting names as required.

5.2.4 The Contractor shall not change a Subcontractor, person or entity previously selected, if the Owner or Engineer makes reasonable objection to such change. Acceptance of the substitute Subcontractor after previous acceptance of a Subcontractor for any portion of the work shall not constitute reason for an increase in the Contract amount.

5.3 SUBCONTRACTUAL RELATIONS.

By appropriate written agreement, the Contractor shall require each Subcontractor, to the extent of the Work to be performed by the Subcontractor, to be bound to the Contractor by terms of the Contract Documents, and to assume toward the Contractor all the obligations and responsibilities which the Contractor, by these Documents, assumes toward the Owner and Engineer. Each subcontractor agreement shall preserve and protect the rights of the Owner and Engineer under the Contract Documents with respect to the Work to be performed by the Subcontractor so that subcontracting thereof will not prejudice such rights, and shall allow to the Subcontractor, unless specifically provided otherwise in the subcontract agreement, the benefit of all rights, remedies and redress against the Contractor that the Contractor, by the Contract Documents, has against the Owner. Where appropriate, the Contractor shall require each Subcontractor to enter into similar agreements with Sub-subcontractors.

The Contractor shall make available to each proposed Subcontractor, prior to the execution of the subcontract agreement, copies of the Contract Documents to which the Subcontractor will be bound and, upon written request of the Subcontractor, identify to

the Subcontractor terms and conditions of the proposed subcontract agreement which may be at variance with the Contract Documents. Subcontractors shall similarly make copies of applicable portions of such documents available to their respective proposed Sub-subcontractors.

5.3.2 Contractor is fully responsible for acts and omissions of Subcontractors, and persons either, directly or indirectly, employed by them or under their control, as Contractor is for their own employees.

5.3.3 Nothing in Contract Documents creates any contractual relationship between any Subcontractor or Sub-subcontractor, or other levels of contractors and subcontractors, and Owner or Engineer, except for provisions in paragraph 5.4.

5.4 CONTINGENT ASSIGNMENT OF SUBCONTRACTS

5.4.1 Each subcontract agreement for a portion of the Work is assigned by the Contractor to the Owner provided that:

5.4.1.1 Assignment is effective only after termination of the Contract by the Owner for cause pursuant to Paragraph 14.2 and only for those subcontract agreements which the Owner accepts by notifying the Subcontractor in writing, and

5.4.1.2 Assignment is subject to the prior rights of the surety, if any, obligated under bond relating to the Contract.

5.4.2 Upon such Assignment, if the Work has been suspended for more than thirty (30) days, the Subcontractor's compensation shall be equitably adjusted.

5.4.3 Contractor will provide copies of its subcontracts, agreements and current information on status of its accounts, upon demand by Owner.

ARTICLE 6

CONSTRUCTION BY OWNER OR BY SEPARATE CONTRACTORS

6.1 OWNER'S RIGHT TO PERFORM CONSTRUCTION AND TO AWARD SEPARATE CONTRACTS

6.1.1 Owner reserves the right to perform construction or operations related to the Project with the Owner's own forces and to award separate contracts in connection with other portions of the Project or other construction of operations on the site under Conditions of the Contract identical, or substantially similar, to these including those portions related to insurance and waiver of subrogation. If the Contractor claims that delay or additional cost is involved because of such action by the Owner, the Contractor shall make such Claim as provided in Paragraph 4.3.

6.1.2 When separate contracts are awarded for different portions of the Project or other construction of operations on the site, the term "Contractor" in the Contract Documents in each case shall mean the Contractor who executes each separate Owner-Contractor Agreement.

6.1.3 The Owner shall provide for coordination of the activities of the Owner's own forces and of each separate contractor with the Work of the Contractor, who shall cooperate with them. The Contractor shall participate with other separate contractors

and the Owner in reviewing their construction schedules when directed to do so. The Contractor shall make any revisions to the construction schedule and Contract Sum deemed necessary after a joint review and mutual agreement. The construction schedules shall then constitute the schedules to be used by the Contractor, separate contractors and the Owner until subsequently revised.

6.1.4 Unless otherwise provided in the Contract Documents, when the Owner performs construction or operations related to the Project with the Owner's own forces, the Owner shall be deemed to be subject to the same obligations and to have the same rights which apply to the Contractor under the Conditions of the Contract, including, without excluding others, those stated in Article 3, this Article 6 and Articles, 10, 11 and 12.

6.2 MUTUAL RESPONSIBILITY

6.2.1 The Contractor shall afford the Owner and separate Contractors reasonable opportunity for introduction and storage of their materials and equipment and performance of their activities and shall connect and coordinate the Contractor's construction and operations with theirs as required by the Contract Documents.

6.2.2 If part of the Contractor's Work depends for proper execution or results upon construction or operations by the Owner or a separate contractor, the Contractor shall, prior to proceeding with that portion of the Work, promptly report to the Engineer apparent discrepancies or defects in such other construction that would render it unsuitable for such proper execution and results. Failure of the Contractor to report shall constitute an acknowledgment that the Owner's or separate Contractors' completed, or partially completed construction, is fit and proper to receive the Contractor's Work, except as to defects not then reasonably discoverable.

6.2.3 The Owner shall be reimbursed by the Contractor for costs incurred by the Owner which are payable to a separate contractor because of delays, improperly timed activities or defective construction of the Contractor. The Owner shall be responsible to the Contractor for costs incurred by the Contractor because of delays, improperly timed activities, and damage to the Work or defective construction of a separate contractor.

6.2.4 The Contractor shall promptly remedy damage caused by the Contractor to completed or partially completed construction or to property of the Owner or separate contractors as provided in Subparagraph 10.2.5.

6.2.5 The Owner and each separate contractor shall have the same responsibilities for cutting and patching as are described for the Contractor in Paragraph 3.14.

6.3 OWNER'S RIGHT TO CLEAN UP

6.3.1 If a dispute arises among the Contractor, separate contractors and the Owner as to the responsibility under their respective contracts for maintaining the premises and surrounding area free from waste materials and rubbish, the Owner may clean up after reasonable written notice and the cost will be paid by those responsible.

ARTICLE 7
CHANGES IN THE WORK

7.1 CHANGES

7.1.1 Changes in the Work may be accomplished after execution of the Contract and without invalidating the Contract, by Change Order, Construction Change Directive or order for a minor change in the Work, subject to the limitations stated in this Article 7 and elsewhere in the Contract Documents.

7.1.2 A Change Order shall be based upon agreement among the Owner, Contractor and Engineer; a Construction Change Directive requires agreement by the Owner and Engineer and may or may not be agreed to by the Contractor and an order for a minor change in the Work may be issued by the Engineer alone.

7.1.3 Changes in the Work shall be performed under applicable provisions of the Contract Documents and the Contractor shall proceed promptly, unless otherwise provided in the Change Order, Construction Change Directive or order for a minor change in the Work.

7.1.4 If unit prices are stated in the Contract Documents, or subsequently agreed upon, and if quantities originally contemplated are so changed in a proposed Change Order or Construction Change Directive that application of such unit prices to quantities of Work proposed will cause substantial inequity to the Owner or Contractor, the applicable unit prices shall be equitably adjusted.

7.2 CHANGE ORDERS

7.2.1 A Change Order is a written instrument prepared by the Engineer and signed by the Owner, Contractor and Engineer, stating their agreement upon all of the following:

7.2.1.1 a change in the Work;

7.2.1.2 the amount of the adjustment in the Contract Sum, if any, and

7.2.1.3 the extent of the adjustment in the Contract Time, if any.

7.2.2 Methods used in determining adjustments to the Contract Sum may include those listed in Subparagraph 7.3.3.

7.3 CONSTRUCTION CHANGE DIRECTIVES

7.3.1 A Construction Change Directive is a written order prepared by the Engineer and signed by the Owner and Engineer directing a change in the Work and stating a proposed basis for adjustment, if any, in the Contract Sum or Contract Time, or both. The Owner may by Construction Change Directive, without invalidating the Contract, order changes in the Work within the general scope of the Contract consisting of additions, deletions or other revisions, the Contract Sum and Contract Time being adjusted accordingly.

7.3.2 A Construction Change Directive shall be used in the absence of total agreement on the terms of a Change Order.

7.3.3 If the Construction Change Directive provides for an adjustment to the Contract Sum, the adjustment shall be based on one of the following methods:

7.3.3.1 mutual acceptance of a lump sum properly itemized and supported by sufficient substantiating data to permit evaluation;

7.3.3.2 unit prices stated in the Contract Documents or subsequently agreed upon;

7.3.3.3 cost to be determined in a manner agreed upon by the parties and a mutually acceptable fixed or percentage fee; or

7.3.3.4 as provided in Subparagraph 7.3.6.

7.3.4 Upon receipt of a Construction Change Directive, the Contractor shall promptly proceed with the change in the Work involved and advise the Engineer of the Contractor's agreement or disagreement with the method, if any, provided in the Construction Change Directive for determining the proposed adjustment in the Contract Sum or Contract Time.

7.3.5 A Construction Change Directive signed by the Contractor indicates the agreement of the Contractor therewith, including adjustment in Contract Sum and Contract Time or the method for determining them. Such agreement shall be effective immediately and shall be recorded as a Change Order.

7.3.6 If the Contractor does not respond promptly or disagrees with the method for adjustment in the Contract Sum, the method and the adjustment shall be determined by the Engineer on the basis of reasonable expenditures and savings of those performing the Work attributable to the change, including, in case of an increase in the Contract Sum, a reasonable allowance for overhead and profit. In such case, and also under Clause 7.3.3.3, the Contractor shall keep and present, in such form as the Engineer may prescribe, an itemized accounting together with appropriate supporting data. Unless otherwise provided in the Contract Documents, costs for the purposes of this Subparagraph 7.3.6 shall be limited to the following:

7.3.6.1 costs of labor, including social security, old age and unemployment insurance, fringe benefits required by agreement or custom, and workers' or workmen's compensation insurance;

7.3.6.2 costs of materials, supplies and equipment, including cost of transportation, whether incorporated or consumed;

7.3.6.3 rental costs of machinery and equipment, exclusive of hand tools, whether rented from the Contractor or others;

7.3.6.4 costs of premiums for all bonds and insurance, permit fees, and sales, use or similar taxes related to the Work;

7.3.6.5 additional costs of supervision and field office personnel directly attributable to the change; and

7.3.6.6 the maximum allowance for overhead and profit combined included in the total cost to Owner shall be based on the following schedule:

7.3.6.6.1 for Contractor, for any work performed by his own forces, 15% of the cost;

7.3.6.6.2 for each subcontractor involved, work performed by his own forces, 10% of the cost;

7.3.6.6.3 for Contractor, for work performed by his subcontractor, 5% of the amount due the subcontractor.

7.3.7 The amount of credit to be allowed by the Contractor to the Owner for a deletion or change which results in a net decrease in the Contract Sum shall be actual net cost as confirmed by the Engineer. When both additions and credits covering related Work or substitutions are involved in a change, the allowance for overhead and profit shall be figured on the basis of net increase, if any, with respect to that change. If the net value of a change results in a credit from Contractor or subcontractor, the credit given shall be the net cost, overhead and profit.

7.3.8 Pending final determination of the total cost of a Construction Change Directive to the Owner, amounts not in dispute for such changes in the Work shall be included in Applications for Payment accompanied by a Change Order indicating the parties' agreement with part or all of such costs. For any portion of such cost that remains in dispute, the Engineer will make an interim determination for purposes of monthly certification for payment for those costs. That determination of cost shall adjust the Contract Sum on the same basis as a Change Order, subject to the right of either party to disagree and assert a claim in accordance with Article 4.

7.3.9 When the Owner and Contractor agree with the determination made by the Engineer concerning the adjustments in the Contract Sum and Contract Time, or otherwise reach agreement upon the adjustments, such agreement shall be effective immediately and shall be recorded by preparation and execution of an appropriate Change Order.

7.4 MINOR CHANGES IN THE WORK

7.4.1 To the extent allowed by law, the Engineer has authority to order minor changes in the Work not involving adjustment in the Contract Sum or extension of the Contract Time and not inconsistent with the intent of the Contract Documents. Such changes shall be effected by written order and shall be binding on the Owner and Contractor. The Contractor shall carry out such written orders promptly.

ARTICLE 8 **TIME**

8.1 DEFINITIONS

8.1.1 The Contractor shall achieve substantial completion of the Work not later than six hundred and six hundred (606) calendar days from the date of commencement, subject to adjustments of the time for completion as provided in this Agreement.

8.1.2 The date of commencement of the Work shall be effective upon the final approval

of the Agreement, receipt of performance and payment bonds and receipt by the Contractor of the written notice to proceed from either the Owner or the Engineer.

8.1.3 The date of Substantial completion is the date certified by the Engineer in accordance with Paragraph 9.8.

8.1.4 The term "day" as used in the contract documents shall mean calendar day.

8.1.5 The term "critical path" as used in the Contract Documents shall mean the project's tasks that will cause the project end date to be delayed if they are delayed. The word "critical" does not imply how important a task is; a task is critical solely because it must occur as scheduled for the project to finish on time.

8.1.6 The term "free slack time" as used in the Contract Documents shall mean the amount of time a task can be delayed without delaying another task.

8.1.7 The term "total slack time" as used in the Contract Documents shall mean the amount of time a task can be delayed without delaying the finish date of the project.

8.2 PROGRESS AND COMPLETION

8.2.1 The Contractor agrees and understands the "TIME IS OF THE ESSENCE" for anytime time periods referenced in this Contract. The Contract further agrees to the referenced times as being reasonable for performing the work."

8.2.2 The Contractor shall not, except by agreement or instruction of the Owner in writing, prematurely commence operations on the site or elsewhere or store materials or equipment on site prior to the effective date of insurance required by Article 11 to be furnished by the Contractor and Owner. The date of commencement of the Work shall not be changed by the effective date of such insurance. Unless the date of commencement is established by the Contract Documents and a notice to proceed given by the Owner, the Contractor shall notify the Owner in writing not less than five (5) days or other agreed period before commencing the Work to permit the timely filing of mortgages, mechanic's liens and other security interests.

8.2.3 The Contractor shall proceed expeditiously with adequate forces and shall achieve Substantial Completion within the Contract Time.

8.2.4 Contractor and their Subcontractors shall complete and coordinate Work in accordance with established schedule.

8.2.5 Contractor is responsible for expediting Work, identifying potential conflicts and coordination problems, and proposing measures to avoid such problems

8.2.6 Whenever it becomes apparent that any activity completion date may not be met, unless delay is related to an approved extension of time, Contractor shall take some or all of following actions and submit supplementary schedule indicating effect of action on progress and completion of Work, all without additional costs to Owner;

8.2.6.1 increase number of working hours per shift, shifts per working days, working days per week, or amount of construction equipment, or any combination of foregoing

which will substantially eliminate backlog of Work, and put Project back on schedule, and/or,

8.2.6.2 increase construction manpower in such quantity as will substantially eliminate backlog of Work, and put Project back on schedule, and/or,

8.2.6.3 reschedule activities to achieve maximum practical concurrency of accomplishment of activities, and put Project back on schedule.

8.2.7 If Contractor fails to take any of actions indicated in subparagraph 8.2.6 within three (3) days after receiving written notice, Owner may take action to attempt to put Project back on schedule, and deduct cost of such actions from money due or to become due Contractor, or shall be grounds for determination by Owner that Contractor is not prosecuting Work with such diligence as will insure completion within Contract Time. Upon such determination, Owner may terminate Contractor's right to proceed with Work, or any separable part thereof, in accordance with provisions of Article 14.

8.2.8 Contractor shall bear cost of any services of Engineer made necessary by delays in completion of Work due to actions or inactions of Contractor or any Subcontractors. Contractor shall promptly pay any such cost upon demand by Owner. At Owner's option, these costs may be deducted from any amounts otherwise due Contractor.

8.3 DELAYS AND EXTENSION OF TIME

8.3.1 Except as otherwise provided in the Contract Documents, if the Contractor is delayed at any time in the commencement or progress of the Work by an act or neglect of the Owner or Engineer, or of an employee of either, or of a separate Contractor employed by the Owner, or by changes ordered in the Work, or by labor disputes, fire, adverse conditions as provided for in 4.3.8.2, unusual delay in deliveries, unavoidable casualties or other causes beyond the Contractor's control, or by delay authorized by the Owner, or by other causes which the Owner determines may justify delay, then the Contract Time shall be extended by Change Order for such reasonable time as the Engineer and Owner may determine.

8.3.1.1 If at least seven (7) hours of work time are available out of the working day, no extensions of time will be allowed;

8.3.1.2 No extension of time will be allowed for Saturdays, Sundays, or holidays unless the Contract requires and stipulates overtime work and it has been approved in writing by Owner; and

8.3.1.3 Time extensions will not be allowed for drying of materials when it is possible for the Contractor to enclose area and materials or use an acceptable drying process.

8.3.2 There will be no delay claims by Contractor if the Contractor finishes the Project early, even if owner delays the work.

8.3.3 Claims relating to time shall be made in accordance with applicable provision of Paragraph 4.3.

8.3.4 If Contract Time is extended pursuant to paragraph 8.3, such extension shall be

the exclusive remedy of Contractor and said Contractor shall not be entitled to recover damages from Owner or Engineer.

8.3.4 Owner's exercise of any of its rights under "ARTICLE 7 - CHANGES IN THE WORK," regardless of the extent of number of such changes, or requirement of correction or re-execution of defective work, or extent of number of Engineer's interpretations or clarifications of the Contract Documents, shall not, under any circumstances, be construed as neglect or intentional interference with Contractor's performance of the Work.

ARTICLE 9 PAYMENTS AND COMPLETION

9.1 CONTRACT SUM

9.1.1 The Contract Sum is **THREE MILLION, FIVE HUNDRED AND SIXTY EIGHT THOUSAND, SEVEN HUNDRED AND SIXTY FOUR DOLLARS (\$3,568,764.00)** and, subject to authorized adjustments as provided in this Agreement, is the total amount payable by the Owner to the Contractor for performance of the Work.

9.2 SCHEDULE OF VALUES

9.2.1 Unless otherwise provided in the Contract documents, before the first application for Payment, the Contractor shall submit to the Engineer a schedule of values allocated to various portions of the Work prepared in such form and supported by such data to substantiate its accuracy as the Engineer may require. This schedule, unless objected to by the Engineer, shall be used as a basis for reviewing the Contractor's Applications for Payment.

9.2.2 The Engineer will provide to the Contractor a list of the portions or sections of work for which he wishes to have separate values included and those items for which he will require material quantities to be shown.

9.3 APPLICATIONS FOR PAYMENT

9.3.1 Unless otherwise provided in the Contract Documents; at least twenty (20) days before the date established for each progress payment, the Contractor shall submit to the Engineer an itemized Application for Payment for operations completed in accordance with the schedule of values. Such application shall be notarized and supported by such data substantiating the contractor's right to payment including the most current Contractors Construction Schedule and/or copies of requisitions from Subcontractors and material providers as the Owner or Engineer may require, and reflecting retainage if provided for elsewhere in the Contract documents.

9.3.1.2 Such applications may not include requests for payment of amounts the Contractor does not intend to pay to a Subcontractor or material supplier because of a dispute or other reason.

9.3.2 Unless otherwise provided in the Contract Documents, payments shall be made on account of materials and equipment delivered and suitably stored at the site for subsequent incorporation in the Work. If approved in advance by the Owner, payment may similarly be made for materials and equipment suitably stored off the site at a location agreed upon in writing. Payment for materials and equipment stored on or off

the site shall be conditioned upon compliance by the Contractor with procedures satisfactory to the Owner to establish the Owner's title to such materials and equipment or otherwise protect the Owner's interest, and shall include applicable insurance, storage and transportation to the site for such materials and equipment stored off the site.

9.3.3 The Contractor warrants that title to all Work covered by an Application for Payment will pass to the Owner no later than the time of payment. The Contractor further warrants that upon submittal of an Application for Payment all Work for which Certificates for Payment have been previously issued and payments received from the Owner shall, to the best of the Contractor's knowledge, information and belief, be free and clear of liens, claims, security interests or encumbrances in favor of the Contractor, Subcontractors, material suppliers or other persons or entities making a claim by reason of having provided labor, materials and equipment relating to the Work.

9.3.4 The Contractor shall submit his Application for Payment, amounting to 95% of the cost of the work performed and 95% of the materials on hand in accordance with paragraph 9.3.2 above, as of the last day of each month.

9.4 CERTIFICATES FOR PAYMENT

9.4.1 The Engineer will, within seven (7) days after receipt of the Contractor's Application for Payment and the Engineer's site visit, either, issue to the Owner a Certificate for Payment for such amount as the Engineer determines is properly due or notify the Contractor and Owner in writing of the Engineer's reasons for withholding certification in whole or in part as provided in Subparagraph 9.5.1.

9.4.2 The issuance of a Certificate for Payment will constitute a representation by the Engineer to the Owner, based on the Engineer's observations at the site and the data comprising the Application for Payment, that the Work has progressed to the point indicated and that, to the best of the Engineer's knowledge, information and belief, the observed aesthetic quality of the Work is in accordance with the Contract Documents. The Engineer's Certificate for Payment shall be based, in part, on the recommendation of the Contractor. The foregoing representations are subject to an evaluation of the Work for conformance with the Contract documents upon Substantial Completion, to results of subsequent tests and inspections, to minor deviations from the Contract Documents correctable prior to completion and to specific qualifications expressed by the Engineer. The issuance of a Certificate for Payment will further constitute a representation that the Contractor is entitled to payment in the amount certified. However, the issuance of a Certificate for Payment will not be a representation that the Engineer has: (1) made exhaustive or continuous on-site evaluations and/or inspections to check the quality or quantity of the Work; (2) reviewed construction means, methods, techniques, sequences or procedures; (3) reviewed copies of requisitions received from Subcontractors and material suppliers and other data requested by the Owner to substantiate the Contractor's right to payment; or (4) made examination to ascertain how or for what purpose the contractor has used money previously paid on account of the Contract Sum.

9.5 DECISIONS TO WITHHOLD CERTIFICATION

9.5.1 The Engineer may decide not to certify payment and may withhold a Certificate for Payment in whole or in part, to the extent reasonably necessary to protect the Owner if, in the Engineer's opinion, the representations to the Owner required by Subparagraph 9.4.2 cannot be made. If the Engineer is unable to certify payment in the amount of the

Application, the Engineer will notify the Contractor and Owner as provided in Subparagraph 9.4.1. If the Contractor and Engineer cannot agree on a revised amount, the Engineer will promptly issue a Certificate for Payment for the amount for which the Engineer is able to make such representations to the Owner. The Engineer may also decide not to certify payment or, because of subsequently discovered evidence or subsequent observations, may nullify the whole or a part of a Certificate for Payment previously issued, to such extent as may be necessary in the Engineer's opinion to protect the Owner from loss because of:

9.5.1.1 defective Work not remedied;

9.5.1.2 third party claims filed or reasonable evidence indicating probable filing of such claims;

9.5.1.3 failure of the Contractor to make payments properly to Subcontractors or for labor, materials or equipment;

9.5.1.4 reasonable evidence that the Work cannot be completed for the unpaid balance of the Contract Sum;

9.5.1.5 damage to the Owner or another contractor;

9.5.1.6 reasonable evidence that the Work will not be completed within the contract Time, and that the unpaid balance would not be adequate to cover actual or liquidated damages for the anticipated delay;

9.5.1.7 persistent failure to carry out the Work in accordance with the Contract Documents;

9.5.1.8 failure to comply with the approved Project Construction Schedule;

9.5.1.9 erroneous estimates by the Contractor or a Sub-contractor of values of Work performed, or

9.5.1.10 the existence of any event of default under the Contract Documents.

9.5.2 When the above reasons for withholding certification are removed, certification will be made for amounts previously withheld.

9.6 PROGRESS PAYMENTS

9.6.1 After the Engineer has issued a Certificate for Payment, the Owner shall make payment in the manner and within the time provided in the Contract Documents, and shall so notify the Engineer.

9.6.1.1 Owner will make partial payments to Contractor within thirty (30) days after receipt of Certificate for Payment from Engineer.

9.6.1.2 Owner may withhold payment to Contractor notwithstanding Engineer's certification, if it is necessary, in Owner's opinion, to do so to protect Owner from loss due to any of the reasons set forth in Subparagraphs 9.5.1.1 through 9.5.1.10, inclusive.

9.6.2 The Contractor shall pay each Sub-contractor any due amounts in accordance with Texas Law. The Contractor shall, by appropriate agreement with each Subcontractor, require each Subcontractor to make payments to Sub-subcontractors in similar manner.

9.6.3 The Engineer will, on request, furnish to a Sub-contractor, if practicable, information regarding percentages of completion or amounts applied for by the Contractor and action taken thereon by the Engineer on account of portions of the Work done by such Sub-contractor.

9.6.4 The Owner has the right to request written evidence from the Contractor that the Contractor has properly paid Subcontractors and material and equipment suppliers amounts paid by the Owner to the Contractor for subcontracted Work. If the Contractor fails to furnish such evidence within seven (7) days, the Owner shall have the right to contact Subcontractors to ascertain whether they have been properly paid. Neither the Owner nor Engineer shall have an obligation to pay, or to see to the payment of money, to a Subcontractor except as may otherwise be required by law.

9.6.5 Contractor's payment to material suppliers and equipment suppliers shall be treated in a manner similar to that provided in Subparagraphs 9.6.2, 9.6.3 and 9.6.4.

9.6.6 A Certificate for Payment, a progress payment, or partial or entire use or occupancy of the Project by the Owner shall not constitute acceptance of Work not in accordance with the contract Documents.

9.7 FAILURE OF PAYMENT

9.7.1. If the Engineer does not issue a Certificate for Payment, through no fault of the Contractor, within seven (7) days after receipt of the Contractor's Application for Payment, or if the Owner does not pay the contractor within seven (7) days after the date established in the Contract Documents the amount certified by the Engineer, then the Contractor may, upon seven (7) additional days' written notice to the Owner or Engineer, stop the Work until payment of the amount owing has been received. The Contract Time shall be extended appropriately and the Contract Sum shall be increased by the amount of the Contractor's reasonable costs of shut-down, delay and start-up, as provided for in the Contract Documents.

9.8 SUBSTANTIAL COMPLETION

9.8.1 Substantial Completion is the stage in the progress of the Work when the Work is complete in accordance with the Contract Documents so the Owner can occupy or utilize the Work for its intended use.

9.8.2 Unless otherwise provided in the Contract Documents, when the Contractor considers that the Work, or a portion thereof which the Owner agrees to accept separately, is substantially complete, the Contractor shall thoroughly inspect the Work and prepare and submit to the Engineer a comprehensive list of items to be completed or corrected, Contractor's Notice of Substantial Completion, and a written request for Engineer's review of the Work. The Contractor shall proceed promptly to complete and correct items on the list. Failure to include an item on such list does not alter the responsibility of the Contractor to complete all Work in accordance with the Contract

Documents. Upon approval of Substantial Completion by Brazos County, Contractor has thirty (30) days to reach Final Completion of the Work. If the Contractor does not achieve Final Completion within thirty (30) days after Substantial Completion, Contractor shall be subject to additional Liquidated Damages as set forth under paragraph 9.11.2 herein.

9.8.3 Unless otherwise provided in the Contract Documents, after receipt of the Contractor's Notice of Substantial Completion and the Contractor's list, the Engineer and Owner will make inspections to determine whether the Work or designated portion thereof is substantially complete. If the Engineer's and Owner's inspections disclose any item, whether or not included on the Contractor's list, which is not in accordance with the requirements of the Contract Documents, the Contractor shall, before issuance of the Certificate of Substantial Completion, complete or correct such item upon notification by the Engineer. In such case, the Contractor shall then submit another Contractor's Notice of Substantial Completion and a request for another inspection by the Engineer and Owner to determine Substantial Completion.

9.8.4 When the Work is substantially complete, the Engineer will prepare a Certificate of Substantial Completion which shall establish the date of Substantial Completion, shall establish responsibilities of the Owner and Contractor for security, maintenance, heat, utilities, damage to the Work and insurance, and shall fix the time within which the contractor shall finish all items on the list accompanying the Certificate. Warranties required by the Contract Documents shall commence on the date of Substantial Completion of the Work or designated portion thereof unless otherwise provided in the Certificate of Substantial Completion. The Certificate of Substantial Completion shall be submitted to the Owner and Contractor for their written acceptance or responsibilities assigned to them in such Certificate.

9.8.5 The Certificate of Substantial Completion shall be submitted to the Owner and Contractor for their written acceptance of responsibilities assigned to them in such Certificate. Upon such acceptance and consent of surety, if any, the Owner shall make payment of retainage applying to such Work or designated portion thereof. Such payment shall be adjusted for Work that is incomplete or not in accordance with the requirements of the Contract Documents.

9.9 PARTIAL OCCUPANCY OR USE

9.9.1 The Owner may occupy, or use, any completed or partially completed portion of the Work at any stage when such portion is designated by separate agreement with the Contractor, provided such occupancy or use is consented to by the insurer as required under Subparagraph 11.4.1.5 and authorized by public authorities having jurisdiction over the Work. Such partial occupancy, or use, may commence whether or not the portion is substantially complete provided that the Owner and Contractor have accepted in writing the responsibilities assigned to each of them for payments, retainage if any, security, maintenance, heat, utilities, damage to the Work and insurance, and have agreed in writing concerning the period for correction of the Work and commencement of warranties required by the Contract Documents. When the Contractor considers a portion substantially complete, or the Owner notifies the Contractor of intent to occupy or use a portion of the Work prior to substantial completion, the Contractor shall prepare and submit a list to the Engineer as provided under Subparagraph 9.8.2. Consent of the Contractor to partial occupancy or use shall not be unreasonably withheld. The stage of

the progress of the Work shall be determined by written agreement between the Owner and Contractor or, if no agreement is reached, by decision of the Engineer.

9.9.2 Immediately prior to such partial occupancy, or use, the Owner, Contractor and Engineer shall jointly inspect the area to be occupied or portion of the Work to be used in order to determine and record the condition of the Work.

9.9.3 Unless otherwise agreed upon, partial occupancy or use of a portion or portions of the Work shall not constitute acceptance of Work not complying with the requirements of the Contract Documents.

9.10 FINAL COMPLETION AND FINAL PAYMENT

9.10.1 Unless otherwise provided in the Contract Documents; the Contractor shall inspect the Work to determine that it is sufficiently complete in accordance with the Contract Documents and the Contract is fully performed. Upon receipt of Contractor's Notice of Final Completion written notice certifying that the Work is sufficiently complete in accordance with the Contract Documents, that the Contract is fully performed, that the Work is ready for final inspection and acceptance and upon receipt of a final Application for Payment, the Engineer and Owner will in a reasonable time, make such inspection and when the Engineer and Owner finds the Work acceptable under the Contract Documents and the Contract sufficiently performed, the Engineer will promptly issue a final Certificate for Payment stating that to the best of the Engineer's knowledge, information and belief, and on the basis of the Engineer's and Owner's on-site visits and inspections, the Work has been sufficiently completed in accordance with terms and conditions of the Contract Documents. The Engineer's final Certificate for Payment will constitute a further representation that conditions listed in Subparagraph 9.10.2 as precedent to the Contractor's being entitled to final payment have been fulfilled. However, 95% of the contract amount will be due and payable to Contractor as noted in said final Certificate, with the remaining 5% retainage due and payable to the Contractor within thirty (30) days after acceptance of the Work by the Owner.

9.10.2 Unless otherwise provided in the Contract Documents, neither final payment nor any remaining retained percentage shall become due until the Contractor submits to the Engineer: (1) an affidavit that payrolls, bills for materials and equipment and other indebtedness connected with the Work for which the Owner or the Owner's property might be responsible or encumbered (less amounts withheld by Owner) have been paid or otherwise satisfied; (2) a certificate evidencing that insurance required by the Contract Document to remain in force after final payment is currently in effect and will not be canceled or allowed to expire until at least thirty (30) days' prior written notice has been given to the Owner; (3) a written statement that the Contractor knows of no substantial reason that the insurance will not be renewable to cover the period required by the Contract Documents; (4) consent of surety, if any, to final payment, and (5) if required by the Owner, other data establishing payment or satisfaction of obligations, such as receipts, releases and waivers of liens, claims, security interests or encumbrances arising out of the Contract, to the extent and in such form as may be designated by the Owner, for Owner's review and approval. If a Subcontractor refuses to furnish a release or waiver required by the Owner, the Contractor may furnish a bond satisfactory to the Owner to indemnify the Owner against such lien. If such lien remains unsatisfied after payments are made, the Contractor shall refund to the Owner all money that the Owner may be compelled to pay in discharging such lien, including all costs and reasonable

attorney's fees.

9.10.3 If, after Substantial Completion of the Work, Final Completion thereof is materially delayed through no fault of the Contractor or by issuance of Change Orders affecting final completion and the Engineer so confirms, the Owner shall, upon application by the Contractor and certification by the Engineer and without terminating the Contract, make payment of the balance due for that portion of the Work fully completed and accepted. If the remaining balance for Work not fully completed or corrected is less than retainage stipulated in the Contract Documents and if bonds have been furnished the written consent of surety to payment of the balance due for that portion of the Work fully completed and accepted shall be submitted by the Contractor to the Engineer prior to certification of such payment. Such payment shall be made under terms and conditions governing final payment, except that it shall not constitute a waiver of claims.

9.10.3.1 Final payment constituting entire unpaid balance of Contract Amount will be paid by Owner to Contractor within thirty (30) days after final Certificate for Payment has been issued by Engineer.

9.10.4 The making of final payment shall constitute a waiver of Claims by the Owner except those arising from:

9.10.4.1 liens, Claims, security interests or encumbrances arising out of the Contract and unsettled;

9.10.4.2 failure of the Work to comply with the requirements of the Contract Documents;

9.10.4.3 terms of special warranties required by the Contract Documents, or

9.10.4.4 non-conforming, faulty or defective Work appearing at or after final payment.

9.10.5 Acceptance of final payment by the Contractor, a Subcontractor or material supplier shall constitute a waiver of claims by that payee except those previously made in writing and identified by that payee as unsettled at the time of final Application for Payment.

9.11 LIQUIDATED DAMAGES

9.11.1 Liquidated damages will be one thousand dollars (\$1,000.00) per day if work is not completed on time (final completion), excluding any weather days.

ARTICLE 10 **PROTECTION OF PERSONS AND PROPERTY**

10.1 SAFETY AND HEALTH PRECAUTIONS AND PROGRAMS

10.1.1 The Contractor shall be responsible for initiating, maintaining and supervising all safety and health precautions and programs in connection with the performance of the Contract. This requirement applies continuously and is not limited to normal Working hours.

10.2 SAFETY OF PERSONS AND PROPERTY

10.2.1 The Contractor shall at all times conduct all operations under this Agreement in a

manner to avoid the risk of bodily injury or risk of damage to the following:

10.2.1.1 employees on the Work and other persons who may be affected thereby, to include but not limited to the Owner and Engineer and their consultants and employees;

10.2.1.2 the Work and materials and equipment to be incorporated therein, whether in storage on or off the site, under care, custody or control of the Contractor or the Contractor's Subcontractors or Sub-subcontractors; and

10.2.1.3 other property at the site or adjacent thereto, such as trees, shrubs, lawns, walks, pavements, roadways, structures and utilities not designated for removal, relocation or replacement in the course of construction.

10.2.2 The Contractor shall comply with and give notices required by applicable laws, statutes, ordinances, codes, standards, rules, regulations, policies and lawful orders of public authorities (including reference standards issued under the Occupation Safety Act and the Occupancy Safety and Health Administration) bearing on safety and health of persons or property or their protection from damage, injury or loss.

10.2.3 The Contractor shall erect and maintain, as required by existing conditions and performance of the Contract, reasonable safeguards for safety and protection, including posting danger signs and other warnings against hazards, promulgating safety regulations and notifying owners and users of adjacent sites and utilities.

10.2.4 When use or storage of hazardous materials or equipment or unusual methods are necessary for execution of the Work, such as driving, or removal of piles, wrecking, demolition, excavation or other similar potentially dangerous work is necessary, the Contractor shall exercise utmost care and carry on such activities under supervision of properly qualified personnel and shall give Owner reasonable advance notice. Contractor is fully responsible for any and all damages, claims, and for the defense of all actions against Owner and Engineer, and their consultants and employees resulting from the prosecution of such work.

10.2.4.1 Use or storage of explosives is prohibited.

10.2.5 The Contractor shall promptly remedy damage and loss (other than damage or loss insured under property insurance required by the Contract Documents) to property referred to in Paragraphs 10.2.1.2 and 10.2.1.3 caused in whole or in part by the Contractor, a Subcontractor, a Sub-subcontractor, or anyone directly or indirectly employed by any of them or by anyone for whose acts they may be liable and for which the Contractor is responsible under Paragraphs 10.2.1.2 and 10.2.1.3, except damage or loss attributable to acts or omissions of the Owner or Engineer or anyone directly or indirectly employed by either of them, or by anyone for whose acts either of them may be liable and not attributable to the fault or negligence of the Contractor. The foregoing obligations of the Contractor are in addition to the Contractor's obligations under Paragraph 3.18.

10.2.6 The Contractor shall designate a responsible, properly trained and qualified member or members of the Contractor's organization at the site whose duties shall be the prevention of accidents, damage to property and to supervise and train personnel in

the use of dangerous and hazardous equipment, materials and substances necessary for the execution of the Work. This person shall be the Contractor's superintendent unless otherwise designated by the Contractor in writing to the Owner and Engineer.

10.2.7 The Contractor shall not permit any part of the construction or site, including new construction or existing facilities to be loaded with weights that will exceed design loads or so as to endanger safety of persons or property or cause damage or create an unsafe condition.

10.2.8 Contractor shall give notice in writing at least forty-eight (48) hours or longer if required by affected parties before breaking ground, to all persons having interests on or near site, Public Utility Companies, owners of property having structures or improvements in proximity to site of the Work, agencies, authorities, inspectors, or those otherwise in charge of property, streets, water pipes, gas pipes, sewer pipes, telephone cables, electric cables, railroads or otherwise who may be affected by Contractor's operation, in order that they may remove any obstruction for which they are responsible and have representative on site to see that their property is properly protected. Such notice does not relieve Contractor of responsibility for any damages, claims, and defense of all actions against Owner and Engineer resulting from performance of such Work in connection with or arising out of Contract.

10.2.9 All parts of Work shall be braced to resist wind or other loads. Contractor shall perform Work with the explicit understanding that the design of the Project is based on all parts of Work having been completed and as such, the methods of performance of each part of Work shall be done accordingly.

10.2.10 Temporary items such as, but not limited to: scaffolding, staging, lifting and hoisting devices, shoring, excavation, barricades, and safety and construction procedures necessary in completion of Project shall be the responsibility of the Contractor and its Subcontractors and shall comply with all applicable codes and regulations. It shall not be responsibility of Owner, Engineer or their representatives to determine if Contractor, Subcontractors or their representatives are in compliance with the aforementioned regulations.

10.2.11 The Contractor shall comply with all Federal Occupational Safety and Health Administration Hazard Communications Act (HAZCOM) requirements, including properly maintaining Materials Safety Data Sheets (MSDS) at the Project site. The Contractor shall ensure that all MSDS are compiled in a single location at the Project site, and are available to the regulating agencies. The Contractor shall indemnify and hold harmless the Owner and Engineer for their respective failure to comply with this provision.

10.2.12 The Contractor shall be responsible for any fines, penalties or charges by any regulatory body by reason of any violation of safety or health regulations. Contractor shall also be responsible for reimbursement of any OSHA fines incurred by the Engineer for Project site safety conditions created or controlled by the Contractor that result in the Engineer receiving a citation under the OSHA multi-employer citation provision.

10.2.13 The Contractor shall notify Owner's and Engineer's personnel upon arrival to the Project site of any known safety or health hazards at the Project and the precautions

they should take.

10.2.14 The Contractor shall provide safety and health equipment (excluding boots) for the Owner and Engineer to protect them from safety and health risks during the performance of their services during the construction of the Project.

10.2.15 The Engineer's review of Contractor's performance does not include review of adequacy of Contractor's safety or health measures.

10.3 HAZARDOUS MATERIALS OR SUBSTANCES

10.3.1 The Contractor is responsible for compliance with any requirements included in the Contract Documents regarding hazardous materials. If the Contractor encounters a hazardous material or substance not addressed in the Contract Documents and if reasonable precautions will be inadequate to prevent foreseeable bodily injury or death to persons resulting from a hazardous material or substance, including but not limited to, asbestos or polychlorinated biphenyl (PCB) encountered on the site by the Contractor, the Contractor shall, upon recognizing the condition, immediately stop Work in the affected area and report the condition to the Owner, in writing, with a copy to the Engineer.

10.3.1.1 The term "hazardous materials or substance" also includes, but is not limited to, asbestos, asbestos products, polychlorinated biphenyl (PCB), radon gas, industrial waste, acids, lead, alkaline, irritants, contaminants or other pollutants, excluding mild chemicals used in the cleaning of finished building materials.

10.3.2 Upon receipt of the Contractor's written notice, the Owner shall obtain the services of a licensed laboratory to verify the presence or absence of the material or substance reported by the Contractor and in the event such material or substance is found to be present, to cause it to be rendered harmless. Unless otherwise required by the Contract Documents, the Owner shall furnish in writing to the Contractor the names and qualifications of persons or entities who are to perform tests verifying the presence or absence of such material or substance or who are to perform the task of removal or safe containment of such material or substance. The Contractor will promptly reply to the Owner in writing stating whether or not either has reasonable objection to the persons or entities proposed by the Owner. If the Contractor has an objection to a person or entity proposed by the Owner, the Owner shall propose another to whom the Contractor has no reasonable objection. When the material or substance has been rendered harmless, Work in the affected area shall resume upon written agreement of the Owner and Contractor. By Change Order the Contract Time shall be extended appropriately and the Contract Sum shall be increased in the amount of the Contractor's reasonable additional costs of shut-down, delay and start-up.

10.3.3 To the fullest extent permitted by law, the Owner shall indemnify and hold harmless the Contractor, Subcontractors, Engineer, Engineer's consultants and agents and employees of any of them from and against claims, damages, losses and expenses, including but not limited to attorneys' fees, arising out of or resulting from performance of the Work in the affected area if in fact the material or substance presents the risk of bodily injury or death as described in Subparagraph 10.3.1 and has not been rendered harmless, provided that such claim, damage, loss or expense is attributable to bodily injury, sickness, disease or death, or to injury to or destruction of tangible property (other than the Work itself) except to the extent that such damage, loss or expense is to the fault

or negligence of the party seeking indemnity. Notwithstanding, the Owner does not waive its right to assert sovereign immunity.

10.3.4 The Engineer and Engineer's consultants and employees shall have no responsibility for the discovery, presence, handling, removal or disposal of, or exposure of persons, to hazardous materials or toxic substances in any form at the Project site.

10.3.5 The Owner and Engineer shall not be responsible under Paragraph 10.3 for hazardous materials and substances brought to the Project site by the Contractor unless such materials or substances were required by the Contract Documents and the Contractor so notified the Owner and Engineer. The Contractor shall notify the Owner and Engineer prior to bringing any hazardous material or substance onto the Project site.

10.3.6 If, without negligence on the part of the Contractor, the Contractor is held liable by a government agency for the cost of remediation of a hazardous material or substance solely by reason of performing Work as required by the Contract Documents, the Owner shall indemnify the Contractor for all cost and expense thereby incurred.

10.4 EMERGENCIES

10.4.1 In an emergency affecting safety or health of persons or property, the Contractor shall act, at the Contractor's discretion, to prevent threatened damage, injury or loss. Additional compensation or extension of time claimed by the Contractor on account of an emergency shall be determined as provided in Paragraph 4.3. and Article 7.

10.4.2 The Contractor shall promptly report in writing to Owner and Engineer all accidents arising out of, or in connection with, the performance of the Work, whether on or off the site, which caused death, personal injury or property damage, giving full details and statements of any witnesses. In addition, if death, serious personal injuries or serious property damages are caused, the accident shall be reported immediately by telephone or messenger to Owner and Engineer.

ARTICLE 11 **INSURANCE AND BONDS**

11.1 CONTRACTOR'S LIABILITY INSURANCE

11.1.1 The Contractor shall purchase from and maintain in a company or companies lawfully authorized to do business in the State of Texas such insurance as will protect the Contractor from claims set forth below which may arise out of, or result from, the Contractor's operations under the Contract and for which the Contractor may be legally liable, whether such operations be by Contractor or by a Subcontractor or by anyone directly, or indirectly, employed by any of them, or by anyone for whose acts any of them may be liable:

11.1.1.1 claims under workers' or workmen's compensation, disability benefit and other similar employee benefit acts which are applicable to the Work to be performed;

11.1.1.2 claims for damages because of bodily injury, occupational sickness or disease, or death of the Contractor's employees;

11.1.1.3 claims for damages because of bodily injury, sickness, disease or death of

any person other than the Contractor's employees or persons or entities excluded by statute from requirements of Subparagraph 11.1.1.1, but required by Contract Documents to provide insurance required by that Subparagraph;

11.1.1.4 claims for damages insured by usual personal injury liability coverage which are sustained by: (1) by a person as a result of an offense directly or indirectly related to employment of such person by the Contractor; or (2) by another person;

11.1.1.5 claims for damages, other than to the Work itself, because of injury to or destruction of tangible property, including loss of use resulting there from;

11.1.1.6 claims for damages because of bodily injury, death of a person or property damage arising out of ownership, maintenance or use of a motor vehicle;

11.1.1.7 claims for bodily injury or property damage arising out of completed operations;

11.1.1.8 claims involving contractual liability insurance applicable to the Contractor's obligations under Paragraph 3.18.

11.1.1.9 Liability Insurance shall include all major divisions of coverage and be on a comprehensive basis including:

11.1.1.9.1 Premises Operations (including X, C and U coverages as applicable).

11.1.1.9.2 Independent Contractors' Protective.

11.1.1.9.3 Products and Completed Operations.

11.1.1.9.4 Personal Injury Liability with Employment Exclusion deleted.

11.1.1.9.5 Contractual, including specified provision for Contractor's obligations under Paragraph 3.18.

11.1.1.9.6 Owned, non-owned and hired motor vehicles.

11.1.1.9.7 Broad Form Property Damage including Completed Operations.

11.1.1.10 If General Liability coverages are provided by a Commercial General Liability Policy on a claims-made basis, the policy date or Retroactive Date shall predate the Contract; the termination date of the policy or applicable extended reporting period shall be no earlier than the termination date of coverages required to be maintained after final payment, certified in accordance with Subparagraph 9.10.2.

11.1.2 The insurance required by Subparagraph 11.1.1 shall be written for not less than the limits of liability specified in the Bid documents or as required by law, whichever coverage is greater. Coverage shall be written on an occurrence basis and shall be maintained without interruption from date of commencement of the Work until date of final payment and termination of any coverage required to be maintained after final payment.

11.1.2.1 The insurance required by Subparagraph 11.1.1 shall be written for not less than the following limits, or greater if required by law:

11.1.2.1.1 Workers' Compensation:

11.1.2.1.1.1 State: Texas Statutory

11.1.2.1.1.2 Applicable Federal (e.g., Longshoremen harbor work, Work at or outside U.S. Boundaries): Statutory: **Not Applicable**

11.1.2.1.1.3 Maritime: **Not Applicable**

11.1.2.1.1.4 Employer's Liability: **\$ 500,000** each accident
\$ 500,000 disease, policy limit
\$ 500,000 disease, each employee

11.1.2.1.1.5 Benefits required by union labor contracts: **As Applicable**

11.1.2.1.1.6 "Texas Waiver of Our Right to Recover From Others Endorsement" shall be included in this policy. (Waiver of Subrogation)

11.1.2.1.2 Comprehensive or Commercial General Liability (including Premises-Operations; Independent Contractors' Protective: Products and Completed Operations; Broad Form Property Damage):

11.1.2.1.2.1 Bodily Injury: **\$ 1,000,000** each occurrence
\$ 1,000,000 aggregate

11.1.2.1.2.2 Property Damage: **\$ 1,000,000** each occurrence
\$ 1,000,000 aggregate

11.1.2.1.2.3 Property Damage Liability Insurance shall include coverage for the following hazards:

11.1.2.1.2.3.1 X (Explosion)

11.1.2.1.2.3.2 C (Collapse)

11.1.2.1.2.3.3 U (Underground)

11.1.2.1.2.4 Broad Form Property Coverage shall include Completed Operations.

11.1.2.1.2.5 "Texas Waiver of Our Right to Recover From Others Endorsement" shall be included in this policy. (Waiver of Subrogation)

11.1.2.1.3 Contractual Liability:

11.1.2.1.3.1 Bodily Injury: **\$ 1,000,000** each occurrence

11.1.2.1.3.2 Property Damage: **\$ 1,000,000** each occurrence

\$ 2,000,000 aggregate

11.1.2.1.4 Personal Injury with Employment Exclusion deleted: \$ 1,000,000 aggregate

11.1.2.1.5 If the General Liability coverages are provided by a Commercial Liability policy, the:

11.1.2.1.5.1 General Aggregate shall be not less than \$ 2,000,000 and it shall apply, in total, to this Project only.

11.1.2.1.5.2 Fire Damage Limit shall be not less than \$ 100,000 on any one Fire.

11.1.2.1.5.3 Medical Expense Limit shall be not less than \$ 10,000 on any one person.

11.1.2.1.5.4 "Texas Waiver of Our Right to Recover From Others Endorsement" shall be included in this policy. (Waiver of Subrogation)

**11.1.2.1.6 Umbrella Excess Liability: \$ 2,000,000 over primary insurance
\$ 10,000 retention for self-insured hazards
each occurrence**

11.1.2.1.7 Business Auto Liability (including owned, non-owned and hired vehicles):

**11.1.2.1.7.1 Bodily Injury: \$ 500,000 each person
\$ 1,000,000 each accident**

11.1.2.1.7.2 Property Damage: \$ 500,000 each occurrence

11.1.2.1.7.3 "Texas Waiver of Our Right to Recover From Others Endorsement" shall be included in this policy. (Waiver of Subrogation)

11.1.2.1.7.3.1 The State of Texas has a no-fault automobile insurance requirement. Contractor shall be certain coverage is provided which conforms to any specific stipulation in the law.

11.1.3 Certificates of Insurance acceptable to the Owner shall be filed with the Owner prior to commencement of the Work. These Certificates and the insurance policies required by this Paragraph 11.1 shall contain a provision that coverage afforded under the policies will not be canceled, or allowed to expire, until at least thirty (30) days prior written notice has been given to the Owner. If any of the foregoing insurance coverage are required to remain in force after final payment and are reasonably available, an additional certificate evidencing continuation of such coverage shall be submitted with the final Application for Payment as required by Subparagraph 9.10.2. Information concerning reduction of coverage shall be furnished by the Contractor with reasonable promptness in accordance with the Contractor's information and belief. Not later than ten (10) days from award of bid, Contractor shall deliver to the Owner, copies of the insurance certificate in accordance with the above requirements naming Owner as additional insured.

11.2 OWNER'S LIABILITY INSURANCE:

11.2.1 The Owner reserves the right to be self-insured for any and all insurance of any kind, type, or nature required by the Contract Documents.

11.2.1.1 Contractor shall purchase and maintain insurance covering Owner's contingent liability for claims which may arise from operations under the Contract.

11.2.1.1.1 Bodily Injury: \$ 1,000,000 each occurrence
\$ 1,000,000 aggregate

11.2.1.1.2 Property Damage: \$ 1,000,000 each occurrence
\$ 1,000,000 aggregate

11.3 PROPERTY INSURANCE

11.3.1 The Contractor shall purchase and maintain, in a company or companies lawfully authorized to do business in the jurisdiction in which the Project is located, property insurance written on a builder's risk "all-risk" or equivalent policy form in the amount of the initial Contract Sum, plus Engineer fees, plus value of subsequent Contract modifications and cost of materials supplied or installed by others, comprising total value for the entire Project at the site on a replacement cost basis without optional deductibles. Such property insurance shall be maintained, unless otherwise provided in the Contract Documents or otherwise agreed in writing by all persons and entities who are beneficiaries of such insurance, until final payment has been made as provided in Paragraph 9.10 or until no person or entity other than the Owner has an insurable interest in the property required by this Paragraph 11.3 to be covered, whichever is later. This insurance shall include interests of the Owner, the Contractor, Subcontractors and Sub-subcontractors in the Project. The form of policy for this coverage shall be (Completed Value) (Reporting), in the names of the Owner, Contractor, Subcontractors and Sub-subcontractors as their interests may appear in amount equal to contract sum for the Work. If Owner is damaged by failure of Contractor to maintain such insurance, then Contractor shall bear all reasonable costs properly attributable thereto.

11.3.1.1 Property insurance shall be on an "all-risk" or equivalent policy form and shall include, without limitation, insurance against the perils of fire (with extended coverage) and physical loss or damage including, without duplication of coverage, theft, vandalism, malicious mischief, collapse, earthquake, flood, windstorm, falsework, testing and startup, temporary buildings and debris removal including demolition occasioned by enforcement of any applicable legal requirements and shall cover reasonable compensation for Engineer's and Contractor's services and expenses required as a result of such insured loss.

11.3.2 Loss of Use Insurance. The Owner, at the Owner's option, may purchase and maintain such insurance as will insure the Owner against loss of use of the Owner's property due to fire or other hazards, however caused.

11.3.3 If the Contractor requests in writing that insurance for risks other than those described herein or for other special hazards be included in the property insurance policy, the Owner shall, if possible, include such insurance, and the cost thereof shall be charged to the Contractor by appropriate Change Order.

11.4 PERFORMANCE BOND AND PAYMENT BOND

11.4.1 Not later than ten (10) days from and after the date on which the award of the bid is made by the Owner, Contractor shall execute, as Principal, bonds joined in by a Surety Company of the Contractor's choice, generally referred to as a "Performance Bond" and a "Payment Bond," each in a penal sum equal to 100% of the Contract Sum. The Bonds shall be on the form provided by Owner and shall be compatible with provisions of governing authorities. Contractor shall file bonds with the Owner.

11.4.2 Surety Company executing bonds shall be acceptable to Owner and shall be authorized to do business in the State of Texas.

11.4.3 Surety Company shall list the address and phone number of the home office of its' principal place of business. Surety shall also provide the name, address and phone number of the local Agent issuing the bonds.

11.4.4 Contractor shall require attorney-in-fact who executes required bonds on behalf of surety to affix thereto a certified and current copy of power of attorney.

11.4.5 Contractor shall deliver required bonds to Owner not later than three (3) days following the date the Agreement is entered into, or if Work is to be commenced prior thereto in response to a letter of intent, Contractor shall, prior to commencement of Work, submit evidence satisfactory to Owner that such bonds will be furnished.

11.4.6 Upon the request of any person or entity appearing to be a potential beneficiary of bonds covering payment of obligations arising under the Contract, the Contractor shall promptly furnish a copy of the bonds or shall permit a copy to be made.

11.4.7 Contractor shall keep surety informed of progress of Work and where necessary, obtain surety's consent to, or waiver of: (1) notice of changes in the Work; (2) request for reduction or release of retention; (3) request for final payment; and (4) any other information required by surety.

ARTICLE 12 **UNCOVERING AND CORRECTION OF WORK**

12.1 UNCOVERING OF WORK

12.1.1 If a portion of the Work is covered contrary to the Engineer's, Owner's or governing authority's request or to requirements specifically expressed in the Contract Documents, it must, if requested in writing by the Engineer, be uncovered for the Engineer's, Owner's or governing authority's examination and be replaced at the Contractor's expense without change in the Contract Time.

12.1.2 If a portion of the Work has been covered which the Engineer, Owner or governing authority has not specifically requested to examine prior to its being covered, the Engineer, Owner or governing authority may request to see such Work and it shall be uncovered by the Contractor. If such Work is in accordance with the Contract Documents, costs of uncovering and replacement shall, by appropriate Change Order, be at the Owner's expense. If such Work is not in accordance with the Contract Documents, such cost and the cost of correction shall be at the Contractor's expense unless the condition was caused by the Owner or a separate contractor in which event

the Owner shall be responsible for payment of such costs.

12.2 CORRECTION OF WORK

12.2.1 BEFORE OR AFTER SUBSTANTIAL COMPLETION

12.2.1.1 The Contractor shall promptly correct Work rejected by the Engineer, Owner or governing authority or failing to conform to the requirements of the Contract Documents, whether observed before, or after, Substantial Completion and whether or not fabricated, installed or completed. The Contractor shall bear costs of correcting such rejected Work, including additional testing and inspections and compensation for the Engineer's services and expenses made necessary thereby.

12.2.2 AFTER SUBSTANTIAL COMPLETION

12.2.2.1 In addition to the Contractor's obligation under Paragraph 3.5, if, within one (1) year after the date of Substantial Completion of the Work, or designated portion thereof, or after the date for commencement of warranties established under Subparagraph 9.9.1, or by terms of an applicable special warranty required by the Contract Document, any of the Work is found to be not in accordance with the requirements of the Contract Documents, the Contractor shall correct it promptly after receipt of written notice from the Owner to do so unless the Owner has previously given the Contractor a written acceptance of such condition. This period of one (1) year shall be extended with respect to portions of Work first performed after Substantial Completion by the period of time between Substantial Completion and the actual performance of the Work. This obligation under this paragraph 12.2.2 shall survive acceptance of the Work under the Contract and termination of the Contract. The Owner shall give such notice promptly after discovery of the condition.

12.2.2.2 The one (1) year period for correction of Work shall be extended with respect to portions of Work first performed after Substantial Completion by the period of time between Substantial Completion and the actual completion of that portion of the Work.

12.2.2.3 The one (1) year period for correction of Work shall not be extended by corrective Work performed by the Contractor pursuant to this Paragraph 12.2.

12.2.2.4 Upon request of Owner and prior to expiration of one (1) year from date of Substantial Completion, Engineer may conduct, and Contractor shall attend, a meeting with Owner to review facility operations and performance.

12.2.3 The Contractor shall remove from the site portions of the Work which are not in accordance with the requirements of the Contract Documents and are neither corrected by the Contractor nor accepted by the Owner.

12.2.4 The Contractor shall bear the cost of correcting destroyed, or damaged, construction, whether completed or partially completed, of the Owner or separate contractors caused by the Contractor's correction or removal of Work which is not in accordance with the requirements of the Contract Documents.

12.2.5 Nothing contained in this Paragraph 12.2 shall be construed to establish a period of limitation with respect to other obligations the Contractor has under the Contract Documents. Establishment of the one (1) year period for correction of Work as described in Subparagraph 12.2.2 relates only to the specific obligation of the Contractor to correct

the Work and has no relationship to the time within which the obligation to comply with the Contract Documents may be sought to be enforced, nor to the time within which proceedings may be commenced to establish the Contractor's liability with respect to the Contractor's obligations other than specifically to correct the Work.

12.3 ACCEPTANCE OF NONCONFORMING WORK

12.3.1 If the Owner prefers to accept Work which is not in accordance with the requirements of the Contract Documents, the Owner may do so instead of requiring its removal and correction, in which case the Contract Sum will be reduced as appropriate and equitable. Contractor shall bear all direct, indirect and consequential costs attributable to Owner's evaluation of and determination to accept such defective or nonconforming Work (such costs to include but not limited to fees and charges of Engineers, engineers, testing agencies, consultants, attorneys and other professionals). Such adjustment shall be effected whether or not final payment has been made. If any such acceptance occurs prior to final payment, Owner shall be entitled to an appropriate decrease in the Contract Sum. If the acceptance occurs after final payment, an appropriate amount will be paid by the Contractor to the Owner.

ARTICLE 13 **MISCELLANEOUS PROVISIONS**

13.1 GOVERNING LAW: The Contract shall be governed by the laws of the State of Texas and venue shall be at all times Brazos County, Texas. Respondent(s) understands that Brazos County is a governmental entity subject to Texas State and Federal public information statutes. The requirements of Subchapter J, Chapter 552, Government Code, may apply to this bid and/or subsequent contract and the contractor or vendor agrees that the contract can be terminated if the contractor or vendor knowingly or intentionally fails to comply with a requirement of that subchapter. This provision is mandatory and may not be altered or deleted, as required by Sec. 552.372(b) of the Texas Government Code.

13.2 SUCCESSORS AND ASSIGNS

13.2.1 The Owner and Contractor respectively bind themselves, their partners, successors, assigns and legal representatives to the other party hereto and to partners, successors, assigns and legal representatives of such other party in respect to covenants, agreements and obligations contained in the Contract Documents. Neither party to the Contract shall assign the Contract as a whole without written consent of the other. If either party attempts to make such an assignment without such consent, that party shall nevertheless remain legally responsible for all obligations under the Contract.

13.2.2 The Owner may, without consent of the Contractor, assign the Contract to lender providing construction financing for the Project. If the lender assumes the Owner's rights and obligations under the Contract Documents. The Contractor shall execute all consents reasonably required to facilitate such assignment.

13.2.3 Contractor shall not assign any monies due or to become due hereunder without written consent of Owner and of Contractor's Surety. The Contractor shall file a copy of such consent of Surety, together with copy of assignment with Owner and Engineer. In case Contractor assigns all or any part of any monies due or to become due under this Contract, instrument of assignment must contain a clause substantially to effect that it is

agreed that right of assignees in and to any monies due or to become due to Contractor shall be subject to prior liens and claims of all persons, firms and corporations for services rendered; for payment of all laborers and mechanics for labor performed; for payment for all materials and equipment furnished and payment for all materials and equipment used or rented in performance of the Work called for in Contract; and for payment of any liens, claims, or amounts due to governments or any of their funds.

13.3 WRITTEN NOTICE: Written notice shall be deemed to have been duly served if delivered in person to the individual or a member of the firm or entity or to an officer of the corporation for which it was intended, or if delivered or sent by registered or certified mail or by courier service providing proof of delivery to the last business address known to the party giving notice.

13.4 RIGHTS AND REMEDIES

13.4.1 Duties and obligations imposed by the Contract Documents and rights and remedies available there under shall be in addition to and not a limitation of duties, obligations, rights and remedies otherwise imposed or available by law.

13.4.2 No action or failure to act by the Owner, Engineer or Contractor shall constitute a waiver of a right or duty afforded them under the Contract, nor shall such action or failure to act constitute approval of or acquiescence in a breach there under, except as may be specifically agreed in writing.

13.5 TESTS AND INSPECTIONS

13.5.1 Tests, inspections and approvals of portions of the Work required by the Contract Documents or by laws, ordinances, rules, regulations or orders of public authorities having jurisdiction shall be made at an appropriate time. Unless otherwise provided, the County shall make arrangements for such tests, inspections and approvals with an independent testing laboratory or entity, and shall bear all related costs of tests, inspections and approvals. The Contractor shall give the testing agency, Project inspector (if any), public authorities and (if requested), Engineer timely notice of when and where tests and inspections are to be made so that they may observe such procedures. The Owner shall bear costs of tests, inspections or approvals which do not become requirements until after bids are received or negotiations concluded.

13.5.2 If the Engineer, Owner, Project inspector (if any), or public authorities having jurisdiction determine that portions of the Work require additional testing, inspection or approval not included under Subparagraph 13.5.1, the Project inspector (if any), or Engineer will, upon written authorization from the Owner, instruct the Contractor to make arrangements for such additional testing, inspection or approval by an entity acceptable to the Owner, and the Contractor shall give timely notice to the testing agency, project inspector (if any), governing agency, and (if requested), Engineer of when and where tests and inspections are to be made so they may observe such procedures. The Owner shall bear such costs except as provided in Subparagraph 13.5.3.

13.5.3 If procedures for testing, inspection or approval under Subparagraphs 13.5.1 and 13.5.2 reveal failure of the portions of the Work to comply with requirements established by the Contract Documents, laws, statutes, ordinances, codes, rules or regulations, all costs made necessary by such failure including those of repeated procedures and compensation for the Engineer's services and expenses shall be at the Contractor's

expense.

13.5.4 Required certificates of testing, inspection or approval shall, unless otherwise required by the Contract Documents, be secured by the Contractor and promptly delivered to the Engineer and Project inspector (if any).

13.5.5 If the Engineer, Owner or Project inspector (if any), is to observe tests, inspections or approvals required by the Contract Documents, they will do so promptly and where practicable, at the normal place of testing.

13.5.6 Test or inspections conducted pursuant to the Contract Documents shall be made promptly to avoid unreasonable delay in the Work.

13.6 INTEREST

13.6.1 Payments due and unpaid under the Contract Documents shall bear interest from the date payment is due at the legal rate prevailing for public entities under the laws of the State of Texas.

13.7 COMMENCEMENT OF STATUTORY LIMITATION PERIOD

13.7.1 As between the Owner and Contractor:

13.7.1.1 Before Substantial Completion. Before Substantial Completion, any applicable statute of limitations shall commence to run and any alleged cause of action shall be deemed to have accrued in any and all events not later than such date of Substantial Completion;

13.7.1.2 Between Substantial Completion and Final Certificate for Payment. As to acts or failures to acts occurring subsequent to the relevant date of Substantial Completion and prior to issuance of the final Certificate for Payment, any applicable statute of limitations shall commence to run and any alleged cause of action shall be deemed to have accrued in any and all events not later than the date of issuance of the final Certificate for Payment; and

13.7.1.3 After Final Certificate for Payment. As to acts or failures to act occurring after the relevant date of issuance of the final Certificate for Payment, any applicable statute of limitations shall commence to run and any alleged cause of action shall be deemed to have accrued in any and all events not later than the date of any act or failure to act by the Contractor pursuant to any warranty provided under Paragraph 3.5, the date of any correction of the Work or failure to correct the Work by the Contractor under paragraph 12.2, or the date of actual commission of any other act or failure to perform any duty or obligation by the Contractor or Owner, whichever occurs last.

13.8 EQUAL OPPORTUNITY

13.8.1 Contractor shall maintain policies of employment as follows:

13.8.1.1 Contractor and Contractor's Subcontractors shall not discriminate against any employee or applicant for employment because of race, religion, color, sex or national origin. Contractor shall take affirmative action to ensure that applicants are employed and that employees are treated during employment without regard to their race, religion, color, sex or national origin. Such action shall include, but not be limited to the following:

employment, upgrading, demotion or transfer; recruitment or recruitment advertising; layoff or termination; rates of pay or other forms of compensation; and selection for training, including apprenticeship. Contractor agrees to post in conspicuous places, available to employees and applicants for employment, notices setting forth policies of nondiscrimination.

13.8.1.2 Contractor and Contractor's Subcontractors shall, in all solicitations or advertisements for employees placed by them or on their behalf, state that all qualified applicants will receive consideration for employment without regard to race, religion, color, sex or national origin.

13.9 NON-DISCRIMINATION

13.9.1 In performance of Work, Contractor and Subcontractors agree not to discriminate against any employee or applicant for employment because of age, race, religion, color, handicap, sex, physical condition, developmental disability, sexual orientation or national origin. This provision shall include, but not be limited to the following; employment, upgrading, demotion, promotion or transfer; recruitment or recruitment advertising; layoff or termination; rates of pay or other forms of compensation; and selection for training, including apprenticeships.

ARTICLE 14 **TERMINATION OR SUSPENSION OF THE CONTRACT**

14.1 TERMINATION BY THE CONTRACTOR

14.1.1 The Contractor may terminate the Contract if the work is stopped for a period of thirty (30) days through no act or fault of the Contractor or a Subcontractor, Sub-subcontractor or their agents or employees or any other persons performing portions of the Work under the Contract with the Contractor, for any of the following reasons:

14.1.1.1 issuance of an order of a court or other public authority having jurisdiction;

14.1.1.2 an act of government, such as a declaration of national emergency, making material unavailable;

14.1.1.3 because the Engineer has not issued a Certificate for Payment and has not notified the Contractor of the reason for withholding certification as provided in Subparagraph 9.4.1, or because the Owner has not made payment on a Certificate for Payment within the time stated in the Contract Documents; or

14.1.1.4 if repeated suspensions, delays or interruptions by the Owner as described in Paragraph 14.3 constitute in the aggregate more than 100 percent of the total number of days scheduled for completion, or one hundred twenty (120) days in any three hundred sixty-five (365) day period, whichever is less.

14.1.2 If one of the above reasons exists, the Contractor may, upon seven (7) additional days written notice to the Owner and Engineer, terminate the Contract and recover from the Owner payment for Work executed and for proven loss with respect to materials, equipment, tools and construction equipment and machinery, including reasonable overhead, profit and damages.

14.1.3 If the Work is stopped for a period of sixty (60) days through no act or fault of the Contractor or a Subcontractor or their agents, employees or any other persons performing portions of the Work under the Contract with the Contractor because the Owner has persistently failed to fulfill the Owner's obligations under the Contract Documents with respect to matters important to the progress of the Work, the Contractor may, upon seven (7) additional days written notice to the Owner and the Engineer, terminate the Contract and recover from the Owner as provided in Subparagraph 14.1.2.

14.2 TERMINATION BY THE OWNER FOR CAUSE

14.2.1 The Owner may terminate the Contract if the Contractor:

14.2.1.1 persistently or repeatedly refuses or fails to supply enough properly skilled workers or proper materials;

14.2.1.2 fails to make prompt payment to Subcontractors for materials or labor in accordance with the respective agreement between the Contractor and the Subcontractors;

14.2.1.3 persistently disregards laws, ordinances, or rules, regulations or orders of a public authority having jurisdiction; or

14.2.1.4 otherwise is guilty of substantial breach of a provision of the Contract Documents.

14.2.2 When any of the above reasons exist and the Owner believes that sufficient cause exists to justify such action, the Owner may, without prejudice to any other rights or remedies of the Owner and after giving the Contractor and the Contractor's surety seven (7) days written notice, terminate employment of the Contractor and may, subject to any prior rights of the surety:

14.2.2.1 take possession of the site and of all materials, equipment, tools, construction equipment and machinery thereon owned by the Contractor;

14.2.2.2 accept assignment of subcontracts pursuant to Paragraph 5.4; and

14.2.2.3 finish the Work by whatever reasonable method the Owner may deem expedient.

14.2.3 When the Owner terminates the Contract for one of the reasons stated in Subparagraph 14.2.1, the Contractor shall not be entitled to receive further payment until the Work is finished.

14.2.4 If the unpaid balance of the Contract Sum exceeds costs of finishing the Work, including compensation for the Engineer's services and expenses made necessary thereby, such excess shall be paid to the Contractor. If such costs exceed the unpaid balance, the Contractor shall pay the difference to the Owner. This obligation for payment shall survive termination of the Contract.

14.3 SUSPENSION BY OWNER FOR CONVENIENCE

14.3.1 The Owner may, without cause, order the Contractor in writing to suspend, delay

or interrupt the Work in whole or in part for such period of time as the Owner may determine.

14.3.2 The Contract Sum and Contract Time shall be adjusted for increases in the cost and time caused by suspension, delay or interruption as described in Subparagraph 14.3.1. Adjustment of the Contract Sum shall include profit. No adjustment shall be made to the extent:

14.3.2.1 that performance is, was or would have been so suspended, delayed or interrupted by another cause for which the Contractor is responsible; or

14.3.2.2 that an equitable adjustment is made or denied under another provision of the Contract.

14.4 TERMINATION BY THE OWNER FOR CONVENIENCE

14.4.1 The Owner may, at any time, terminate the Contract for the Owner's convenience and without cause.

14.4.2 Upon receipt of written notice from the Owner of such termination for the Owner's convenience, the Contractor shall:

14.4.2.1 cease operations as directed by the Owner in the notice;

14.4.2.2 take actions necessary, or that the Owner may direct, for the protection and preservation of the Work; and

14.4.2.3 except for Work directed to be performed prior to the effective date of termination stated in the notice, terminate all existing subcontracts and purchase orders and enter into no further subcontracts and purchase orders.

14.4.3 In case of such termination for the Owner's convenience, the Contractor shall be entitled to receive payment for Work executed and costs incurred by reason of such termination, along with reasonable overhead and profit on the Work not executed.

ARTICLE 15 **ACCESS TO THE WORK**

15.1 Engineer, the Owner, and their authorized representatives, shall have access at all times to the work for inspection wherever it is in preparation or progress and the Contractor shall provide proper facilities for such access and inspection.

ARTICLE 16 **STANDARDS**

16.1 Any material specified by reference to the number, symbol or title of a specific standard, such as a Commercial Standard, a Federal specification, a trade association standard or other similar standard, shall comply with the requirements in the latest revision thereof and any amendment or supplement thereto in effect on the date of these Specifications, except as limited to type, class or grade, or modified in such reference.

16.2 The Standards referred to, except as modified in the Specifications, shall have full force and effect as though printed in the Specifications. These Standards are not furnished to bidders for the reason that the manufacturers and trade involved are assumed to be familiar with their requirements. The Engineer will furnish, upon request, information as to how copies of the standards referred to may be obtained.

16.3 It is not the intent of the Specifications to limit materials to the product of any particular manufacturer. Where definite materials, equipment and/or fixtures have been specified by name, manufacturer or catalog number, it has been done to set a definite standard and a reference for comparison of quality, application, physical conformity and other characteristics. It is not the intention to discriminate against, or prevent, any dealer, jobber or manufacturer from furnishing materials, equipment and fixtures which, in the judgment of the Engineer, expressed in writing, meet or exceed the characteristics of the specified items.

ARTICLE 17 **PROHIBITION AGAINST PERSONAL INTEREST IN CONTRACTS**

17.1 No officer or employee of Brazos County, Texas, shall have a financial interest, direct or indirect, in this Agreement or shall be financially interested, directly or indirectly, in the sale of any materials, supplies or services, except on behalf of the County as an officer or employee. Any willful violation of this Article shall constitute malfeasance in office and any officer or employee guilty thereof shall be subject to removal from his office or position. Any violation of this Article with the knowledge, express or implied, of the Contractor or Subcontractors shall render this Agreement voidable by Brazos County.

ARTICLE 18 **PREVAILING WAGE RATES**

18.1 PREVAILING WAGE RATE DETERMINATION

18.1.1 Chapter 2258, Texas Government Code, Title 10, requires state agencies, cities, counties, independent school districts and all other political subdivisions that engage in construction projects using public funds to include prevailing wage rates in the project bid documents and the construction contract.

ARTICLE 19
AUTHORITY TO CONTRACT

The County Judge is authorized to execute this Agreement upon the Commissioners Court's approval of the Agreement as set forth in the minutes of the Court's SEPTEMBER 23, 2025, meeting.

This Agreement is entered into in as of the day and year first written above and is executed in at least three (3) original copies of which one (1) is to be delivered to the Contractor, one (1) to the Engineer for use in the administration of the Contract, and the remainder to the Owner.

OWNER:
BRAZOS COUNTY, TEXAS



Brazos County Judge
330 South Texas Ave., Suite 332
Brazos, Texas 77803

Date: 9/23/25

CONTRACTOR:
SOLID BRIDGE CONSTRUCTION, LLC



Travis Hanus
Solid Bridge Construction, LLC

Date: 9-11-2025

ATTACHMENT "A"
BRAZOS COUNTY BRIDGE SCOUR REPAIR
REQUEST FOR PROPOSAL CIP 25-583

BID BOND

Travelers Casualty and Surety Company of America

KNOWN ALL BY THESE PRESENTS, That we, Solid Bridge Construction, LLC, as Principal, and Travelers Casualty and Surety Company of America, as Surety, are held and firmly bound unto Brazos County, as Obligee, in the sum of 5% of the GAB Dollars (5%) for the payment of which we bind ourselves, and our successors and assigns, jointly and severally, as provided herein.

WHEREAS, Principal has submitted or is about to submit a bid to the Obligee on a contract for Brazos County Bridge Scour ("Project").

NOW, THEREFORE, the condition of this bond is that if Obligee accepts Principal's bid, and Principal enters into a contract with Obligee in conformance with the terms of the bid and provides such bond or bonds as may be specified in the bidding or contract documents, then this obligation shall be void; otherwise Principal and Surety will pay to Obligee the difference between the amount of Principal's bid and the amount for which Obligee shall in good faith contract with another person or entity to perform the work covered by Principal's bid, but in no event shall Surety's and Principal's liability exceed the penal sum of this bond.

Signed this 19th day of August, 2025.

Solid Bridge Construction, LLC

(Principal)

By: [Signature] Travis Hous

Travelers Casualty and Surety Company of America

By: Tiffany Bice
Tiffany Bice, Attorney-in-Fact





**Travelers Casualty and Surety Company of America
Travelers Casualty and Surety Company
St. Paul Fire and Marine Insurance Company**

POWER OF ATTORNEY

KNOW ALL MEN BY THESE PRESENTS: That Travelers Casualty and Surety Company of America, Travelers Casualty and Surety Company, and St. Paul Fire and Marine Insurance Company are corporations duly organized under the laws of the State of Connecticut (herein collectively called the "Companies"), and that the Companies do hereby make, constitute and appoint **Tiffany Bice** of **MAGNOLIA** **Texas**, their true and lawful Attorney(s)-in-Fact to sign, execute, seal and acknowledge any and all bonds, recognizances, conditional undertakings and other writings obligatory in the nature thereof on behalf of the Companies in their business of guaranteeing the fidelity of persons, guaranteeing the performance of contracts and executing or guaranteeing bonds and undertakings required or permitted in any actions or proceedings allowed by law.

IN WITNESS WHEREOF, the Companies have caused this instrument to be signed, and their corporate seals to be hereto affixed, this **21st** day of **April**, **2021**.



State of Connecticut

City of Hartford ss.

By:
Robert L. Raney, Senior Vice President

On this the **21st** day of **April**, **2021**, before me personally appeared **Robert L. Raney**, who acknowledged himself to be the Senior Vice President of each of the Companies, and that he, as such, being authorized so to do, executed the foregoing instrument for the purposes therein contained by signing on behalf of said Companies by himself as a duly authorized officer.

IN WITNESS WHEREOF, I hereunto set my hand and official seal.

My Commission expires the **30th** day of **June**, **2026**



Anna P. Nowik, Notary Public

This Power of Attorney is granted under and by the authority of the following resolutions adopted by the Boards of Directors of each of the Companies, which resolutions are now in full force and effect, reading as follows:

RESOLVED, that the Chairman, the President, any Vice Chairman, any Executive Vice President, any Senior Vice President, any Vice President, any Second Vice President, the Treasurer, any Assistant Treasurer, the Corporate Secretary or any Assistant Secretary may appoint Attorneys-in-Fact and Agents to act for and on behalf of the Company and may give such appointee such authority as his or her certificate of authority may prescribe to sign with the Company's name and seal with the Company's seal bonds, recognizances, contracts of indemnity, and other writings obligatory in the nature of a bond, recognizance, or conditional undertaking, and any of said officers or the Board of Directors at any time may remove any such appointee and revoke the power given him or her; and it is

FURTHER RESOLVED, that the Chairman, the President, any Vice Chairman, any Executive Vice President, any Senior Vice President or any Vice President may delegate all or any part of the foregoing authority to one or more officers or employees of this Company, provided that each such delegation is in writing and a copy thereof is filed in the office of the Secretary; and it is

FURTHER RESOLVED, that any bond, recognizance, contract of indemnity, or writing obligatory in the nature of a bond, recognizance, or conditional undertaking shall be valid and binding upon the Company when (a) signed by the President, any Vice Chairman, any Executive Vice President, any Senior Vice President or any Vice President, any Second Vice President, the Treasurer, any Assistant Treasurer, the Corporate Secretary or any Assistant Secretary and duly attested and sealed with the Company's seal by a Secretary or Assistant Secretary; or (b) duly executed (under seal, if required) by one or more Attorneys-in-Fact and Agents pursuant to the power prescribed in his or her certificate or their certificates of authority or by one or more Company officers pursuant to a written delegation of authority; and it is

FURTHER RESOLVED, that the signature of each of the following officers: President, any Executive Vice President, any Senior Vice President, any Vice President, any Assistant Vice President, any Secretary, any Assistant Secretary, and the seal of the Company may be affixed by facsimile to any Power of Attorney or to any certificate relating thereto appointing Resident Vice Presidents, Resident Assistant Secretaries or Attorneys-in-Fact for purposes only of executing and attesting bonds and undertakings and other writings obligatory in the nature thereof, and any such Power of Attorney or certificate bearing such facsimile signature or facsimile seal shall be valid and binding upon the Company and any such power so executed and certified by such facsimile signature and facsimile seal shall be valid and binding on the Company in the future with respect to any bond or understanding to which it is attached.

I, **Kevin E. Hughes**, the undersigned, Assistant Secretary of each of the Companies, do hereby certify that the above and foregoing is a true and correct copy of the Power of Attorney executed by said Companies, which remains in full force and effect.

Dated this **19th** day of **August**, **2025**

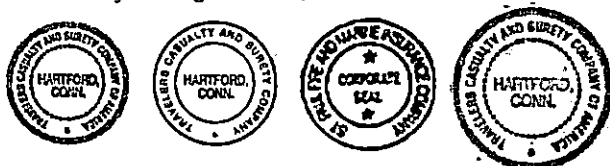

Kevin E. Hughes, Assistant Secretary

**To verify the authenticity of this Power of Attorney, please call us at 1-800-421-3880.
Please refer to the above-named Attorney(s)-in-Fact and the details of the bond to which this Power of Attorney is attached.**



Brazos County Purchasing Department

200 S. TX. AVE., STE 352 BRYAN, TX 77803
PHONE (979) 361-4292 FAX (979) 361-4293

Addendum #1 to CIP 25-583 Brazos County Bridge Scour Repair

Issued: August 11, 2025
Change: Revised Drawings, Bid Form, & Confirmation on Bid Package
Reason: Requested/Discussed in Pre-Proposal Meeting

Alexandar Road (002) Changes

- Revised grading and additional slope paving to stay within the occupied ROW
- All fence removal and replacement has been taken out of the scope of this project

Project may be awarded to up to three (3) vendors, one per group. Bid Form is setup into three (3) different groups. All respondents must turn in all three (3) groups to be considered for evaluation. With proposals, schedules with all three (3) groups must be taken in consideration, if all three (3) groups are awarded to one (1) vendor. Groups include the following:

- **Group A:**
 - o Alexander Road (002)
 - o Alexander Road (003)
 - o Collette Lane
- **Group B:**
 - o Harris Lane
 - o Dilly Shaw Tap Road
 - o Kurten Cemetery Road
- **Group C:**
 - o Fickey Road (001)
 - o Fickey Road (002)
 - o Deep Well Road

Only one (1) proposal is to be turned in to be evaluated for all three (3) groups. The evaluation score for qualifications will be used for each group. The total cost and completion time will be individually scored based on the respondent provided information for each group.

This addendum should be signed by an authorized representative of the respondent and returned with the bid documents as specified in the bid.

Acknowledgement of Addendum:

Signature: _____

Printed Name: _____

Travis Hancock

2025 Brazos County Bridge Scour Repair CIP #25-583-A Alexander Road (002)

Item	Description	QTY	Unit	Unit Price	Total
Alexander Road (002) - Bridge Scour Repair					
100	Mobilization, setup, & project overhead for duration of project, including related items and appurtenances, complete in place	1	LS	\$20,000.00	\$ 20,000.00
101	Traffic control, including Traffic Control Plans, all signage, barricades, cones, and related items and appurtenances, complete in place	1	LS	\$22,000.00	\$ 22,000.00
102	Field locate existing utilities and service lines for construction of the proposed improvements, including related items and appurtenances, complete in place	1	LS	\$ 4,500.00	\$ 4,500.00
103	Site Clean-up, 4" topsoil, fine grading of areas disturbed by construction, including related items and appurtenances, complete in place	1	LS	\$15,000.00	\$ 15,000.00
104	SWPPP, dewatering (as required) and silt fencing (537 LF), including related items and appurtenances, complete in place	1	LS	\$ 7,500.00	\$ 7,500.00
105	Hydromulch Seeding, including related items and appurtenances, complete in place	1	LS	\$ 8,500.00	\$ 8,500.00
106	ROW preparing, including all earthwork, clearing and grubbing of ROW, removal of any trees in the ROW and trimming of limbs, including related items and appurtenances, complete in place	1	LS	\$20,000.00	\$ 20,000.00
107	Remove & dispose of existing guardrail and bridge rail, including related items and appurtenances, complete in place	413	LF	\$ 14.00	\$ 5,782.00
108	Remove & dispose of existing signage, including related items and appurtenances, complete in place.	4	EA	\$ 500.00	\$ 2,000.00
109	Remove & dispose of existing asphalt pavement and base, including related items and appurtenances, complete in place.	498	SY	\$ 17.00	\$ 8,466.00
110	General Fill to Design Grades, complete in place	50	CY	\$ 40.00	\$ 2,000.00
111	Select Fill, complete in place	50	CY	\$ 40.00	\$ 2,000.00
112	Imported Cement Stabilized Sand w/ Compaction for Roadway Construction (includes cost of Cement), (Assume 4% by weight), including related items and appurtenances, complete in place	492	SY	\$ 35.00	\$ 17,220.00
113	Type R Rock Rip Rap, 200-250lbs, Hand Placed w 6" (minimum) imported cement stabilized sand in low areas (24" Embedment) for Crossing Creek, including related items and appurtenances, complete in place	191	SY	\$ 210.00	\$ 40,110.00
114	6" concrete slope paving, including cement sand, related items and appurtenances, complete in place.	145	SY	\$ 125.00	\$ 18,125.00
115	Metal Beam Guard Fence (GF(31)-19) with GF-2 reflectors, including related items and appurtenances, complete in place	282	LF	\$ 90.00	\$ 25,380.00
116	Bridge rail, including related items and appurtenances, complete in place.	80	LF	\$ 225.00	\$ 18,000.00
117	Concrete-to-Asphalt tie-in, including related items and appurtenances, complete in place	2	EA	\$ 3,000.00	\$ 6,000.00
118	8" concrete bridge approach (Class P), including related items and appurtenances, complete in place.	492	SY	\$ 100.00	\$ 49,200.00
119	4" Thick Concrete Mow Strip (Guardrail), (GF(31)MS-19), including related items and appurtenances, complete in place	188	SY	\$ 115.00	\$ 21,620.00
120	Softstop End Terminal (50'-9.5") - SGT (10S)31-16, including related items and appurtenances, complete in place	4	EA	\$ 6,000.00	\$ 24,000.00
Alexander Road (002) Construction Cost					\$ 337,403.00
Contingency... ..					\$ 15,000.00
TOTAL OPINION OF PROBABLE CONSTRUCTION COST...					\$ 352,403.00
Calendar Days to Completion					78

Item	Description	QTY	Unit	Unit Price	Total
Alexander Road (003) - Bridge Scour Repair					
200	Mobilization, setup, & project overhead for duration of project, including related items and appurtenances, complete in place	1	LS	\$20,000.00	\$ 20,000.00
201	Traffic control, including Traffic Control Plans, all signage, barricades, cones, and related items and appurtenances, complete in place	1	LS	\$22,500.00	\$ 22,500.00
202	Field locate existing utilities and service lines for construction of the proposed improvements, including related items and appurtenances, complete in place	1	LS	\$ 4,500.00	\$ 4,500.00
203	Site Clean-up, 4" topsoil, fine grading of areas disturbed by construction, including related items and appurtenances, complete in place	1	LS	\$15,000.00	\$ 15,000.00
204	SWPPP, dewatering (as required) and silt fencing (826 LF), including related items and appurtenances, complete in place	1	LS	\$ 7,500.00	\$ 7,500.00
205	Hydromulch Seeding, including related items and appurtenances, complete in place	1	LS	\$ 8,500.00	\$ 8,500.00
206	ROW preparing, including all earthwork, clearing and grubbing of ROW, removal of any trees in the ROW and trimming of limbs, including related items and appurtenances, complete in place	1	LS	\$20,000.00	\$ 20,000.00
207	Remove & dispose of existing wood in existing channel and cut piles below finished grade, including related items and appurtenances, complete in place	1	LS	\$ 5,500.00	\$ 5,500.00
208	Remove & dispose of existing guardrail and bridge rail, including related items and appurtenances, complete in place	345	LF	\$ 17.00	\$ 5,865.00
209	Remove & dispose of existing signage, including related items and appurtenances, complete in place.	4	EA	\$ 500.00	\$ 2,000.00
210	Remove & dispose of existing asphalt pavement and base, including related items and appurtenances, complete in place.	572	SY	\$ 10.00	\$ 5,720.00
211	General Fill to Design Grades, complete in place	50	CY	\$ 40.00	\$ 2,000.00
212	Select Fill, complete in place	50	CY	\$ 40.00	\$ 2,000.00
213	"Wickson Creek" signage, including pole, footing, sign, related items and appurtenances, complete in place	2	EA	\$ 1,100.00	\$ 2,200.00
214	Imported Cement Stabilized Sand w/ Compaction for Roadway Construction (includes cost of Cement), (Assume 4% by weight), including related items and appurtenances, complete in place	575	SY	\$ 35.00	\$ 20,125.00
215	Type R Rock Rip Rap, 200-250lbs, Hand Placed w 6" (minimum) imported cement stabilized sand in low areas (24" Embedment) for Crossing Creek, including related items and appurtenances, complete in place	372	SY	\$ 210.00	\$ 78,120.00
216	Metal Beam Guard Fence (GF(31)-19) with GF-2 reflectors, including related items and appurtenances, complete in place	340	LF	\$ 90.00	\$ 30,600.00
217	Bridge rail, including related items and appurtenances, complete in place.	110	LF	\$ 225.00	\$ 24,750.00
218	Concrete-to-Asphalt tie-in, including related items and appurtenances, complete in place	2	EA	\$ 3,000.00	\$ 6,000.00
219	8" concrete bridge approach (Class F), including related items and appurtenances, complete in place.	575	SY	\$ 100.00	\$ 57,500.00
220	4" Thick Concrete Mow Strip (Guardrail), (GF(31)MS-19), including related items and appurtenances, complete in place	258	SY	\$ 115.00	\$ 29,670.00
221	Softstop End Terminal (50'-9.5") - SGT (10S)31-16, including related items and appurtenances, complete in place	4	EA	\$ 6,000.00	\$ 24,000.00
Alexander Road (003) Construction Cost					\$ 394,050.00
Contingency....					\$ 20,000.00
TOTAL OPINION OF PROBABLE CONSTRUCTION COST.....					\$ 414,050.00
Calendar Days to Completion					78

Item	Description	QTY	Unit	Unit Price	
Collette Lane - Bridge Scour Repair					
300	Mobilization, setup, & project overhead for duration of project, including related items and appurtenances, complete in place	1	LS	\$22,000.00	\$ 22,000.00
301	Traffic control, including Traffic Control Plans, all signage, barricades, cones, and related items and appurtenances, complete in place	1	LS	\$22,500.00	\$ 22,500.00
302	Field locate existing utilities and service lines for construction of the proposed improvements, including related items and appurtenances, complete in place	1	LS	\$ 4,500.00	\$ 4,500.00
303	Site Clean-up, 4" topsoil, fine grading of areas disturbed by construction, including related items and appurtenances, complete in place	1	LS	\$16,000.00	\$ 16,000.00
304	SWPPP, dewatering (as required) and silt fencing (804 LF), including related items and appurtenances, complete in place	1	LS	\$25,000.00	\$ 25,000.00
305	Hydromulch Seeding, including related items and appurtenances, complete in place	1	LS	\$ 8,500.00	\$ 8,500.00
306	ROW preparing, including all earthwork, clearing and grubbing of ROW, removal of any trees in the ROW and trimming of limbs, including related items and appurtenances, complete in place	1	LS	\$38,000.00	\$ 38,000.00
307	Remove & dispose of existing guardrail and bridge rail, including related items and appurtenances, complete in place	328	LF	\$ 17.00	\$ 5,576.00
308	Remove & dispose of existing signage, including related items and appurtenances, complete in place.	4	EA	\$ 500.00	\$ 2,000.00
309	Remove & dispose of existing asphalt pavement and base, including related items and appurtenances, complete in place.	448	SY	\$ 10.00	\$ 4,480.00
310	Remove & dispose of existing chip seal/ seal coat on bridge, including related items and appurtenances, complete in place.	120	SY	\$ 25.00	\$ 3,000.00
311	General Fill to Design Grades, complete in place	50	CY	\$ 40.00	\$ 2,000.00
312	Select Fill, complete in place	50	CY	\$ 40.00	\$ 2,000.00
313	Imported Cement Stabilized Sand w/ Compaction for Roadway Construction (includes cost of Cement), (Assume 4% by weight), including related items and appurtenances, complete in place	563	SY	\$ 35.00	\$ 19,705.00
314	Type R Rock Rip Rap, 200-250lbs, Hand Placed w 6" (minimum) imported cement stabilized sand in low areas (24" Embedment) for Crossing Creek, including related items and appurtenances, complete in place	176	SY	\$ 225.00	\$ 39,600.00
315	6" concrete slope paving, including cement sand, related items and appurtenances, complete in place.	59	SY	\$ 125.00	\$ 7,375.00
316	Metal Beam Guard Fence (GF(31)-19) with GF-2 reflectors, including related items and appurtenances, complete in place	395	LF	\$ 90.00	\$ 35,550.00
317	Bridge rail, including related items and appurtenances, complete in place.	80	LF	\$ 225.00	\$ 18,000.00
318	Concrete-to-Asphalt tie-in, including related items and appurtenances, complete in place	2	EA	\$ 3,000.00	\$ 6,000.00
319	8" concrete bridge approach (Class P), including related items and appurtenances, complete in place.	563	SY	\$ 100.00	\$ 56,300.00
320	4" Thick Concrete Mow Strip (Guardrail), (GF(31)MS-19), including related items and appurtenances, complete in place	306	SY	\$ 115.00	\$ 35,190.00
321	Softstop End Terminal (50'-9.5") - SGT (10S)31-16, including related items and appurtenances, complete in place	4	EA	\$ 6,000.00	\$ 24,000.00
Collette Lane Construction Cost					\$ 397,276.00
Contingency.....					\$ 20,000.00
TOTAL OPINION OF PROBABLE CONSTRUCTION COST.....					\$ 417,276.00
Calendar Days to Completion					78

Item	Description	QTY	Unit	Unit Price	Total
Harris Lane - Bridge Scour Repair					
400	Mobilization, setup, & project overhead for duration of project, including related items and appurtenances, complete in place	1	LS	\$20,000.00	\$ 20,000.00
401	Traffic control, including Traffic Control Plans, all signage, barricades, cones, and related items and appurtenances, complete in place	1	LS	\$18,000.00	\$ 18,000.00
402	Field locate existing utilities and service lines for construction of the proposed improvements, including related items and appurtenances, complete in place	1	LS	\$ 4,500.00	\$ 4,500.00
403	Site Clean-up; 4" topsoil, fine grading of areas disturbed by construction, including related items and appurtenances, complete in place	1	LS	\$13,500.00	\$ 13,500.00
404	SWPPP, dewatering (as required) and silt fencing (964 LF), including related items and appurtenances, complete in place	1	LS	\$ 8,500.00	\$ 8,500.00
405	Hydromulch Seeding, including related items and appurtenances, complete in place	1	LS	\$ 8,500.00	\$ 8,500.00
406	ROW preparing, including all earthwork, clearing and grubbing of ROW, removal of any trees in the ROW and trimming of limbs, including related items and appurtenances, complete in place	1	LS	\$18,500.00	\$ 18,500.00
407	Remove & dispose of existing guardrail and bridge rail, including related items and appurtenances, complete in place	348	LF	\$ 17.00	\$ 5,916.00
408	Remove & dispose of existing signage, including related items and appurtenances, complete in place.	4	EA	\$ 500.00	\$ 2,000.00
409	Remove & dispose of existing asphalt pavement and base, including related items and appurtenances, complete in place.	68	SY	\$ 20.00	\$ 1,360.00
410	General Fill to Design Grades, complete in place	50	CY	\$ 40.00	\$ 2,000.00
411	Select Fill, complete in place	50	CY	\$ 40.00	\$ 2,000.00
412	Type R Rock Rip Rap, 200-250lbs, Hand Placed w 6" (minimum) imported cement stabilized sand in low areas (24" Embedment) for Crossing Creek, including related items and appurtenances, complete in place	418	SY	\$ 210.00	\$ 87,780.00
413	Metal Beam Guard Fence (GF(31)-19) with GF-2 reflectors, including related items and appurtenances, complete in place	474	LF	\$ 90.00	\$ 42,660.00
414	Bridge rail, including related items and appurtenances, complete in place.	100	LF	\$ 225.00	\$ 22,500.00
415	4" Thick Concrete Mow Strip (Guardrail), (GF(31)MS-19), including related items and appurtenances, complete in place	286	SY	\$ 115.00	\$ 32,890.00
416	Softstop End Terminal (50'-9.5') - SGT (10S)31-16, including related items and appurtenances, complete in place	4	EA	\$ 6,000.00	\$ 24,000.00
Harris Lane Construction Cost					\$ 314,606.00
Contingency					\$ 15,000.00
TOTAL OPINION OF PROBABLE CONSTRUCTION COST.....					\$ 329,606.00
Calendar Days to Completion					30

Item	Description	QTY	Unit	Unit Price	Total
Dilly Shaw Tap Road - Bridge Scour Repair					
500	Mobilization, setup, & project overhead for duration of project, including related items and appurtenances, complete in place	1	LS	\$20,000.00	\$ 20,000.00
501	Traffic control, including Traffic Control Plans, all signage, barricades, cones, and related items and appurtenances, complete in place	1	LS	\$27,500.00	\$ 27,500.00
502	Field locate existing utilities and service lines for construction of the proposed improvements, including related items and appurtenances, complete in place	1	LS	\$ 5,500.00	\$ 5,500.00
503	Site Clean-up, 4" topsoil, fine grading of areas disturbed by construction, including related items and appurtenances, complete in place	1	LS	\$18,500.00	\$ 18,500.00
504	SWPPP, dewatering (as required) and silt fencing (1,036 LF), including related items and appurtenances, complete in place	1	LS	\$11,500.00	\$ 11,500.00
505	Hydromulch Seeding, including related items and appurtenances, complete in place	1	LS	\$ 8,500.00	\$ 8,500.00
506	ROW preparing, including all earthwork, clearing and grubbing of ROW, removal of any trees in the ROW and trimming of limbs, including related items and appurtenances, complete in place	1	LS	\$18,500.00	\$ 18,500.00
507	Remove & dispose of existing guardrail and bridge rail, including related items and appurtenances, complete in place	344	LF	\$ 17.00	\$ 5,848.00
508	Remove & dispose of existing signage, including related items and appurtenances, complete in place.	6	EA	\$ 500.00	\$ 3,000.00
509	Remove & dispose of existing asphalt pavement and base, including related items and appurtenances, complete in place.	733	SY	\$ 12.00	\$ 8,796.00
510	General Fill to Design Grades, complete in place	50	CY	\$ 40.00	\$ 2,000.00
511	Select Fill, complete in place	50	CY	\$ 40.00	\$ 2,000.00
512	Imported Cement Stabilized Sand w/ Compaction for Roadway Construction (includes cost of Cement), (Assume 4% by weight), including related items and appurtenances, complete in place	741	SY	\$ 35.00	\$ 25,935.00
513	Type R Rock Rip Rap, 200-250lbs, Hand Placed w 6" (minimum) imported cement stabilized sand in low areas (24" Embedment) for Crossing Creek, including related items and appurtenances, complete in place	399	SY	\$ 210.00	\$ 83,790.00
514	Metal Beam Guard Fence (GF(31)-19) with GF-2 reflectors, including related items and appurtenances, complete in place	460	LF	\$ 90.00	\$ 41,400.00
515	Bridge rail, including related items and appurtenances, complete in place.	90	LF	\$ 225.00	\$ 20,250.00
516	Concrete-to-Asphalt tie-in, including related items and appurtenances, complete in place	2	EA	\$ 3,000.00	\$ 6,000.00
517	8" concrete bridge approach (Class P), including related items and appurtenances, complete in place.	741	SY	\$ 100.00	\$ 74,100.00
518	4" Thick Concrete Mow Strip (Guardrail), (GF(31)MS-19), including related items and appurtenances, complete in place	296	SY	\$ 115.00	\$ 34,040.00
519	Softstop End Terminal (50'-9.5") - SGT (10S)31-16, including related items and appurtenances, complete in place	4	EA	\$ 6,000.00	\$ 24,000.00
Dilly Shaw Tap Road Construction Cost					\$ 441,159.00
Contingency.....					\$ 20,000.00
TOTAL OPINION OF PROBABLE CONSTRUCTION COST.....					\$ 461,159.00
Calendar Days to Completion					78

Item	Description	QTY	Unit	Unit Price	Total
Kurten Cemetery Road - Bridge Scour Repair					
600	Mobilization, setup, & project overhead for duration of project, including related items and appurtenances, complete in place	1	LS	\$20,000.00	\$ 20,000.00
601	Traffic control, including Traffic Control Plans, all signage, barricades, cones, and related items and appurtenances, complete in place	1	LS	\$25,000.00	\$ 25,000.00
602	Field locate existing utilities and service lines for construction of the proposed improvements, including related items and appurtenances, complete in place	1	LS	\$ 4,500.00	\$ 4,500.00
603	Site Clean-up, 4" topsoil, fine grading of areas disturbed by construction, including related items and appurtenances, complete in place	1	LS	\$15,000.00	\$ 15,000.00
604	SWPPP, dewatering (as required) and silt fencing (977 LF), including related items and appurtenances, complete in place	1	LS	\$10,000.00	\$ 10,000.00
605	Hydromulch Seeding, including related items and appurtenances, complete in place	1	LS	\$ 8,500.00	\$ 8,500.00
606	ROW preparing, including all earthwork, clearing and grubbing of ROW, removal of any trees in the ROW and trimming of limbs, including related items and appurtenances, complete in place	1	LS	\$14,000.00	\$ 14,000.00
607	Remove & dispose of existing guardrail and bridge rail, including related items and appurtenances, complete in place	348	LF	\$ 18.00	\$ 6,264.00
608	Remove & dispose of existing signage, including related items and appurtenances, complete in place.	4	EA	\$ 500.00	\$ 2,000.00
609	Remove & dispose of existing asphalt pavement and base, including related items and appurtenances, complete in place.	603	SY	\$ 10.00	\$ 6,030.00
610	General Fill to Design Grades, complete in place	50	CY	\$ 40.00	\$ 2,000.00
611	Select Fill, complete in place	50	CY	\$ 40.00	\$ 2,000.00
612	Imported Cement Stabilized Sand w/ Compaction for Roadway Construction (includes cost of Cement), (Assume 4% by weight), including related items and appurtenances, complete in place	759	SY	\$ 35.00	\$ 26,565.00
613	Type R Rock Rip Rap, 200-250lbs, Hand Placed w 6" (minimum) imported cement stabilized sand in low areas (24" Embedment) for Crossing Creek, including related items and appurtenances, complete in place	659	SY	\$ 210.00	\$ 138,390.00
614	Metal Beam Guard Fence (GF(31)-19) with GF-2 reflectors, including related items and appurtenances, complete in place	500	LF	\$ 90.00	\$ 45,000.00
615	Bridge rail, including related items and appurtenances, complete in place.	150	LF	\$ 225.00	\$ 33,750.00
616	Concrete-to-Asphalt tie-in, including related items and appurtenances, complete in place	2	EA	\$ 3,000.00	\$ 6,000.00
617	8" concrete bridge approach (Class P), including related items and appurtenances, complete in place.	759	SY	\$ 100.00	\$ 75,900.00
618	4" Thick Concrete Mow Strip (Guardrail), (GF(31)MS-19), including related items and appurtenances, complete in place	306	SY	\$ 115.00	\$ 35,190.00
619	Softstop End Terminal (50'-9.5") - SGT (10S)31-16, including related items and appurtenances, complete in place	4	EA	\$ 6,000.00	\$ 24,000.00
Kurten Cemetery Road Construction Cost					\$ 500,089.00
Contingency... ..					\$ 25,000.00
TOTAL OPINION OF PROBABLE CONSTRUCTION COST.....					\$ 525,089.00
Calendar Days to Completion					78

Item	Description	QTY	Unit	Unit Price	Total
Fickey Road (001) - Bridge Scour Repair					
700	Mobilization, setup, & project overhead for duration of project, including related items and appurtenances, complete in place	1	LS	\$20,000.00	\$ 20,000.00
701	Traffic control, including Traffic Control Plans, all signage, barricades, cones, and related items and appurtenances, complete in place	1	LS	\$22,000.00	\$ 22,000.00
702	Field locate existing utilities and service lines for construction of the proposed improvements, including related items and appurtenances, complete in place	1	LS	\$ 5,500.00	\$ 5,500.00
703	Site Clean-up, 4" topsoil, fine grading of areas disturbed by construction, including related items and appurtenances, complete in place	1	LS	\$15,000.00	\$ 15,000.00
704	SWPPP, dewatering (as required) and silt fencing (821 LF), including related items and appurtenances, complete in place	1	LS	\$ 8,500.00	\$ 8,500.00
705	Hydromulch Seeding, including related items and appurtenances, complete in place	1	LS	\$ 8,500.00	\$ 8,500.00
706	ROW preparing, including all earthwork, clearing and grubbing of ROW, removal of any trees in the ROW and trimming of limbs, including related items and appurtenances, complete in place	1	LS	\$17,000.00	\$ 17,000.00
707	Remove & dispose of existing guardrail and bridge rail, including related items and appurtenances, complete in place	281	LF	\$ 18.00	\$ 5,058.00
708	Remove & dispose of existing signage, including related items and appurtenances, complete in place.	4	EA	\$ 500.00	\$ 2,000.00
709	Remove & dispose of existing asphalt pavement and base, including related items and appurtenances, complete in place.	475	SY	\$ 10.00	\$ 4,750.00
710	General Fill to Design Grades, complete in place	50	CY	\$ 40.00	\$ 2,000.00
711	Select Fill, complete in place	50	CY	\$ 40.00	\$ 2,000.00
712	Imported Cement Stabilized Sand w/ Compaction for Roadway Construction (includes cost of Cement), (Assume 4% by weight), including related items and appurtenances, complete in place	555	SY	\$ 35.00	\$ 19,425.00
713	Type R Rock Rip Rap, 200-250lbs, Hand Placed w 6" (minimum) imported cement stabilized sand in low areas (24" Embedment) for Crossing Creek, including related items and appurtenances, complete in place	249	SY	\$ 210.00	\$ 52,290.00
714	Metal Beam Guard Fence (GF(31)-19) with GF-2 reflectors, including related items and appurtenances, complete in place	394	LF	\$ 90.00	\$ 35,460.00
715	Bridge rail, including related items and appurtenances, complete in place.	80	LF	\$ 225.00	\$ 18,000.00
716	Concrete-to-Asphalt tie-in, including related items and appurtenances, complete in place	2	EA	\$ 3,000.00	\$ 6,000.00
717	8" concrete bridge approach (Class P), including related items and appurtenances, complete in place.	555	SY	\$ 100.00	\$ 55,500.00
718	4" Thick Concrete Mow Strip (Guardrail), (GF(31)MS-19), including related items and appurtenances, complete in place	292	SY	\$ 115.00	\$ 33,580.00
719	Softstop End Terminal (50'-9.5") - SGT (10S)31-16, including related items and appurtenances, complete in place	4	EA	\$ 6,000.00	\$ 24,000.00
Fickey Road (001) Construction Cost					\$ 356,563.00
Contingency.....					\$ 20,000.00
TOTAL OPINION OF PROBABLE CONSTRUCTION COST.....					\$ 376,563.00
Calendar Days to Completion					78

Item	Description	QTY	Unit	Unit Price	Total
Fickey Road (002) - Bridge Scour Repair					
800	Mobilization, setup, & project overhead for duration of project, including related items and appurtenances, complete in place	1	LS	\$20,000.00	\$ 20,000.00
801	Traffic control, including Traffic Control Plans, all signage, barricades, cones, and related items and appurtenances, complete in place	1	LS	\$22,000.00	\$ 22,000.00
802	Field locate existing utilities and service lines for construction of the proposed improvements, including related items and appurtenances, complete in place	1	LS	\$ 4,500.00	\$ 4,500.00
803	Site Clean-up, 4" topsoil, fine grading of areas disturbed by construction, including related items and appurtenances, complete in place	1	LS	\$18,000.00	\$ 18,000.00
804	SWPPP, dewatering (as required) and silt fencing (824 LF), including related items and appurtenances, complete in place	1	LS	\$10,000.00	\$ 10,000.00
805	Hydromulch Seeding, including related items and appurtenances, complete in place	1	LS	\$ 8,500.00	\$ 8,500.00
806	ROW preparing, including all earthwork, clearing and grubbing of ROW, removal of any trees in the ROW and trimming of limbs, including related items and appurtenances, complete in place	1	LS	\$20,000.00	\$ 20,000.00
807	Remove & dispose of existing guardrail and bridge rail, including related items and appurtenances, complete in place	396	LF	\$ 18.00	\$ 7,128.00
808	Remove & dispose of existing signage, including related items and appurtenances, complete in place.	6	EA	\$ 500.00	\$ 3,000.00
809	Remove & dispose of existing asphalt pavement and base, including related items and appurtenances, complete in place.	465	SY	\$ 10.00	\$ 4,650.00
810	General Fill to Design Grades, complete in place	50	CY	\$ 40.00	\$ 2,000.00
811	Select Fill, complete in place	50	CY	\$ 40.00	\$ 2,000.00
812	Imported Cement Stabilized Sand w/ Compaction for Roadway Construction (includes cost of Cement), (Assume 4% by weight), including related items and appurtenances, complete in place	646	SY	\$ 35.00	\$ 22,610.00
813	Type R Rock Rip Rap, 200-250lbs, Hand Placed w 6" (minimum) imported cement stabilized sand in low areas (24" Embedment) for Crossing Creek, including related items and appurtenances, complete in place	340	SY	\$ 210.00	\$ 71,400.00
814	6" concrete slope paving, including cement sand, related items and appurtenances, complete in place.	82	SY	\$ 170.00	\$ 13,940.00
815	Metal Beam Guard Fence (GF(31)-19) with GF-2 reflectors, including related items and appurtenances, complete in place	367	LF	\$ 90.00	\$ 33,030.00
816	Bridge rail, including related items and appurtenances, complete in place.	120	LF	\$ 225.00	\$ 27,000.00
817	Concrete-to-Asphalt tie-in, including related items and appurtenances, complete in place	2	EA	\$ 3,000.00	\$ 6,000.00
818	8" concrete bridge approach (Class P), including related items and appurtenances, complete in place.	646	SY	\$ 100.00	\$ 64,600.00
819	4" Thick Concrete Mow Strip (Guardrail), (GF(31)MS-19), including related items and appurtenances, complete in place	263	SY	\$ 115.00	\$ 30,245.00
820	Softstop End Terminal (50'-9.5") - SGT (10S)31-16, including related items and appurtenances, complete in place	4	EA	\$ 6,000.00	\$ 24,000.00
Fickey Road (002) Construction Cost					\$ 414,603.00
Contingency... ..					\$ 20,000.00
TOTAL OPINION OF PROBABLE CONSTRUCTION COST.....					\$ 434,603.00
Calendar Days to Completion					78

Item	Description	QTY	Unit	Unit Price	Total
Deep Well Road - Bridge Scour Repair					
900	Mobilization, setup, & project overhead for duration of project, including related items and appurtenances, complete in place	1	LS	\$20,000.00	\$ 20,000.00
901	Traffic control, including Traffic Control Plans, all signage, barricades, cones, and related items and appurtenances, complete in place	1	LS	\$16,000.00	\$ 16,000.00
902	Field locate existing utilities and service lines for construction of the proposed improvements, including related items and appurtenances, complete in place	1	LS	\$ 4,500.00	\$ 4,500.00
903	Site Clean-up, 4" topsoil, fine grading of areas disturbed by construction, including related items and appurtenances, complete in place	1	LS	\$16,500.00	\$ 16,500.00
904	SWPPP, dewatering (as required) and silt fencing (685 LF), including related items and appurtenances, complete in place	1	LS	\$ 8,850.00	\$ 8,850.00
905	Hydromulch Seeding, including related items and appurtenances, complete in place	1	LS	\$ 8,500.00	\$ 8,500.00
906	ROW preparing, including all earthwork, clearing and grubbing of ROW, removal of any trees in the ROW and trimming of limbs, including related items and appurtenances, complete in place	1	LS	\$14,000.00	\$ 14,000.00
907	Remove & dispose of existing guardrail and bridge rail, including related items and appurtenances, complete in place	305	LF	\$ 18.00	\$ 5,490.00
908	Remove & dispose of existing wood in existing channel and cut piles below finished grade, including related items and appurtenances, complete in place	1	LS	\$ 7,500.00	\$ 7,500.00
909	Remove & dispose of existing signage, including related items and appurtenances, complete in place.	4	EA	\$ 500.00	\$ 2,000.00
910	General Fill to Design Grades, complete in place	50	CY	\$ 40.00	\$ 2,000.00
911	Select Fill, complete in place	50	CY	\$ 40.00	\$ 2,000.00
912	Type R Rock Rip Rap, 200-250lbs, Hand Placed w 6" (minimum) imported cement stabilized sand in low areas (24" Embedment) for Crossing Creek, including related items and appurtenances, complete in place	243	SY	\$ 210.00	\$ 51,030.00
913	Metal Beam Guard Fence (GF(31)-19) with GF-2 reflectors, including related items and appurtenances, complete in place	270	LF	\$ 90.00	\$ 24,300.00
914	Bridge rail, including related items and appurtenances, complete in place.	80	LF	\$ 225.00	\$ 18,000.00
915	4" Thick Concrete Mow Strip (Guardrail), (GF(31)MS-19), including related items and appurtenances, complete in place	203	SY	\$ 115.00	\$ 23,345.00
916	Softstop End Terminal (50'-9.5") - SGT (10S)31-16, including related items and appurtenances, complete in place	4	EA	\$ 6,000.00	\$ 24,000.00
Deep Well Road Construction Cost					\$ 248,015.00
Contingency... ..					\$ 10,000.00
TOTAL OPINION OF PROBABLE CONSTRUCTION COST...					\$ 258,015.00
Calendar Days to Completion					30

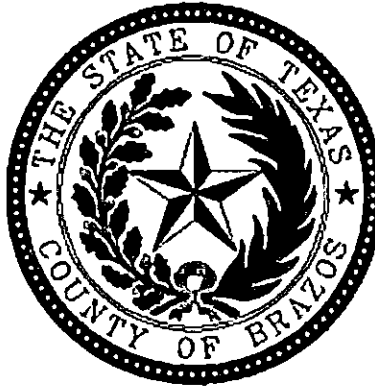

REQUEST FOR PROPOSALS

RFP NO. CIP 25-583

Brazos County Bridge Scour Repair

**SEALED PROPOSALS TO BE SUBMITTED BEFORE:
Tuesday, August 19, 2025, 2:00pm CST**

**TO THE:
BRAZOS COUNTY
PURCHASING DEPARTMENT
200 S. Texas Ave. Suite 352
Bryan, TX 77803
Phone: (979) 361-4290
Fax: (979) 361-4293**

Respondents, their employees and/or representatives are prohibited from contacting any official or employee of Brazos County, except the Purchasing Agent, regarding this solicitation from the issuing date of the solicitation until scheduled oral presentations or the date the Brazos County Commissioners Court meets to consider award of the RFP. Any such contact will be grounds for rejection of the respondents' proposal.

In compliance with this solicitation, the undersigned proposer having examined the solicitation and specifications and being familiar with the conditions to be met, hereby submits the following RFP for furnishing the material and/or services listed on the attached bid form and agrees to deliver said items at the locations and for the prices set forth on the bid form.

Company Name: Solid Bridge Construction

By (Print): Travis Hanus Title: Travis Hanus, Vice President

Physical Address: 3104 Interstate 45 South New Waverly, TX 77358

Mailing Address: 3104 Interstate 45 South New Waverly, TX 77358

Telephone: 936-435-0700 Fax: none E-Mail: travis@solidbridgeconstruction.com

7. By submitting a response to this RFP, the proposer is agreeing to sign the County's Contract, Exhibit C attached.
8. **The following items should be completed and included in your proposal submission. Failure to include these items will disqualify your proposal.**
- a. **Completed and signed RFP including:**
 - i. **References (Section R)**
 - ii. **Certification of Proposal (Section U)**
 - b. **Bid Bonds**
 - c. **Exhibit B – Bid Form**
 - d. **A-305 Qualifications Statement or similar**
 - e. **Proposed Project Schedule**

R. PRICING

Complete Exhibit B attached and submitted with the proposal.

S. REFERENCES

Respondents shall provide a list of at least five (5) references, where work comparable in quality and scope to that specified has been performed within the past five (5) years. This list should include the **names, phone number and email** of the company/entity for which the prior work was performed to contact these references. References received on previous solicitations for similar size and scope in the previous six (6) months may be considered in lieu of obtaining a new reference check. A negative reference may be grounds for disqualification of bid. Respondents are not allowed to use Brazos County as a reference.

Company/Entity: Walker County

Contact: Bill Daugette

Phone: 936-436-4912

Email: bdaugette@co.walker.tx.us

Company/Entity: ELS

Contact: Michael Hoffman

Phone: 480-761-6373

Email: Michael_Hoffman@equitylifestyle.com

Company/Entity: Bleyl Engineering

Contact: Ken Walker

Phone: 936-441-7833

Email: KWalker@bleylengineering.com

[Redacted]

Company/Entity: City of Shenandoah

Contact: Rual Porras

Phone: (281) 298-5522

Email: rporras@shenandoahtx.us

[Redacted]

Company/Entity: Prime Contractors, Inc.

Contact: Jakob Barnes

Phone: 281.999.0875

Email: jbarnes@primecontractorsinc.com

Additional:

City of Huntsville

Trey Marek

936-294-5779

rmarek@huntsvilletx.gov

T. PROPOSAL EVALUATION WAIVER

By submitting a proposal or response, each Proposer/offeror indicated below agrees to waive any claim it has or may have against Brazos County (the Owner), Architect, Engineers, Consultants and their respective Commissioners, directors, employees, or agents arising out of or in connection with (1) the administration, evaluation, or recommendation of any proposal or response (2) any requirement under the Request for Proposal or related documents; (3) the rejection of any proposal or response or any part of any proposal or response; and/or (4) the award of a Contract, if any.

The Proposer further agrees the Owner reserves the right to waive any requirements under the proposal documents or the Contract Documents, with regards to acceptance or rejection of any proposals, and recommendation or award of the contract.

Note: The Statement of Affirmation Must be Notarized.

STATEMENT OF AFFIRMATION

The undersigned affirms that he/she is duly authorized to execute this waiver by the person(s) or business entity making the proposal.

Firm's Name: Solid Bridge Construction

Address: 3104 Interstate 45 South New Waverly, TX 77358

Proposer's Name: Travis Hanus

Position/Title: Vice President

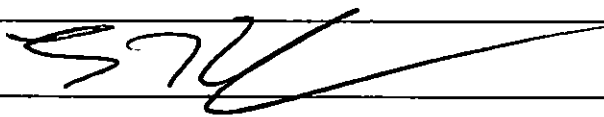
Proposer's Signature: 

Date: 8/18/2025

Subscribed and sworn to me on this 18th day of August in the year 2025

Notary Public

My Commission expires 2-10-2029

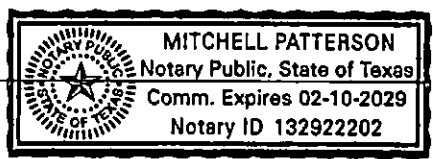

U. ADDENDA

The undersigned acknowledges responsibility for all addenda issued prior to closing date. No addenda will be issued less than 48 hours prior to the solicitation submission deadline.

No. #1 No. _____ No. _____

Date 8-11-2025 Date _____ Date _____

V. CERTIFICATION OF PROPOSAL

The undersigned affirms that they are duly authorized to execute this contract, that this proposal has not been prepared in collusion with any other Contractor, and that the contents of this proposal have not been communicated to any other Contractor prior to the official opening.

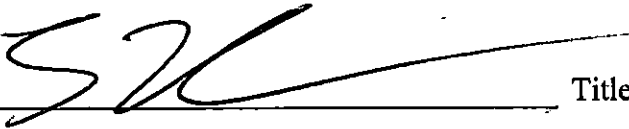
Signed By:  Title: Vice President

Typed Name: Travis Hanus

Company Name: Solid Bridge Construction

Mailing Address: 3104 Interstate 45 South New Waverly TX 77358
P.O. Box or Street City State Zip

Employer Identification Number: 81-0625605

CORPORATE SEAL IF SUBMITTED BY A CORPORATION
END OF RFP NO. CIP 25-583

By signing below, Brazos County agrees that this RFP CIP 25-583 will be awarded to the respondent whose name appears above, and both parties agree to the terms and conditions contained herein.

By: Brazos County Commissioner's Court 

Date: September 23, 2025

Attest: Brazos County Clerk 

Point of Contact: Travis Hanus

Address: 3104 Interstate 45 South, New Waverly, TX 77358

936-435-0700

office@solidbridgeconstruction.com

Form of Business: Corporation

State of Registration: Texas

Years in Existence: 21 years

Team Structure (for this project):

Owner and President of Solid Bridge Construction: Vance Bridges

Project Manager/Vice President: Travis Hanus

- **Bachelor's Degree in Business Administration from Sam Houston State University**
- **5 years as Superintendent for Solid Bridge Construction**
- **6 years as Vice President and Project Manager for Solid Bridge Construction**
- **11 years as chief estimator for Solid Bridge Construction**

Superintendent: Mitchel McMillian

- **Bachelor's Degree in from Sam Houston State University**
- **8 years as Superintendent and Project Manager for Solid Bridge Construction**
- **Over 55 construction projects completed in career.**

Superintendent: Skyler Jankowiak

- **Bachelor's Degree in Industrial Distribution and Engineering, Texas A&M**
- **8 years as Superintendent and Project Manager for Solid Bridge Construction**
- **4 years as Project Engineer for Kiewit**
- **Over 50 construction projects completed in career.**

Assistant Project Manager: Mitchell Patterson

- **Bachelor's Degree in Finance from University of Mary Hardin-Baylor**
- **4 years as Estimator, Assistant Project Manager and Contract Administrator for Solid Bridge Construction**

SOLID BRIDGE CONSTRUCTION

3104 Interstate-45 South
New Waverly Tx 77358

936-435-0700

Years of
Experience in
Civil Years With
Solid Bridge

Office Staff			
President	Vance Bridges	26	24
Vice President	Travis Hanus	14	12
Controller	Clay Collins	7	4
Office Manager	Mitch Patterson	5	3
Project Manger	Carl Franzen	30	13
Project Manger	Skyler Jankowiak	12	8
Project Manger	Mitch McMillian	9	8
Project Manger	Codey Westin	7	7
Project Manger	Shea Aucoin	12	3

Equipment Management			
Fleet Manager	David Castillo	34	4
Lead Equipment Mechanic	Rafael Garcia	15	6
General Mechanic	Charles Fox	42	3
Haul Truck Operator	Robert Jackson	23	2

Field Management			
Supernatant	Antwain Evans	15	8
Supernatant	Jesus Ortega	11	11
Supernatant	Luis Ortega	11	9
Foreman	Alexis Berber	10	7
Foreman	Brijido Borunda	32	4
Foreman	Juan Avila	8	6

SOLID BRIDGE CONSTRUCTION

:1104 Interstate-45 South
New Waverly Tx 77358

936-435-0700

Field Crews			
Operator	Obed Benitez	34	5
Operator	Esau Chaverria	32	5
Operator	Lazaro Corrales	29	1
Operator	Taylor Ford	3	3
Operator	Jose Delgado	17	5
Operator	Elmer Maradiaga	24	3
Operator	Noe Mejia	27	5
Operator	Josue Mejivar	23	5
Operator	Lionel Montoya	19	3
Operator	Jose Ortiz	21	4
Operator	Victor Ruiz	16	2
Operator	Ryan Westcott	21	9
Operator	Jose Zalar	19	3
Operator	Erick Vargas	7	1
Operator	Juan Vaquera	33	5

Field Crews			
General Construction	Luis Aguirre	15	7
General Construction	Wilfredo Aviles	21	4
General Construction	Rogelio Ayala	27	3
General Construction	Jose Chavarria	31	5
General Construction	Rogelio Ayala	16	5
General Construction	Alvaro Contreras	36	6
General Construction	Christopher Cooper	11	3
General Construction	Cristhian Espinoza	9	3
General Construction	Efren Galven	34	8
General Construction	Manuel Herrera	15	2
General Construction	Chase Maxey	6	1
General Construction	Jose Leija	22	5
General Construction	Bryan Perez	4	1
General Construction	RonalRodas	11	4
General Construction	Kenner Lopez	3	1
General Construction	Rita Silva	34	10
General Construction	Pablo Vazquez	9	4

STATEMENT OF BIDDER'S QUALIFICATIONS

All questions must be answered and the data given must be clear and comprehensive. **This statement must be notarized.** If necessary, questions may be answered on separate attached sheets. The Bidder may submit any additional information it desires.

Date: 8/18/2025

Bidder (Legal Name of Firm): Solid Bridge Construction

Date Organized: 7/23/2003

Name of Owner(s): Vance Bridges

Address: 3104 Interstate 45 South
New Waverly, TX 77358

Date Incorporated: 7-23-2003

Federal ID Number: 81-0625605

Number of Years in contracting business under present name: 22 years

List all other names under which your business has operated in the last 10 years:
n/a

Work Presently Under Contract:

Contract	Amount \$	Completion Date
GT Bars	\$4,590,119.70	October 2025
Leonard Road Stabilization	\$1,642,043.50	September 2025
Livingston Dam Repairs	\$387,050	August 2025

Type of work performed by your company: civil construction

Total Staff employed by Firm (Breakdown by Managers and Trades on separate sheet): 45 field
2 office staff
6 project managers

Have you ever failed to complete any work awarded to you? Yes X No
(If yes, please attach summary of details on a separate sheet. Include brief explanation of cause and resolution)

Have you ever defaulted on a contract? Yes X No
(If yes, please attach summary of details on a separate sheet.)

Has your organization had any disbarments or suspensions that have been imposed in the past five (5) years or that was still in effect during the five-year period or is still in effect? Yes X No
(If yes, list and explain; such list must include disbarments and suspensions of officers, principals, partners, members, and employees of your organization.) List on a separate sheet.

List the projects most recently completed by your firm (include project of similar importance):

Project	Amount \$	Mo/Yr Completed
Jasper Sandy Creek Bank	\$1,114,548	July 2024
GLO City of Rockdale Drainage Improvements	\$3,472,466	November 2024
TXCDBG Brenham Street and Drainage Improvements	\$567,979	October 2024

Major equipment available for this contract: (if needed list on separate sheet)

see attached

Are you in compliance with all applicable EEO requirements?
(If no, please attach summary of details on a separate sheet.)

Yes No

(Optional) Minority Business Reporting Information

Owner's Race: _____ Owner's Ethnicity: _____ Owner's Gender: _____

Are you a Section 3 business? (see below)

Yes No

Section 3 Business Concerns:

- a) Businesses that are 51 percent or more owned by Section 3 residents;
- b) Businesses whose permanent, full-time employees include persons, at least 30 percent of whom are currently Section 3 residents, or within three years of the date of first employment with the firm were Section 3 residents;
- c) Businesses that provide evidence of a commitment to subcontract in excess of 25 percent of the dollar amount of all subcontracts to be awarded to businesses that meet the qualifications described above; or
- d) Businesses located within the City/County's jurisdiction that identifies themselves as Section 3 Business Concerns because they provide economic opportunities for low- and very low-income persons.

Bank References: NewFirst National Bank Credit Available: \$10,000,000

Contact Name: Veronica Wesneski Phone Number: 832-344-2051

Address: 16554 Creekbend Drive, Suite 150

City State & Zip Sugar Land, Texas 77478

Has the firm or predecessor firm been involved in a bankruptcy or reorganization?
(If yes, please attach summary of details on a separate sheet.)

Yes No

List on a sheet attached hereto all judgements, claims, arbitration proceedings, or suits pending or outstanding against bidder over the last five (5) years with amount of claim and brief description.

List on a sheet attached hereto all lawsuits or requested arbitration with regard to construction contracts which bidder has initiated within the last five (5) years and brief explanation of claim and outcome.

Attach résumé(s) for the principal member(s) of your organization, including the officers as well as the proposed superintendent for the project.

The undersigned hereby authorizes and requests any person, firm, or corporation to furnish any information requested by City in verification of the recitals comprising this Statement of Bidder's Qualifications.

Signed this 18th day of August, 2025.

Signature:

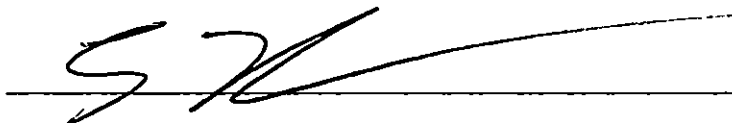

Printed Name:

Travis Hanus

Title:

Vice President

Company Name:

Solid Bridge Construction

Notary Statement:

Travis Hanus, VP, being duly sworn, says that he/she is the Travis Hanus, VP Position/Title of Solid Bridge Construction (Firm Name), and hereby swears that the answers to the foregoing questions and all statements therein contained are true and correct. He/she hereby authorizes and requests any person, firm, or corporation to furnish any information requested City of Rosenberg in verification of the recitals comprising this Statement of Bidder's Qualifications.

Subscribed and sworn before me this 18th day of August, 2025.

Notary Public

Signature:



Printed Name:

Mitchell Patterson

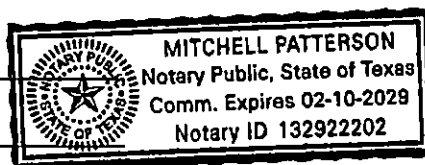

My Commission Expires: 2-10-2029

The penalty for making false statements is prescribed in the U. S. Criminal Code, 18 U.S.C. 1001.

Recent Public Projects & References



3104 Interstate 45 South
New Waverly, TX 77358
936-435-0700

Brazos River Stabilization

Owner: Fort Bend County Mud NO. 140
Agency: US Army Corps of Engineers, Funded by NRCS,
FEMA, Army Corps, Texas Historical Commission, Brazos
River Authority, Fort Bend County Flood Control
Engineer: Costello, Inc., Ron Dechert, 713-783-7788

Amount	\$6,720,400
Date Completed	4/30/2021
Duration	7 months

- Emergency stream bank stabilization of the Brazos River
- 68,000 tons of rip rap , 1 mile of bank stabilization
- Texas Historical battle site within construction boundaries. We recognized the on-site monitoring needed for the VCWRF Biosolids Facility project
- 180 day contract substantially completed in 105 days

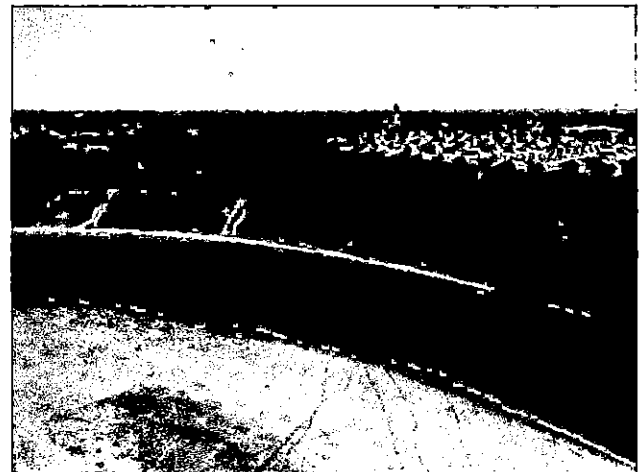

Brazos County Bridge Scour Repair

Owner: Brazos County,
William Hadley,
whadley@brazoscountytexas.gov
Engineer: G.L.S.
Mason Kwiatkoski, 979-776-9700

Amount	\$1,677,208.90
Date Completed	12/2024
Duration	4 months

- Roadway Stabilization
- Riprap
- Erosion Control
- Guard Rail

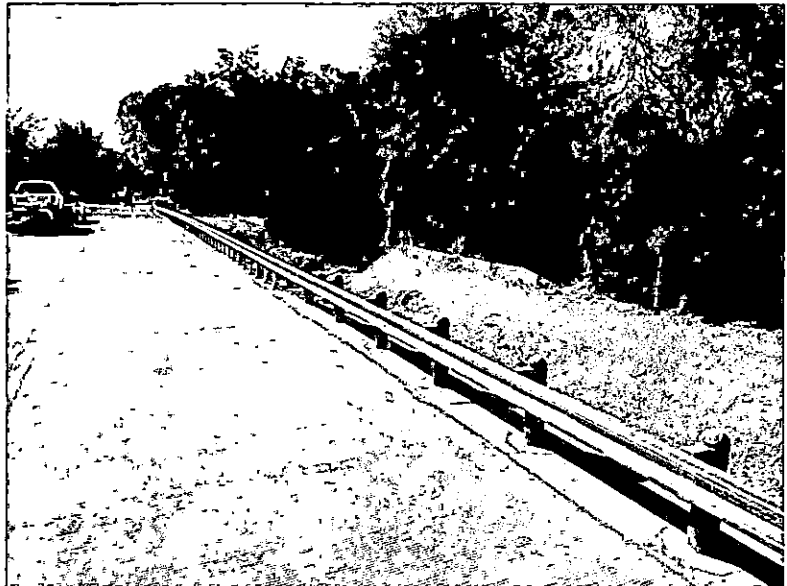
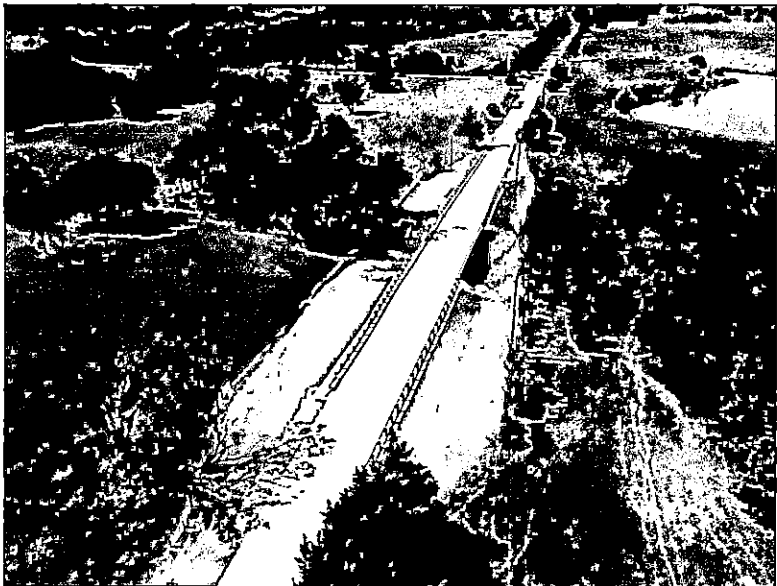

Trinity River Lock & Dam No. 7

Owner: North Texas Municipal Water District
Rodney Wolfe— NTMWD Construction
Inspector 2, 469-652-9809,
rwolfe@ntmwd.com
Engineer: Freese and Nichols, Mark Ickert,
817-735-7229

Amount
Date Completed
Duration

\$6,248,530
7/2023
16 months

- MSE soil stabilization bags with bare root saplings and native grass germination
- Temp irrigation
- Deep riverine environment
- 38,000 tons of stone rip rap

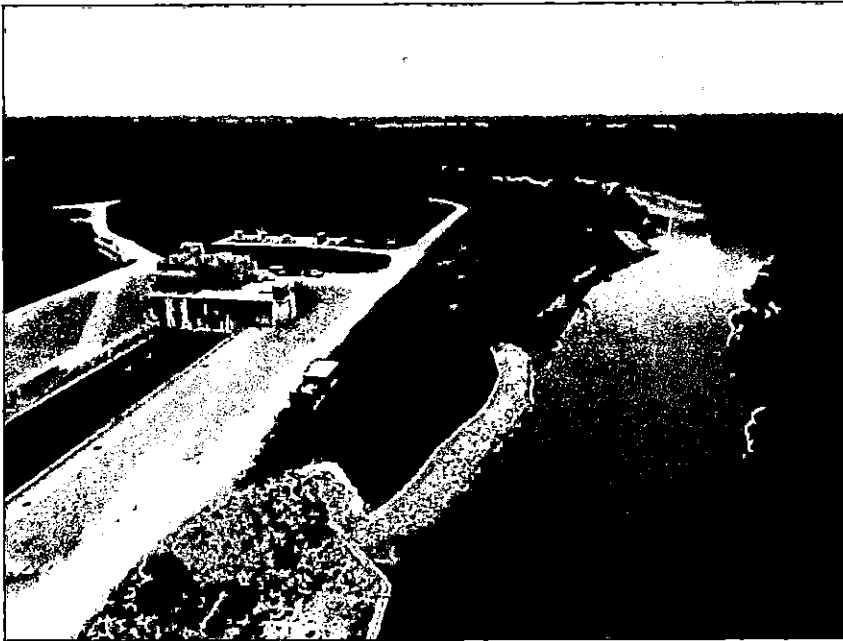

Rayford Crossing RV

Owner: MHC Land Holdings LLC
8350 E Raintree Suite 220
Scottsdale, AZ 85260
512-541-0041
Engineer: Vogt Engineering, L.P., Sergio
Van Dusen, 281-651-2976

Amount \$6,220,398.55
Date Completed January 2023

A 175 Unit RV Park that encompasses retaining walls, flat work, electrical design and installation, lift stations with a design build landscape package in Spring, Texas turned out to be a large and beautiful project for Soid Bridge. We are currently working with the owners on planning and development for an RV park with design build amenity center and small water park on lake Conroe in Willis Texas with a start date of June 1, 2024.

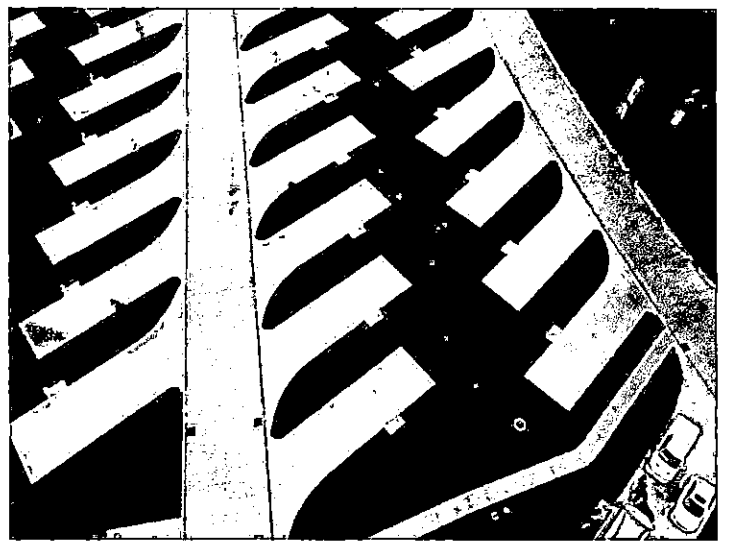

Thousand Trails Colorado River RV

**Amount
Date Completed**

**\$4,614,492.29
February 2022**

Owner: MHC TT, L.P. - C/O Equity LifeStyle Properties, Inc.
8350 E Raintree Suite 220 Scottsdale, AZ 85260
Luis Gonzalez – 480-589-5620
Engineer: Kimley-HornColton Morgan, P.E.
(281) 475-2819

- 100 unit RV park expansion
- Large cut and fills to balance site
- Sealed existing amenity lake
- Job was completed in 180 days
- Installed on-site sewer system

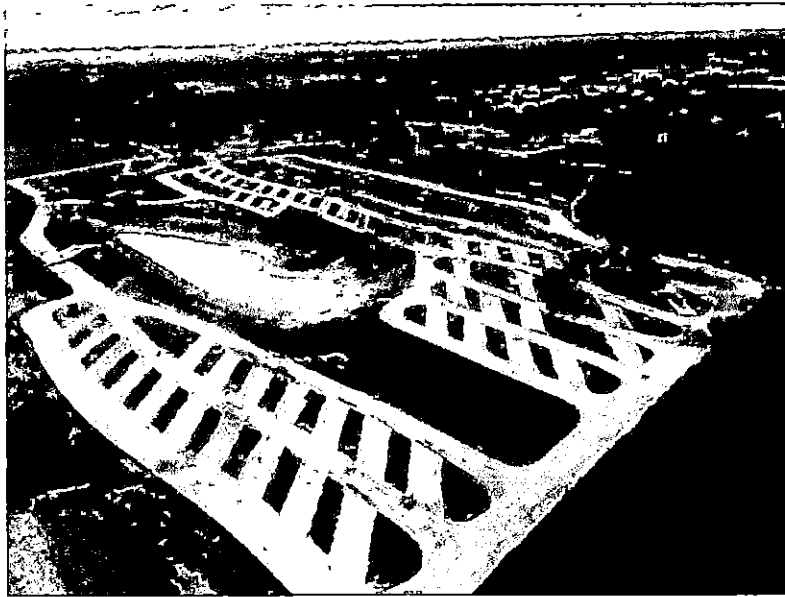

Artavia Astaire Parkway Culvert Bridge

Owner: Airia Development Co. and
MCMUD 111

20333 State Highway 249, Suite 600
Houston, Texas 77070
(281) 809-7800

Engineer: LJA Engineering, Inc.,
Christopher LeBlanc, 713-953-5200

Amount

\$1,865,112.70

Date Completed

November 2023

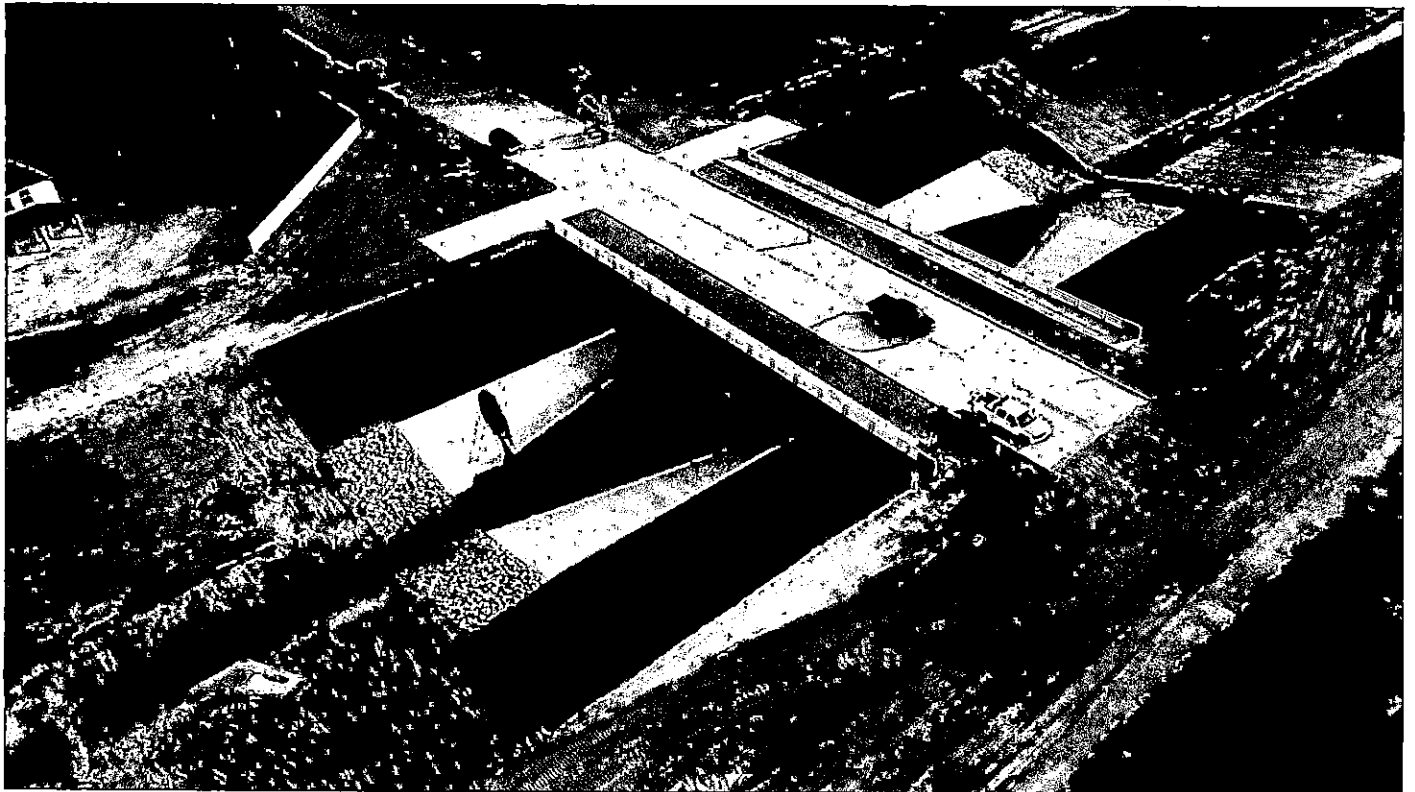
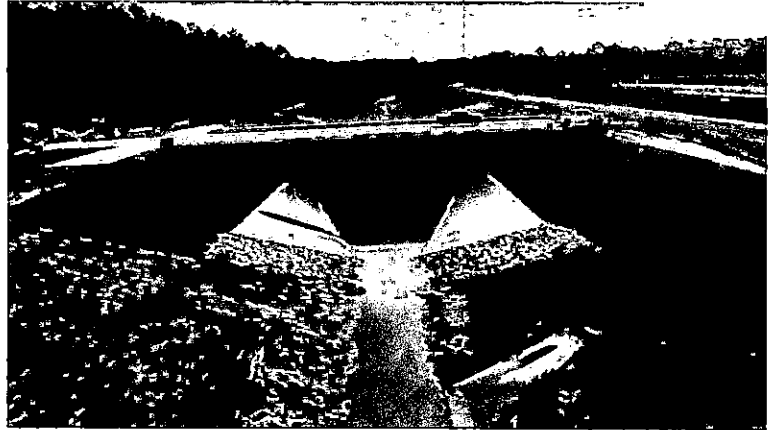
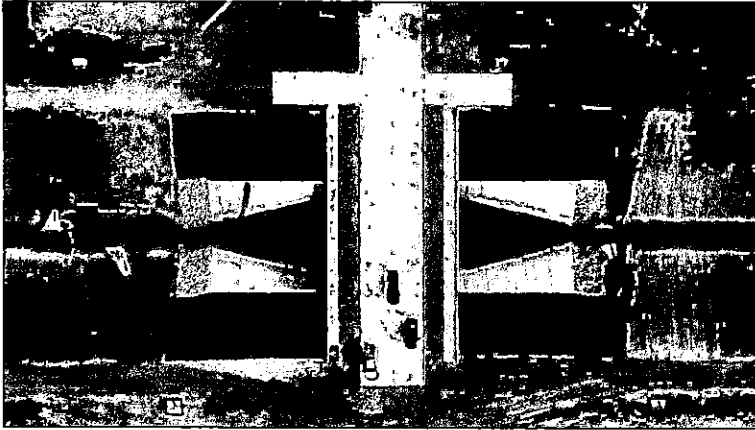

City of Brenham WWTP Bank Stabilization

Dane Rau
200 W Vulcan Street
Brenham, Texas
Cell - 979-451-1786
drau@cityofbrenham.org

Amount \$1,700,000
Date Completed 6/2019
Duration 7 Months

- 350 liner feet of 60'-0" sheet pile in bank with confined working area
- 1500 tons of rip rap installed in wall protection
- Storm lines in highly regulated area with gas and chemical lines



Atkins Creek Water, Sanitary and Storm
Owner: City of Montgomery, Mike Muckleroy,
mmuckleroy@ci.montgomery.tx.us,
936-521-5294
Engineer: Jones | Carter,
Michael Carpenter, 713-569-4197

Amount	\$321,592.40
Date Completed	2/2020
Duration	2 months

- Pile Driving
- Water and Sewerline
- Relocating 42" SET
- Removal of 60' Pipe

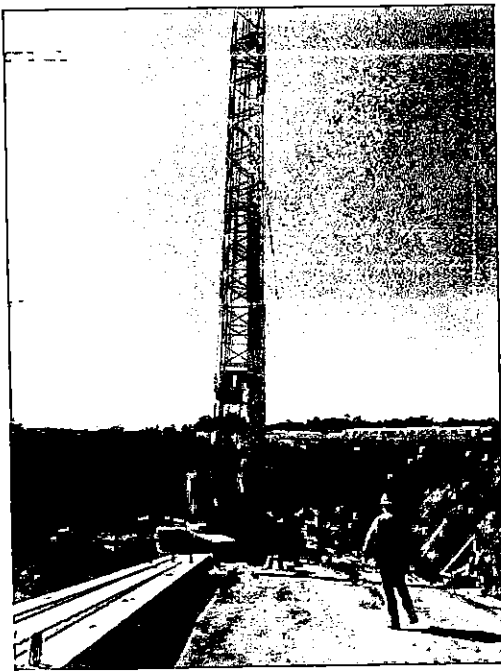

Sachse - Third Garland Creek Stabilization
Owner: City of Sachse, Corey Nesbit
469-429-4792, cnesbit@cityofsachse.com
Engineer: LJA Engineering, Dallas Wendling,
214-620-2772

Amount	\$1,652,925
Date Completed	9/2024
Duration	6 months

- Sheet Piling
- Sewerline Protection
- Erosion Control

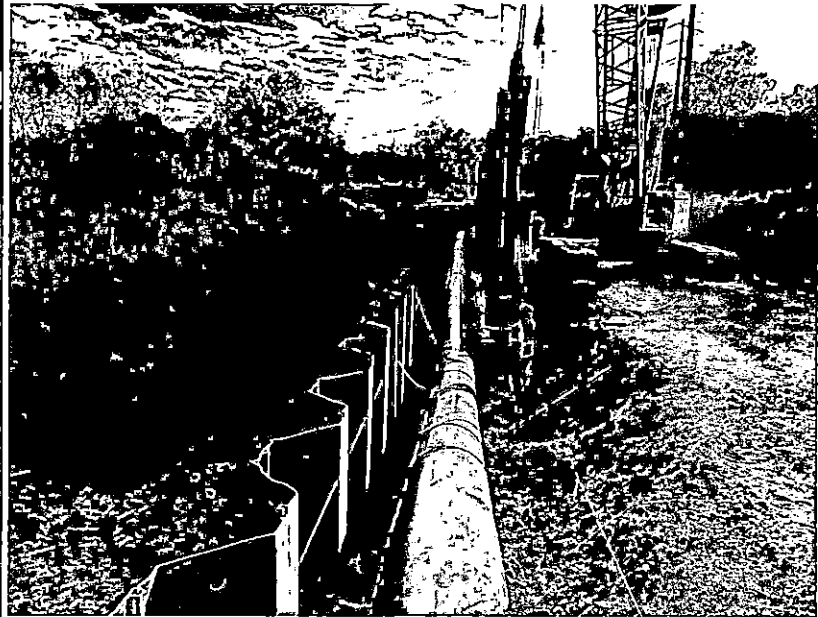
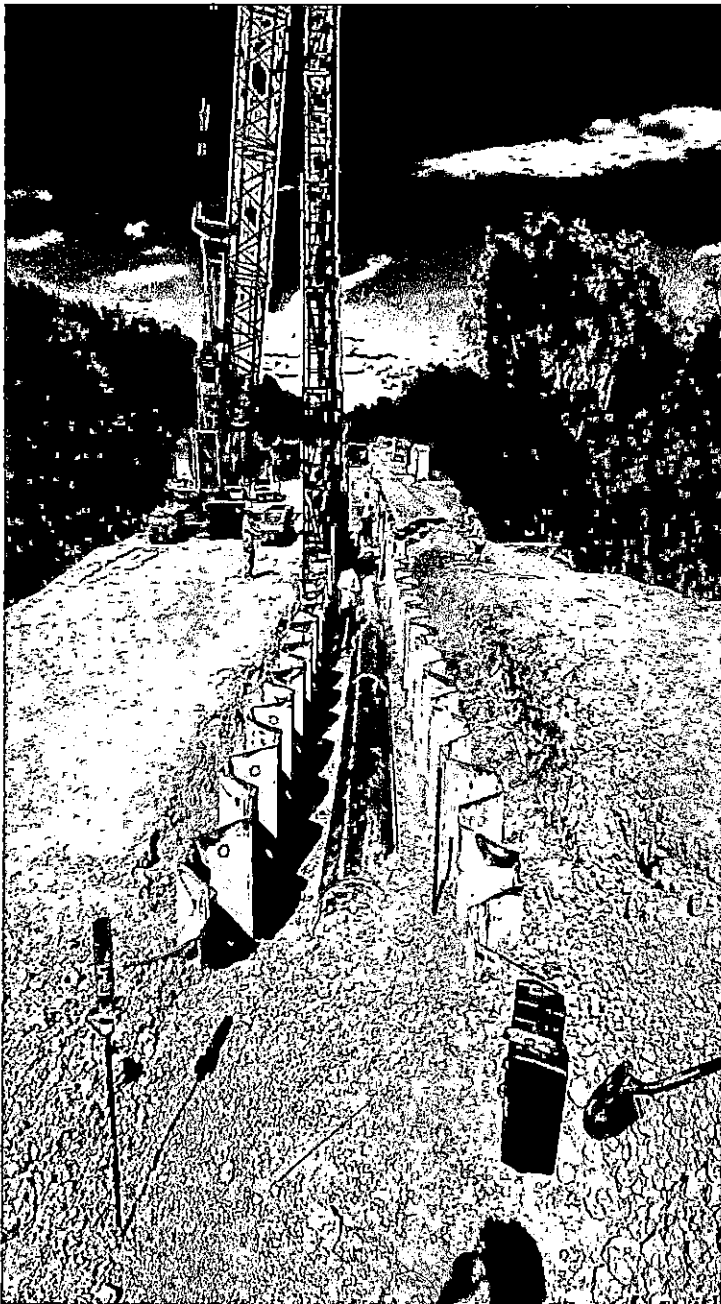

Lake O' The Pines Raw Water Intake Repairs

KSA Engineers
Dennis Cole
140 E Tyler Street Suite 600
Longview, TX 75601
713-819-8282
dcole@ksaeng.com

Amount	\$1,750,000
Date Completed	6/2020
Duration	8 Months

- Repairs and improvements to the Longview Water Plant
- Installation of sheetpile below water level
- Installation of rip-rap below water level
- Diver used to set grades and survey locations
- Eagles nest in area required classes and heavy regulations

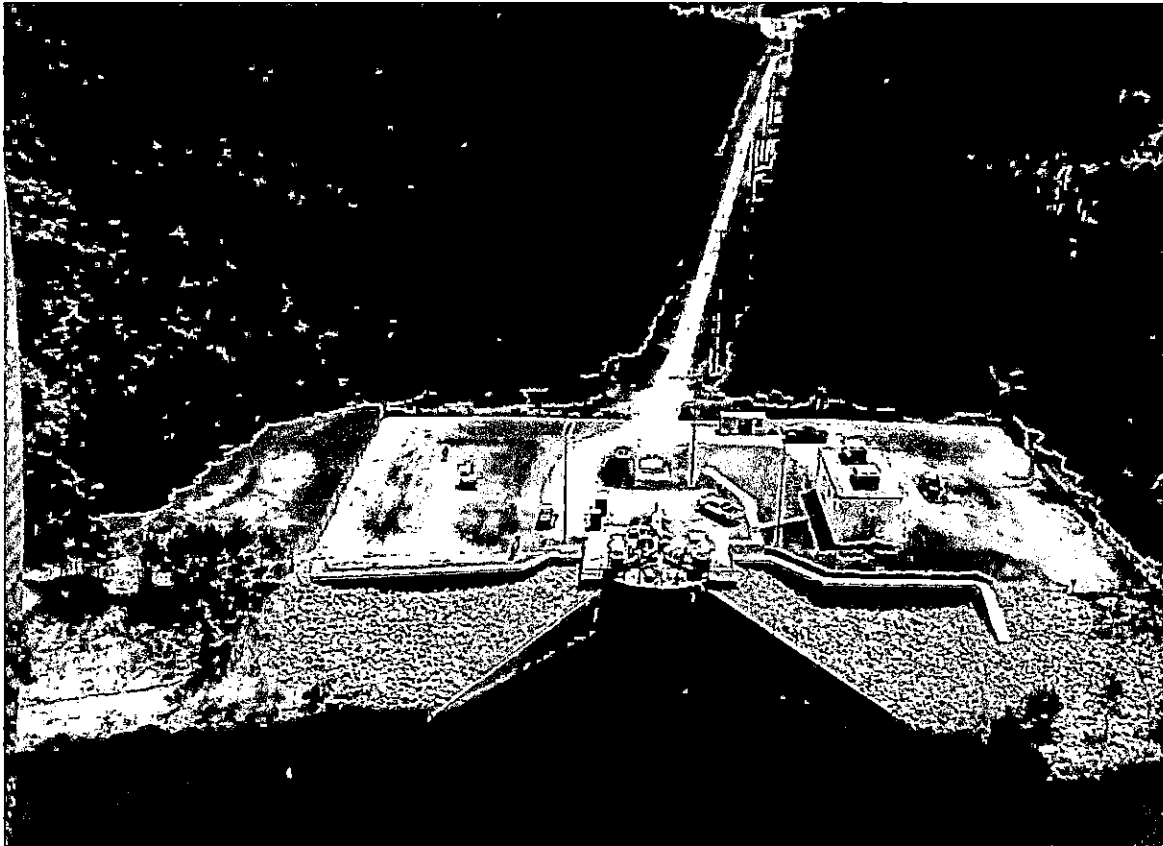

Lynn Creek Park

Owner: The City of Grand Prairie,
Romin A. Khavari
Engineer: Half Associates Inc.
Stephen Crawford

Amount
Date Completed
Duration

\$400,841
11/2020
4 months

- Sheet Piling with Tiebacks
- Shoreline Protection
- Riprap



Walker County Box Culvert Crossing

Bill Dauge - Commissioner Precinct 3
1100 University Ave Room 205
Huntsville, TX 77340
Office - 936-436-4912

Amount \$450,000
Date Completed 10/2019
Duration 5 Months

2 - 8'X8' box culvert crossing of county roads

- traffic control while construction
- txdot rated headwalls and slope paving
- care of water during construction process



Polk County Trinity River Erosion

Owner: Polk County, 101 West Church Street,
Suite 300 Livingston, TX 77351
936-327-6813
Agency: NRCS
Engineer: GLS, 903-581-3805

Amount \$468,000
Date Completed 2/2020
Duration 4 Months

- Limited workspace on top of bank
- Emergency stabilization of the Trinity River in Polk County
- Steep Riverine Environment
- Rapid Water level changes below TRA Livingston Dam



KSA - Engineers - Tyler Texas

Chris Aylor - KSA Engineers Senior Project Manager
Office - 903 - 581 - 8141
Cell - 903 - 452 - 4880
Dennis Cole - Project Representative
Cell - 713 - 819 - 8282
6781 Oak Hill Boulevard
Tyler, TX 75703

Amount 1,700,000
Date 5/1/2017
Duration 10 Months

Ashmore Drainage Improvements
- complex concrete drainage system
- slope stabilization methods required

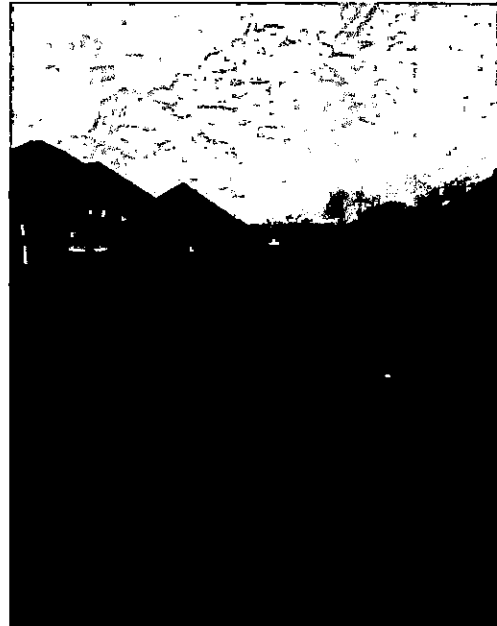

Chambers Creek Dam Reconstruction

Tom Sulak
1822 FM 66 Suite 102
Waxahachie, TX 75167
972-921-0054
tom.sulak@co.ellis.tx.us

Amount
Date Completed
Duration

\$2,200,000
10/2020
9 months

- 2 dam sites restoration
- 25,000 yards lime treated earth fill on dam reconstruction
- 3,000 yards of rip rap armored dam installed
- landscape seeding and Temp irrigation installation
- Heavy de-watering in watershed

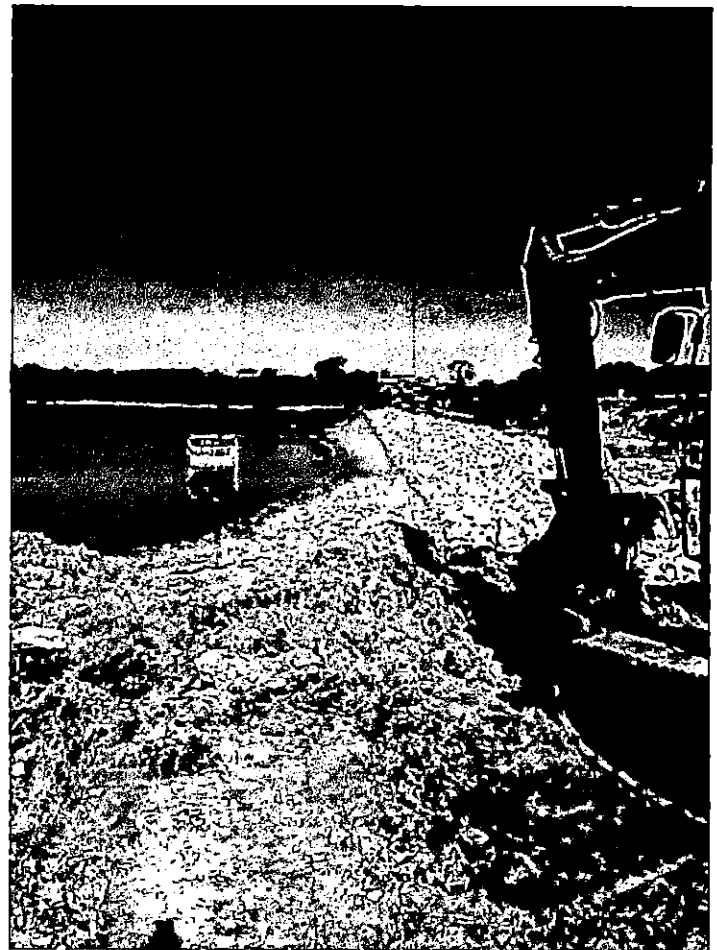
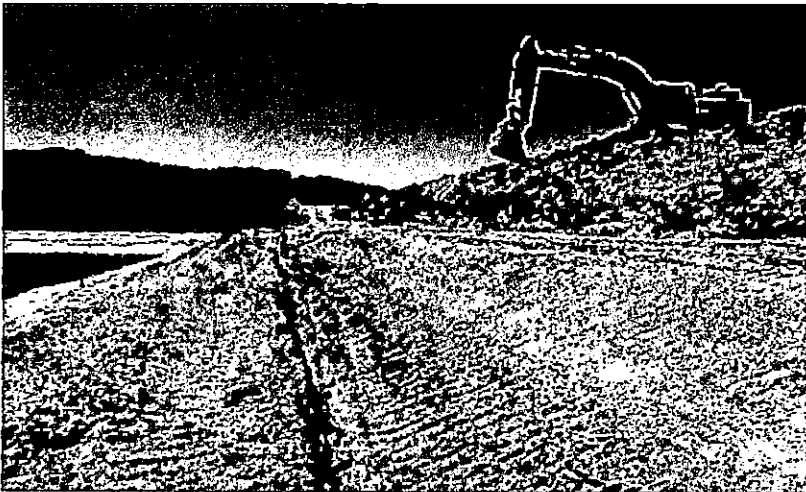

Harris Co Flood Control - Concrete Spillway & Stilling Basin

Mondel Garcia, P.E., PMP

Project Manager - Construction Division

Harris County Flood Control District - Mike Talbott Service Center

7522 Prairie Oak Drive Houston, TX 77086

Office direct - 346-286-4068

- 700' of concrete canal 7' to 13' tall
- reroute of sewer and storm crossing lines
- control of water while construction in active drainage channel

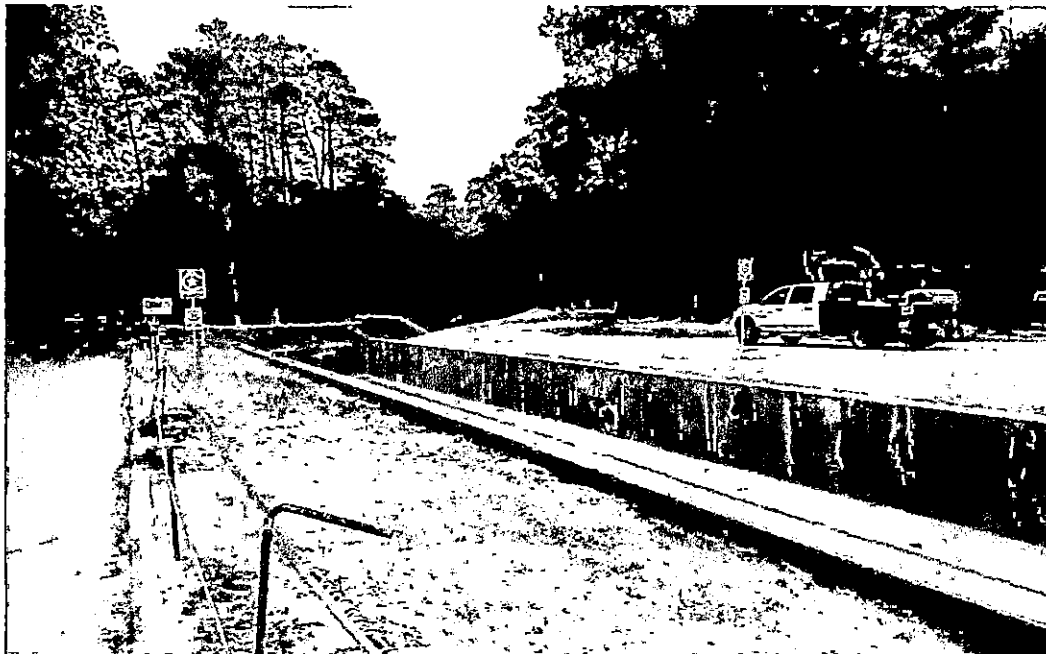
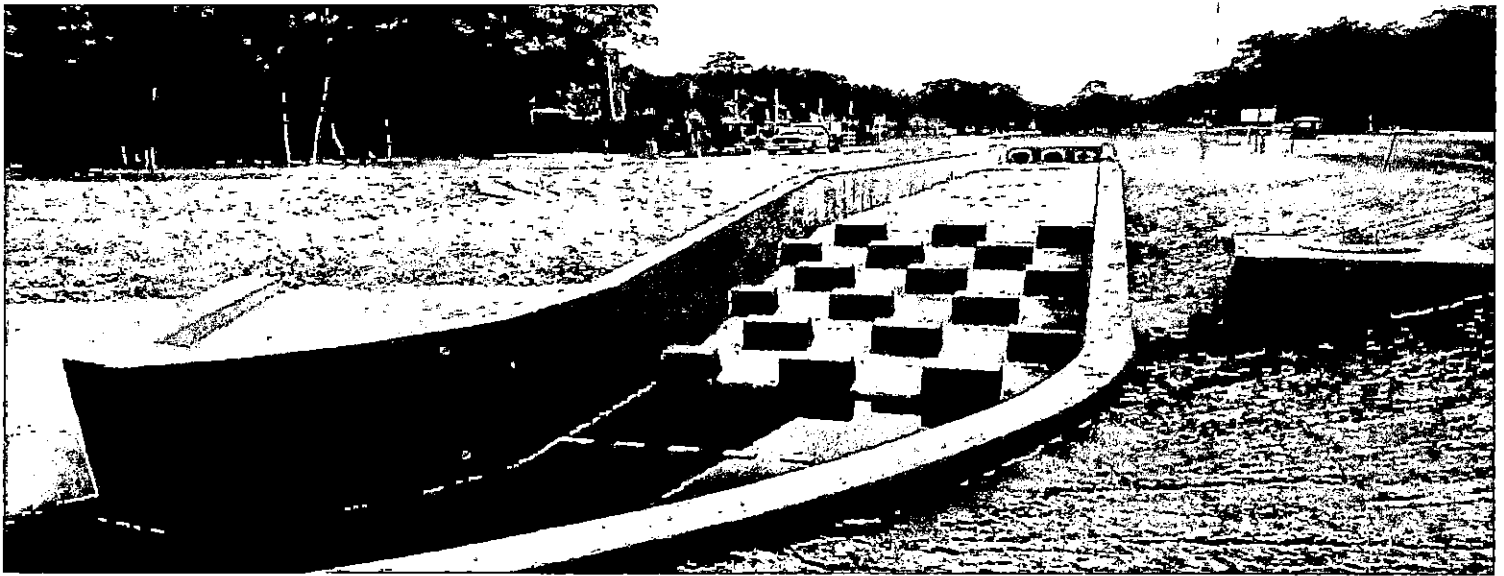

Gullo Toyota Dealerships

Rhowan Collins - CFO
Cell - 713 - 819 - 7367
750 I-46
Conroe, TX 77304

Amount 850,000
Date 5/1/2018
Duration 3 Months

Gullo Toyota - Expansion

- 1200 feet of box culvert installed in 1 week
- custom 24' x 30' junction box
- detention pond relocation



Plum Creek Watershed Site 10 Rehabilitation

Owner: PLUM CREEK CONSERVATION DISTRICT
Agency: NRCS (Natural Resources Conservation Service)
Engineer: M&E Consultants, Trent Street,
tstreet@mande-pe.com
P.O. Box 9
Heidenheimer, TX 76533

Amount	\$5,000,000
Date Completed	10/2023
Duration	24 Months

- NRCS dam rehabilitation
- installation of new concrete primary and auxiliary spillway
- 20,000 cubic yards of lime-treated earth fill dam reconstruction
- 5,000 tons of rip-rap armored shoring
- Heavy de-watering
- Heavy federal regulation and oversight

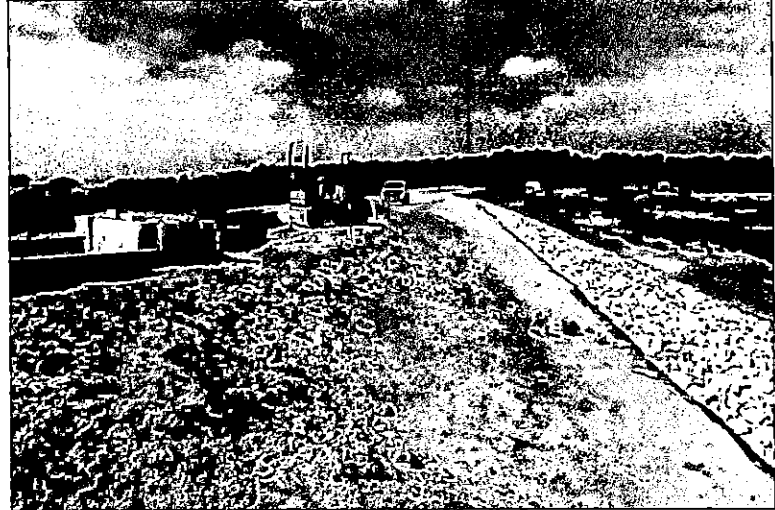

Intercontinental Waterline & Detention Pond No. 2

Owner: Eastveld Property Owner, LLC
on behalf of Intercontinental Crossing Municipal
Utility District
Engineer: Jones Engineering Solutions, LLC, James
Jones, jamesjones@jonesengineeringsolutions.com
281-507-5271

Amount	\$1,377,659
Date	10/2024
Duration	10 months

- Stormwater bores under several high pressure jet fuel lines servicing IAH George Bush Intercontinental Airport
- Heavy regulation and oversight
- Ground water



Grand Texas Big Rivers Water Park

Owner: Grand Texas
23065 TX-242, New Caney, TX
77357
832-840-7501
Engineer: Bleyl Engineering, Ken
Walker, 936-441-7833

Amount \$18,000,000
Date Completed June 2019

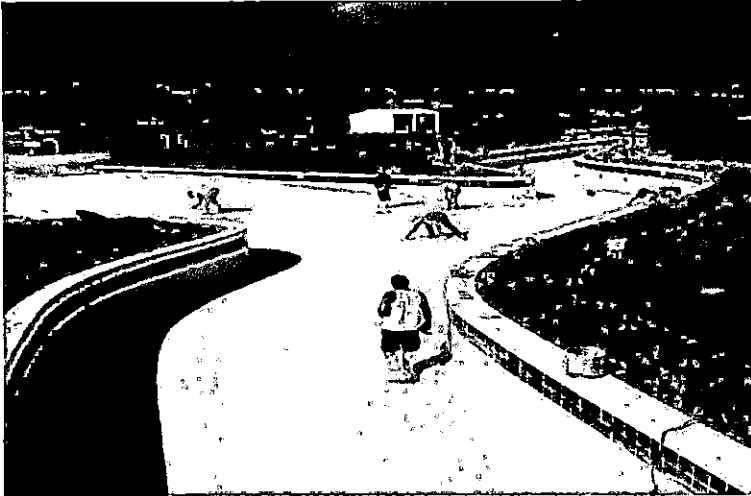

Harris Co Flood Control

Mondel Garcia P.E PMP
7522 Prairie Oak Drive
Houston, TX 77086
346-286-4068
mondel.garica@hcfcd.hctx.net

Amount 2,000,000
Date 5/1/2020
Duration 8 Months

Ben's Branch Channel Rehabilitation

- 70,000 yards of excavation and haul off
- rip rap installation
- import fill and embankment installation



East Pond Siphon

Owner: City of Shenandoah
Engineer: Bleyl Engineering, Ken Walker,
936-441-7833

Amount \$192,925
Date Completed 11/2021
Duration 3 months

- Strom water siphon/bore under high pressure 30" Natural gas pipeline
- Heavy ground water
- Heavy regulation and supervision

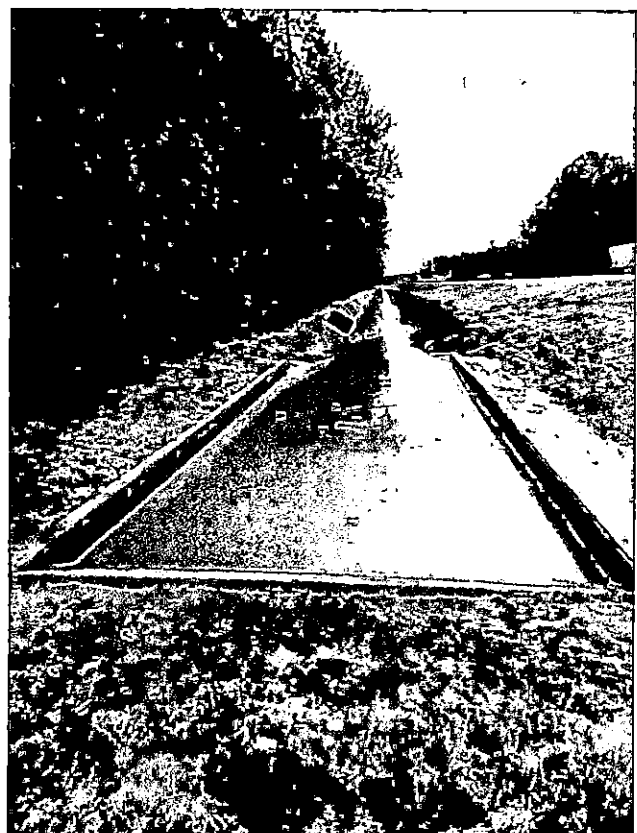

The Woodland Hills Section 18 Park

Owner: HF Holding Company, LLC,
Kelly Dietrich, 936-672-2245,
kelly.dietrich@howardhughes.com
Engineer: Landology, (281) 741-6786

Amount
Date Completed
Duration

\$1,180,589
3/2023
8 months

- City park with native trees, plants and grasses on irrigation
- Plant material under 1-year Maintenance contracts
- Specialty grade work and finishes

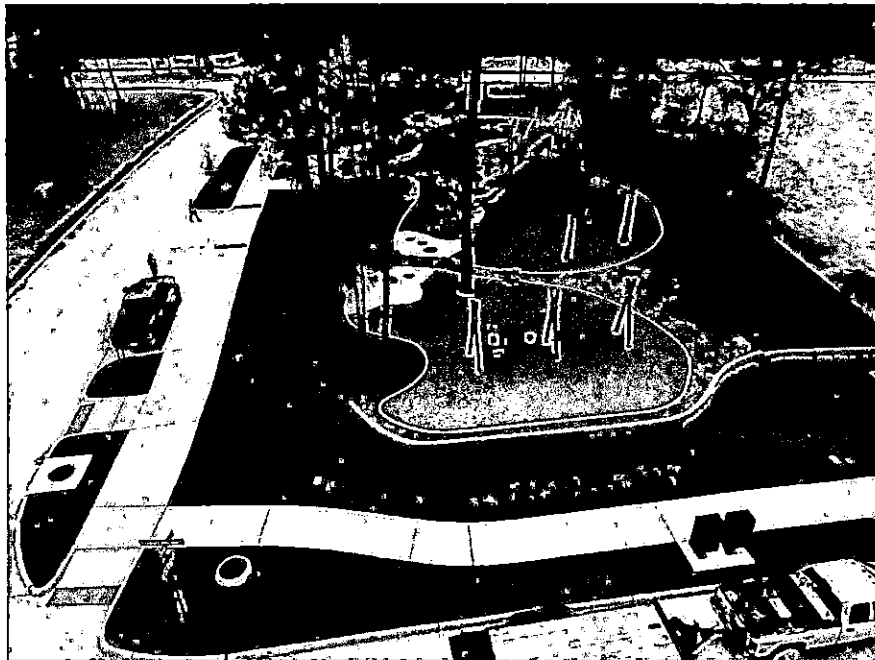

Equipment Owned

Dozers

2	John Deere with Trimble	1T0700JXLBD203028	700J	2011
3	John Deere with Trimble	1T0750KXCEE268898	750K	2015
4	John Deere with Trimble	TO850CX944625	850C	2003
5	John Deere	T0850JX127073	850J	2006
6	John Deere with Trimble	LU950JX009417	950 J	2007
7	John Deere with Trimble	LU1050J009906	1050 J	2008
8	John Deere	LU1050J010506	1050 J	2009
9	John Deere	LU1050C006024	1050C	2003
10	Liebherr with Trimble	PR716142316281	PR716 LGP	2018
11	Liebherr with Trimble	PR72475513722	PR724 LGP	2014

Scraper Tractors

1	John Deere	RW8760H003727	8760	2000
2	John Deere	1RW9460RHEE012249	9460R	2014
3	John Deere	1RW9530ECB002867	9530	2008
4	John Deere	1RW9530ECBE025582	9530	2012
5	John Deere	1RW9510RLCE003725	9510R	2012
6	John Deere	1RW9560RCCE003340	9560R	2012
7	John Deere	1RW9560RLCE006623	9560R	2013

Scraper Tractor Pans

1	Reynolds Water Pan		17 Yard	2000
2	Reynolds Water Pan		17 Yard	2000
3	Reynolds	29606	17 Yard	2000
4	Reynolds	29086	17 Yard	2000
5	Reynolds LGP		17 Yard	2008
6	Reynolds LGP		17 Yard	2008
7	John Deere		1810E	
8	John Deere	T81810E060336	1810E	2006
9	John Deere	1T81810ELD0120856	1810E	2013
10	John Deere	T81814E050154	1814E	2006
11	John Deere	T81814E060227	1814E	2006

12	John Deere	1T82112EKE120971	2112E	2014
13	John Deere	1T82112EAE0120958	2112E	2014
14	Land All Drag		Blade	2010
15	Rome Drag	GK12-102	Blade	2016

Excavators

1	Caterpillar with Trimble	CAT0329EAZCD00532	329E	2014
2	Volvo	314486	EC140E	2021
4	John Deere with Thumb	1FF135FCLEE400506	135G	2014
5	John Deere Amphibious	1FF210GXPDE521717	210G	2014
6	John Deere with Thumb	1FF245GXEGF800132	245G	2017
7	John Deere with Thumb	FF240DX605330	240D	2006
8	John Deere with Thumb	FF270DX703075	270D	2010
	John Deere	1FF300GXJDF710002	300G	2013
9	John Deere	FF330CX804677	330C	2005
10	John Deere with Thumb	FF350DX806324	350D	2008
	John Deere	1FF350GXPHF811884	350G	2017
11	John Deere with Trimble	1FF350GXKEF810490	350G	2015
12	John Deere with Q Coupler	1FF470GXHEE4710873	470G	2015
13	John Deere	1FF470GXHEE471033	470G	2015

Wheel Loaders

1	John Deere Bucket & Forks	1DW544KZTB0635207	544k	2011
2	John Deere Bucket & Forks	DW624JH594779	624J	2004
3	Case Skip Loader	JJG0302150	570	2005

Motor Graders

1	John Deere with Trimble	DW672DX608155	672D	2006
---	-------------------------	---------------	------	------

Water Trucks & Water Tower

1	LMTV Army Truck	A-T007203BCLF	LMTV	1997
---	-----------------	---------------	------	------

2	Oshkosh Fire Truck	10TDK8Z18WS064592	T-3000	1998
3	Interpipe Tower Trailer		10K Gal	2010

Heavy Haul & Dump Trucks

1	Kenworth Dump Truck	1XKDDA9X5 HS501367	T-800	1987
2	Kenworth Heavy Haul	3WKDDBOX17F196123	T-800B	2007
3	Kenworth Heavy Haul	1XKDPBTX2 8J223684	T-800B	2008
4	Peterbilt Belly Dump	1XPVD79XXBD130249	384	2008
5	Peterbilt Belly Dump	1XPVDU9X2 9D789158	384	2009
6	Peterbilt Belly Dump	1XPVD09X6AD107296	384	2010
7	Peterbilt Belly Dump	1XPHDP9X1DD187052	386	2013
8	GMC Mechanical Truck	1GDJ7J1C33F503940	C7500	2003
9	GMC Mechanical Truck	1GTHK39D87E109887	3500	2007
10	Dodge Work Truck	3D7KU28693G738547	2500	2003
11	Dodge Work Truck	1D7KS28C06J162474	2500	2006
12	Dodge Work Truck	3D7KU28C64G128788	2500	2004
13	Dodge Work Truck	3D7MX49C06G270003	3500	2006
14	Dodge Work Truck	3C7WDTCL3CG121243	3500	2012

Trailers

	Trail King 110 Heavy Haul	1TKR005840FM057298	55 Ton	2015
1	Pitts 55 Ton Heavy Haul	5JYLB553X DP130051	55 Ton	2012
2	Landoll Heavy Haul		25 Ton	1980
3	CPS Belly Dump	5MC1116279PO10092	22 CY	2009
4	Manic Belly Dump	5MC424016D3134981	22 CY	2013
5	CPS Belly Dump	5MC424019K3182553	22 CY	2019
6	CPS Belly Dump	5MC424010K3182554	22 CY	2019
7	20' Dump Trailer		10 Ton	2005
8	20' Husky Equipment Trailer	59JT1LT24GD596104	8 Ton	2016
9	20' Big Tex Equipment Trailer		8 Ton	2020
10	22' Big Tex Equipment Trailer		8 Ton	2020

Tractors With Seeding Equipment

1	Kubota Seeding Tractor		3840	2012
2	Kubota Seeding Tractor	66593	M9000	2005
3	Land Pride Seed Drill	575866	CR2572	2020
4	Land Pride Batwing Mower		LP15	2020
5	Grun SB7-T Straw Blower			
6	Lay-Mor SM400 Broom	34287	SM400	2013

Mobile Get Set & Mobile Offices

1	Kohler Mobile Gen Set		25 KW	2013
2	Kohler Mobile Gen Set	2009161	60 KW	2004

Brazos County Bridge Scour repair

Alexander Road (003)

Solid Bridge Construction LLC
Travis Hanus

832-465-7424

Project Start:

Day 1

Display Week:

1-Jan

TASK	ASSIGNED TO	PROGRESS	START	END
MOBILIZATION / Traffic Control	SBC	0%	Day 1 -	Day 7
UTILITY LOCATE / PROJECT LAYOUT/SWPPP	SBC	0%	Day 3 -	Day 10
Demo and haul off	SBC	0%	Day 5 -	Day 15
Grade / Stabilize road ways	SBC	0%	Day 12 -	Day 22
Concrete paving / curbing / cure time	SBC	0%	Day 22 -	Day 65
Rip rap and drainage	SBC	0%	Day 15 -	Day 35
Guard rails	SBC	0%	Day 30 -	Day 70
Hydroseed	SBC	0%	Day 65 -	Day 72
Punch list / final clean / De-mob	SBC	0%	Day 70 -	Day 78

Brazos County Bridge Scour repair

Alexander Road North (002)

Solid Bridge Construction LLC
Travis Hanus

832-465-7424

Project Start:

Day 1

Display Week:

1-Jan

TASK	ASSIGNED TO	PROGRESS	START	END
MOBILIZATION / Traffic Control	SBC	0%	Day 1 -	Day 7
UTILITY LOCATE / PROJECT LAYOUT/SWPPP	SBC	0%	Day 3 -	Day 10
Demo and haul off	SBC	0%	Day 5 -	Day 15
Grade / Stabilize road ways	SBC	0%	Day 12 -	Day 22
Concrete paving / curbing / cure time	SBC	0%	Day 22 -	Day 65
Rip rap and drainage	SBC	0%	Day 15 -	Day 35
Guard rails	SBC	0%	Day 30 -	Day 70
Hydroseed	SBC	0%	Day 65 -	Day 72
Punch list / final clean / De-mob	SBC	0%	Day 70 -	Day 78

Brazos County Bridge Scour repair

Collette Lane

Solid Bridge Construction LLC
Travis Hanus

832-465-7424

Project Start:

Day 1

Display Week:

1-Jan

TASK	ASSIGNED TO	PROGRESS	START	END
MOBILIZATION / Traffic Control	SBC	0%	Day 1 -	Day 7
UTILITY LOCATE / PROJECT LAYOUT/SWPPP	SBC	0%	Day 3 -	Day 10
Demo and haul off	SBC	0%	Day 5 -	Day 15
Grade / Stabilize road ways	SBC	0%	Day 12 -	Day 22
Concrete paving / curbing / cure time	SBC	0%	Day 22 -	Day 65
Rip rap and drainage	SBC	0%	Day 15 -	Day 35
Guard rails	SBC	0%	Day 30 -	Day 70
Hydroseed	SBC	0%	Day 65 -	Day 72
Punch list / final clean / De-mob	SBC	0%	Day 70 -	Day 78

Brazos County Bridge Scour repair

Harris Lane

Solid Bridge Construction LLC
Travis Hanus

832-465-7424

Project Start:

Day 1

Display Week:

1-Jan

TASK	ASSIGNED TO	PROGRESS	START	END
MOBILIZATION / Traffic Control	SBC	0%	Day 1 -	Day 7
UTILITY LOCATE / PROJECT LAYOUT/SWPPP	SBC	0%	Day 1 -	Day 10
Demo and haul off	SBC	0%	Day 5 -	Day 13
Rip rap and drainage	SBC	0%	Day 10 -	Day 17
Concrete mow strip	SBC	0%	Day 12 -	Day 20
Guard rails	SBC	0%	Day 15 -	Day 25
Hydroseed	SBC	0%	Day 22	Day 27
Punch list / final clean / De-mob	SBC	0%	Day 27	Day 30

Brazos County Bridge Scour repair

Dilly Shaw Tap Road

Solid Bridge Construction LLC
Travis Hanus

832-465-7424

Project Start:

Day 1

Display Week:

1-Jan

TASK	ASSIGNED TO	PROGRESS	START	END
MOBILIZATION / Traffic Control	SBC	0%	Day 1 -	Day 7
UTILITY LOCATE / PROJECT LAYOUT/SWPPP	SBC	0%	Day 3 -	Day 10
Demo and haul off	SBC	0%	Day 5 -	Day 15
Grade / Stabilize road ways	SBC	0%	Day 12 -	Day 22
Concrete paving / curbing / cure time	SBC	0%	Day 22 -	Day 65
Rip rap and drainage	SBC	0%	Day 15 -	Day 35
Guard rails	SBC	0%	Day 30 -	Day 70
Hydroseed	SBC	0%	Day 65 -	Day 72
Punch list / final clean / De-mob	SBC	0%	Day 70 -	Day 78

Brazos County Bridge Scour repair

Kurten Cemetery Road

Solid Bridge Construction LLC
Travis Hanus

832-465-7424

Project Start:

Display Week:

TASK	ASSIGNED TO	PROGRESS	START	END
MOBILIZATION / Traffic Control	SBC	0%	Day 1 -	Day 7
UTILITY LOCATE / PROJECT LAYOUT/SWPPP	SBC	0%	Day 3 -	Day 10
Demo and haul off	SBC	0%	Day 5 -	Day 15
Grade / Stabilize road ways	SBC	0%	Day 12 -	Day 22
Concrete paving / curbing / cure time	SBC	0%	Day 22 -	Day 65
Rip rap and drainage	SBC	0%	Day 15 -	Day 35
Guard rails	SBC	0%	Day 30 -	Day 70
Hydroseed	SBC	0%	Day 65 -	Day 72
Punch list / final clean / De-mob	SBC	0%	Day 70 -	Day 78

Brazos County Bridge Scour repair

Fickey Road (001)

Solid Bridge Construction LLC
 Travis Hanus

832-465-7424

Project Start:

Day 1

Display Week:

1-Jan

TASK	ASSIGNED TO	PROGRESS	START	END
MOBILIZATION / Traffic Control	SBC	0%	Day 1 -	Day 7
UTILITY LOCATE / PROJECT LAYOUT/SWPPP	SBC	0%	Day 3 -	Day 10
Demo and haul off	SBC	0%	Day 5 -	Day 15
Grade / Stabilize road ways	SBC	0%	Day 12 -	Day 22
Concrete paving / curbing / cure time	SBC	0%	Day 22 -	Day 65
Rip rap and drainage	SBC	0%	Day 15 -	Day 35
Guard rails	SBC	0%	Day 30 -	Day 70
Hydroseed	SBC	0%	Day 65 -	Day 72
Punch list / final clean / De-mob	SBC	0%	Day 70 -	Day 78

Brazos County Bridge Scour repair

Fickey Road (002)

Solid Bridge Construction LLC
Travis Hanus

832-465-7424

Project Start:

Day 1

Display Week:

1-Jan

TASK	ASSIGNED TO	PROGRESS	START	END
MOBILIZATION / Traffic Control	SBC	0%	Day 1 -	Day 7
UTILITY LOCATE / PROJECT LAYOUT/SWPPP	SBC	0%	Day 9 -	Day 10
Demo and haul off	SBC	0%	Day 5 -	Day 15
Grade / Stabilize road ways	SBC	0%	Day 12 -	Day 22
Concrete paving / curbing / cure time	SBC	0%	Day 22 -	Day 65
Rip rap and drainage	SBC	0%	Day 15 -	Day 35
Guard rails	SBC	0%	Day 30 -	Day 70
Hydroseed	SBC	0%	Day 65 -	Day 72
Punch list / final clean / De-mob	SBC	0%	Day 70 -	Day 78

Brazos County Bridge Scour repair

Deep Well Road

Solid Bridge Construction LLC
Travis Hanus

832-465-7424

Project Start:

Day 1

Display Week:

1-Jan

TASK	ASSIGNED TO	PROGRESS	START	END
MOBILIZATION / Traffic Control	SBC	0%	Day 1 -	Day 7
UTILITY LOCATE / PROJECT LAYOUT/SWPPP	SBC	0%	Day 1 -	Day 10
Demo and haul off	SBC	0%	Day 5 -	Day 13
Rip rap and drainage	SBC	0%	Day 10 -	Day 17
Concrete mow strip	SBC	0%	Day 12 -	Day 20
Guard rails	SBC	0%	Day 15 -	Day 25
Hydroseed	SBC	0%	Day 22	Day 27
Punch list / final clean / De-mob	SBC	0%	Day 27	Day 30



**BRAZOS COUNTY
BRYAN, TEXAS**

DEPARTMENT:

NUMBER:

DATE OF COURT MEETING: 6/23/2026

ITEM: Approve of the Interlocal Agreement of Surplus Property Transfer between Brazos County and Burleson County.

TO: Commissioners Court

DATE: 06/09/2026

FISCAL IMPACT: False

BUDGETED: False

DOLLAR AMOUNT: \$0.00

ATTACHMENTS:

File Name

Description

Type

[IA for Surplus Propert Transfer.pdf](#)

ILA Surplus Property Transfer

Cover Memo

[E-mail backup RE Interlocal Agreement.pdf](#)

email backup

Cover Memo

STATE OF TEXAS §

COUNTY OF BRAZOS §

**INTERLOCAL AGREEMENT
SURPLUS PROPERTY TRANSFER**

This Interlocal Agreement (“Agreement”) is made and entered into on this the 8th day of JUNE, 2026, by and between Brazos County, Texas (“County”) a political subdivision of the State of Texas, and the Burleson County, Texas (“Burleson County”), political subdivision of the State of Texas.

WHEREAS, the parties to this Agreement are both political subdivisions of the State of Texas, empowered by Texas Government Code Chapter 263.152(a)(1), to enter into an interlocal agreement to sell surplus property; and

WHEREAS, the County is the owner of certain surplus property, specifically 286 road signs and miscellaneous signs and

WHEREAS, the Brazos County Commissioner’s Court has determined that it is in the best interests of the community to transfer ownership of the signs to the Burleson County so that it can be used more effectively for the benefit of all; and

NOW, THEREFORE, IT IS AGREED AS FOLLOWS:

1. The County Commissioner’s Court has authorized the County Judge to execute this Agreement to convey ownership and possession of the signs to Burleson County for the sum of ONE HUNDRED AND 00/100THS DOLLARS (\$100.00). Possession will be transferred at a time and place mutually agreeable to the parties. Payment shall be made by Burleson County within thirty (30) days of commencement of this Agreement.
2. Burleson County has authorized the Burleson County Judge to execute this Agreement to accept ownership of the signs and covenants and agrees that the signs will continue to be used for a public purpose.
3. This Agreement shall commence when executed by all parties, on the date the last party signs, and it ends when the transfer of title and possession is complete.

4. If any provision of this Agreement is held by a court of competent jurisdiction to be illegal, invalid, or unenforceable under present or future laws effective while this Agreement is in effect, such provision shall be automatically deleted from this Agreement and the legality, validity, and enforceability of the remaining provisions of this Agreement shall not be affected thereby, and in lieu of such deleted provision, there shall be added as part of this Agreement a provision that is legal, valid and enforceable and that is as similar as possible in terms and substance as possible to the deleted provision.
5. This Agreement constitutes the sole and only Agreement of the Parties hereto respecting the subject matter covered by this Agreement, and supersedes any prior understandings or written or oral agreements between the parties. No amendment, modification or alteration of the terms hereof shall be binding unless the same shall be in writing and dated subsequent to the date hereof and duly executed by the parties hereto.
6. This Agreement shall be construed under and in accordance with the laws of the State of Texas and the obligations of the parties created hereunder are performable by the parties in the Burleson County, Texas. Venue for any litigation arising under this Agreement shall be in a court of appropriate jurisdiction in Brazos County, Texas.
7. The determinations recited and declared in the preambles to this Agreement are hereby incorporated herein as part of this Agreement.

Executed to be effective as of the date above written.

BURLESON COUNTY, TEXAS



 Keith Schroeder, County Judge

BRAZOS COUNTY, TEXAS

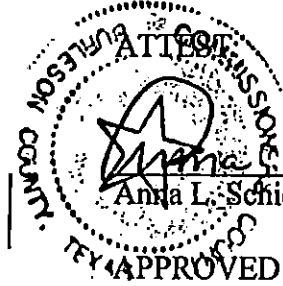
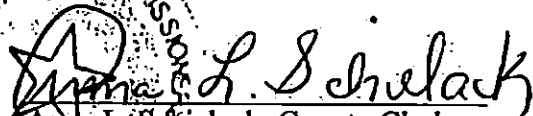

 Duane Peters, County Judge

ATTEST:

 ATTEST:

 Anna L. Schielack, County Clerk

 Karen McQueen, Brazos County Clerk

APPROVED AS TO FORM

 William Ballard, General Counsel

 Brazos County General Counsel / ASST.

From: [Burleson County Judge](#)
To: [Marsha D. Anderson](#)
Subject: RE: Interlocal Agreement
Date: Monday, June 8, 2026 11:48:16 AM
Attachments: [image001.png](#)
[IA for Surplus Propert Transfer.pdf](#)

Brazos County Disclaimer

***** This is an email from an EXTERNAL source. DO NOT click links or open attachments unless you recognize the sender and have verified that the content is safe. Never enter USERNAME, PASSWORD or sensitive information on pages linked from this email.*****

Is this better ☺

From: Marsha D. Anderson [mailto:MAAnderson@brazoscountytexas.gov]
Sent: Monday, June 8, 2026 11:09 AM
To: Burleson County Judge <co_judge@burlesoncounty.org>
Cc: William C. Wendt <cwendt@brazoscountytexas.gov>
Subject: RE: Interlocal Agreement

Hello, Karen,

The attached is not showing. Would you please resubmit the document.

Marsha Anderson

From: Burleson County Judge <co_judge@burlesoncounty.org>
Sent: Monday, June 8, 2026 10:55 AM
To: Marsha D. Anderson <MAAnderson@brazoscountytexas.gov>
Cc: William C. Wendt <cwendt@brazoscountytexas.gov>
Subject: Interlocal Agreement

Brazos County Disclaimer

***** This is an email from an EXTERNAL source. DO NOT click links or open attachments unless you recognize the sender and have verified that the content is safe. Never enter USERNAME, PASSWORD or sensitive information on pages linked from this email.*****

To All: This agreement was signed today in Commissioners Court. It now needs to be signed by Brazos County. Once signed, can you send a copy back to us. Thank you ☺

Karen Bolt
100 West Buck, Suite 306
Caldwell, Texas 77836
(979) 567-2333



Burlison County

Marsha D. Anderson

From: Marsha D. Anderson
Sent: Monday, June 8, 2026 12:31 PM
To: William C. Wendt; Prarthana P. Banerji
Cc: Edward C. Bull; Andrew Wipke
Subject: FW: Interlocal Agreement
Attachments: IA for Surplus Propert Transfer.pdf

Hello, Charles and Prarthana,

I would very much appreciate your review over the attached document received form Burleson County. Please let me know if this should be an agenda item so that it may be added to the upcoming agenda of June 23. If it is not an agenda item , I will begin the process to obtain the necessary signatures. Thanks for the review.

Marsha Anderson

From: Burleson County Judge <co_judge@burlesoncounty.org>
Sent: Monday, June 8, 2026 11:48 AM
To: Marsha D. Anderson <MAnderson@brazoscountytexas.gov>
Subject: RE: Interlocal Agreement

Brazos County Disclaimer

***** This is an email from an EXTERNAL source. DO NOT click links or open attachments unless you recognize the sender and have verified that the content is safe. Never enter USERNAME, PASSWORD or sensitive information on pages linked from this email.*****

Is this better ☺

From: Marsha D. Anderson [<mailto:MAnderson@brazoscountytexas.gov>]
Sent: Monday, June 8, 2026 11:09 AM
To: Burleson County Judge <co_judge@burlesoncounty.org>
Cc: William C. Wendt <cwendt@brazoscountytexas.gov>
Subject: RE: Interlocal Agreement

Hello, Karen,

The attached is not showing. Would you please resubmit the document.

Marsha Anderson

From: Burleson County Judge <co_judge@burlesoncounty.org>
Sent: Monday, June 8, 2026 10:55 AM
To: Marsha D. Anderson <MAnderson@brazoscountytexas.gov>
Cc: William C. Wendt <cwendt@brazoscountytexas.gov>
Subject: Interlocal Agreement

Brazos County Disclaimer

***** This is an email from an EXTERNAL source. DO NOT click links or open attachments unless you recognize the sender and have verified that the content is safe. Never enter USERNAME, PASSWORD or sensitive information on pages linked from this email.*****

To All: This agreement was signed today in Commissioners Court. It now needs to be signed by Brazos County. Once signed, can you send a copy back to us. Thank you ☺

Karen Bolt

100 West Buck, Suite 306
Caldwell, Texas 77836
(979) 567-2333



Burleson County



**BRAZOS COUNTY
BRYAN, TEXAS**

DEPARTMENT: Purchasing NUMBER:

DATE OF COURT MEETING: 6/23/2026

ITEM: Approval to sell a total of 286 road and miscellaneous signs to Burleson County for a total of \$100.00 pursuant to Local Government Code §263.152. These items are no longer needed for county use.

TO: Commissioners Court

FROM: Celina Nava

DATE: 06/15/2026

FISCAL IMPACT: False

BUDGETED: False

DOLLAR AMOUNT: \$0.00

NOTES/EXCEPTIONS: Road and Bridge is no longer needing a total of 286 road and miscellaneous signs they are located in the Brazos County Road and Bridge. Burleson County has agreed to purchase road signs in the amount \$100.00 as is.

ATTACHMENTS:

<u>File Name</u>	<u>Description</u>	<u>Type</u>
20260615093047557.pdf	ILA with Burleson County	Backup Material
Burleson County - Surplus Property To Be Sold.pdf	Sign List	Backup Material

STATE OF TEXAS §

COUNTY OF BRAZOS §

**INTERLOCAL AGREEMENT
SURPLUS PROPERTY TRANSFER**

This Interlocal Agreement ("Agreement") is made and entered into on this the 8th day of JUNE, 2026, by and between Brazos County, Texas ("County") a political subdivision of the State of Texas, and the Burleson County, Texas ("Burleson County"), political subdivision of the State of Texas.

WHEREAS, the parties to this Agreement are both political subdivisions of the State of Texas, empowered by Texas Government Code Chapter 263.152(a)(1), to enter into an interlocal agreement to sell surplus property; and

WHEREAS, the County is the owner of certain surplus property, specifically 286 road signs and miscellaneous signs and

WHEREAS, the Brazos County Commissioner's Court has determined that it is in the best interests of the community to transfer ownership of the signs to the Burleson County so that it can be used more effectively for the benefit of all; and

NOW, THEREFORE, IT IS AGREED AS FOLLOWS:

1. The County Commissioner's Court has authorized the County Judge to execute this Agreement to convey ownership and possession of the signs to Burleson County for the sum of ONE HUNDRED AND 00/100THS DOLLARS (\$100.00). Possession will be transferred at a time and place mutually agreeable to the parties. Payment shall be made by Burleson County within thirty (30) days of commencement of this Agreement.
2. Burleson County has authorized the Burleson County Judge to execute this Agreement to accept ownership of the signs and covenants and agrees that the signs will continue to be used for a public purpose.
3. This Agreement shall commence when executed by all parties, on the date the last party signs, and it ends when the transfer of title and possession is complete.

4. If any provision of this Agreement is held by a court of competent jurisdiction to be illegal, invalid, or unenforceable under present or future laws effective while this Agreement is in effect, such provision shall be automatically deleted from this Agreement and the legality, validity, and enforceability of the remaining provisions of this Agreement shall not be affected thereby, and in lieu of such deleted provision, there shall be added as part of this Agreement a provision that is legal, valid and enforceable and that is as similar as possible in terms and substance as possible to the deleted provision.
5. This Agreement constitutes the sole and only Agreement of the Parties hereto respecting the subject matter covered by this Agreement, and supersedes any prior understandings or written or oral agreements between the parties. No amendment, modification or alteration of the terms hereof shall be binding unless the same shall be in writing and dated subsequent to the date hereof and duly executed by the parties hereto.
6. This Agreement shall be construed under and in accordance with the laws of the State of Texas and the obligations of the parties created hereunder are performable by the parties in the Burleson County, Texas. Venue for any litigation arising under this Agreement shall be in a court of appropriate jurisdiction in Brazos County, Texas.
7. The determinations recited and declared in the preambles to this Agreement are hereby incorporated herein as part of this Agreement.

Executed to be effective as of the date above written.



BURLESON COUNTY, TEXAS

 Keith Schroeder, County Judge

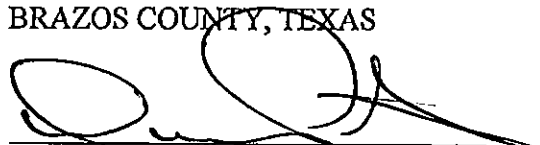
BRAZOS COUNTY, TEXAS

 Duane Peters, County Judge

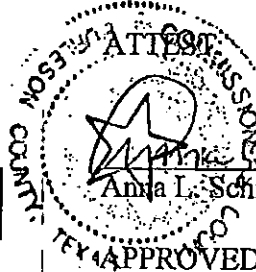
ATTEST:

 ATTEST:

 Anna L. Schielack, County Clerk

 Karen McQueen, Brazos County Clerk

APPROVED AS TO FORM

APPROVED AS TO FORM

 William Ballard, General Counsel

 Brazos County General Counsel, *Assats*

SURPLUS PROPERTY TO BE SOLD TO BURLESON COUNTY

Approval to sell the followings signs to Burleson County for a total of \$100.00 pursuant to Local Government Code 263.152. These signs are no longer in use in Brazos County.

Size	Aluminum Signs	Quantity	Pallet #1
30x30	Slow handicapped child area	10	
30x30	Slow autistic child area	4	
30x30	Autistic child area	2	
30x30	Children play	4	
30x30	Bridge Out	20	
30x30	Fasten Seat Belts State Law	3	
30x30	No Commercial Truck Parking Overnight	4	
30x30	Pedestrian	10	
30x30	Deer Crossing	2	
30x30	Water Over Road Fold-Up	8	
36x36	No Parking Symbol	6	
36x36	Plant Entrance Ahead	1	
36x36	Truck Crossing	2	
36x36	Two – Way Traffic	8	

Size	Aluminum Signs	Quantity	Pallet #2
24x60	End Construction	10	

Size	Aluminum Signs	Quantity	Pallet #3
36x36	Speed Limit Reduced 45	1	
24x36	Do Not Stop On Tracks	4	
34x30	Local Deliveries Only	1	
24x30	Keep Right	1	
24x30	Do Not Block Intersection	10	
24x30	Do Not Pass	23	
30x30	Stop Sign	10	
24x24	Deaf Child	1	
18x24	Truck Route	4	
18x24	Unless Otherwise Posted	3	
18x18	Yellow Diamond Plate	11	
18x18	No Parking Symbol	7	
12x24	Cross Traffic Does Not Stop	28	
8x36	No Outlet	6	
6x12	Between Signs	29	

Size	Aluminum Signs	Quantity	Pallet #4
36x36	Stop Ahead	19	
36x36	No Center Stripe	4	
30x30	Caution Flood Prone Area Ahead	15	
24x36	Weight Limit Gross 30,000 LBS	15	



**BRAZOS COUNTY
BRYAN, TEXAS**

DEPARTMENT: Budget Office NUMBER:

DATE OF COURT MEETING: 6/23/2026

ITEM: Approval of the Community Supervision and Corrections Department Interlocal Cooperation Contract for Fiscal Year 2027.

TO: Commissioners Court

FROM: Nina Payne

DATE: 06/04/2026

FISCAL IMPACT: True

BUDGETED: False

DOLLAR AMOUNT: \$280,000.00

SOURCE OF FUNDS: General Fund - County Recovery Court (Division 22700100)

REQUIREMENTS: Due to reduced funding from the State of Texas for Specialty Courts, the County agrees to supplement the County Recovery Court budget to fund Community Supervision Officers (CSO) and a Senior Substance Abuse Counselor. The additional funding is supported by benefits of continuing the County Recovery Court which, include but are not limited, enhanced public safety, reduced recidivism rates, reduced incarcerations, and increased productivity of County Recovery Court participants.

The CSCD will provide two supervision officers and one counselor to the County Recovery Court. The staff will be assigned to this program shall be approved by the presiding judge of the County Recovery Court.

ACTION REQUESTED OR ALTERNATIVES: Review and approve.

ATTACHMENTS:

<u>File Name</u>	<u>Description</u>	<u>Type</u>
Approved FY 26 Interlocal Cooperation Contract - CSCD and Brazos County Specialty Court 8.12.25.pdf	FY 2026 ILA Contract approved 812/2025	Backup Material
Agenda Revised 2027 ILA - CSCD and Brazos County Recovery Court (003) (002) (1).pdf	FY 2027 ILA Contract	Backup Material



**BRAZOS COUNTY
BRYAN, TEXAS**

DEPARTMENT	Budget Office	NUMBER
DATE OF COURT MEETING	6/23/2026	
ITEM	Approval of the Community Supervision and Corrections Department Interlocal Cooperation Contract for Fiscal Year 2027	
TO	Commissioners Court	
FROM	Nina Payne	
DATE	06/04/2026	
FISCAL IMPACT	True	
BUDGETED	False	
DOLLAR AMOUNT	\$280 000 00	
SOURCE OF FUNDS	General Fund - County Recovery Court (Division 22700100)	
REQUIREMENTS	<p>Due to reduced funding from the State of Texas for Specialty Courts the County agrees to supplement the County Recovery Court budget to fund Community Supervision Officers (CSO) and a Senior Substance Abuse Counselor. The additional funding is supported by benefits of continuing the County Recovery Court which include but are not limited to enhanced public safety, reduced recidivism rates, reduced incarcerations, and increased productivity of County Recovery Court participants.</p> <p>The CSCD will provide two supervision officers and one counselor to the County Recovery Court. The staff assigned to this program shall be approved by the presiding judge of the County Recovery Court.</p>	
ACTION REQUESTED OR ALTERNATIVES	Review and approve	

ATTACHMENTS

<u>File Name</u>	<u>Description</u>	<u>Type</u>
Approved_FY_26_Interlocal_Cooperation_Contract_CSCD_and_Brazos_County_Specialty_Court_8 12 25 pdf	FY 2026 ILA Contract approved 8/12/2025	Backup Material
Agenda_Revised_2027_ILA_CSCD_and_Brazos_County_Recovery_Court_(003)_(002) pdf	FY 2027 ILA Contract	Backup Material

COUNTY OF BRAZOS §
STATE OF TEXAS §

**INTERLOCAL COOPERATION AGREEMENT
BETWEEN COUNTY OF BRAZOS, TEXAS AND BRAZOS COUNTY COMMUNITY
SUPERVISION AND CORRECTIONS DEPARTMENT IN RELATION TO THE
RECOVERY COURT PROGRAMS**

This Agreement is made effective as of this 1 day of October, 2026, by and between **BRAZOS COUNTY, TEXAS** hereinafter referred to as “County”, and the **BRAZOS COUNTY COMMUNITY SUPERVISION AND CORRECTIONS DEPARTMENT** hereinafter referred to as “CSCD” pursuant to the provisions of the Texas Interlocal Cooperation Act, as follows

WHEREAS, Texas Government Code, Chapter 791, authorizes local governments of the state to enter into contracts for governmental function and services to increase their efficiency and effectiveness, and

WHEREAS, the County is a local government as defined in the Texas Government Code, Section 791 003(4), and possesses the authority to enter into this Agreement, and have entered into this Agreement by the action of its government body in the appropriate manner prescribed by law, and

WHEREAS, the County is entering into this Agreement pursuant to its authority under Texas Government Code, Chapter 76 007 for the limited purpose of assisting with the financing of programs operated by CSCD, and

WHEREAS, the County therefore desires to expend funds to assist CSCD with the expenses of maintaining its Recovery Court in Brazos County, and

WHEREAS, the County and CSCD desire to clarify the terms and conditions of the uses of such funds provided by Brazos County,

NOW THEREFORE, for and in good and valuable consideration the receipt and sufficiency of which are hereby acknowledged, the County and CSCD hereby agree as follows,

1 Statement of Services to be Performed

CSCD will perform the following services

- A The CSCD will provide two supervision officers and one Senior Substance Abuse Counselor to the Brazos County Recovery Court (Court ID 58) The CSOs and Senior Substance Abuse Counselor assigned to this program shall be approved by the presiding judge of the Recovery Court (Court ID 58) program
- B CSCD shall be solely responsible for the employment and management

of the CSOs and Senior Substance Abuse Counselor The County will have no input into CSCD decisions with regard to management or work of CSCD personnel, although **the work of the CSCD personnel assigned shall be primarily Recovery Court (Court ID 58) duties**

- C The assigned CSOs and Senior Substance Abuse Counselor shall remain the employees of the CSCD and shall be eligible for all state benefits, incentives, merit increases, and promotions afforded to other CSCD officers and employees
- D The assigned CSO's and Senior Substance Abuse Counselor's salary shall be paid through the CSCD department budget and the CSOs will have caseloads that consist solely of (100%) of Recovery Court participants and/or Recovery Court graduates

2 Contract amount and basis for calculating costs

The amount of this funding contract will not exceed **Two Hundred Eighty Thousand Dollars and No Cents (\$280,000)** At the time of this contract the estimated amount of funding is **Two Hundred Seventy Thousand Six Hundred Forty-Two Dollars and Sixty-Eight Cents (\$270,642.68)** This amount is intended to cover the salary and benefit costs of the two CSCD Officers and Senior Substance Abuse Counselor assigned to the Brazos County Recovery Court The Contract funds will be paid through the BCRC budget

3 Term of Agreement

This Contract is effective on October 1, 2026 The Contract will terminate on September 30, 2027, or upon written request of either party with 30 calendar days' written notice whichever occurs earlier

4 Payment for Services

CSCD will submit quarterly invoices to the County County will remit payment to CSCD approximately 30 calendar days after County's receipt of the invoice County will only make quarterly payments for amounts actually paid to the CSCD employees assigned to the Recovery Court

5 Audit

CSCD agrees to give County and its authorized representatives' access to, and the right, to examine expenditures in relation to the Recovery Court

6 Conflict of Law

Nothing in this Agreement shall be construed so as to require the commission of any act contrary to law and whenever there is any conflict between any provision of this Agreement and any present or future law, ordinance, or administrative, executive or judicial regulation, order or decree, or amendment thereof, contrary to which the parties have no legal right to contract, the latter shall prevail, but in such event the

affected provision(s) of this Agreement shall be modified only to the extent necessary to bring them within the legal requirements and only during the time such conflict exists

7 No Waiver

No waiver by any party hereto of any breach of any provision of the Agreement shall be deemed to be a waiver of any preceding or succeeding breach of the same or any other provision hereof

8 Entire Agreement

This Agreement contains the entire contract between the parties hereto and each party acknowledges that neither has made (either directly or through any agent or representative) any representation or agreement in connections with this Agreement not specifically set forth herein This Agreement may be modified or amended only by agreement in writing executive by CSCD and County

9 Venue and Choice of Law

This Agreement shall be construed under and in accordance with the laws of the State of Texas, and all obligations of the parties created hereunder are performable in Brazos County, Texas The parties hereby consent to personal jurisdiction in Brazos County, Texas

10 Notice

Except as may be otherwise specifically provided in this Agreement, all notices, demands, requests or communication required or permitted hereunder shall be in writing and shall either be (i) personally delivered against a written receipt, or (ii) sent by registered or certified mail, return receipt requested, postage prepaid and addressed to the parties at the addresses set forth below, or at such other addresses as may have been theretofore specified by written notice delivered in accordance herewith

Brazos County

Duane Peters, County Judge
200 S Texas Avenue, Suite 332, Bryan, TX 77803
Email dpeters@brazoscountytexas.gov
Phone 979-361-4101

Brazos County Community Supervision and Corrections Department

Jennifer Goerig, CSCD
Director 321 E 26th Street, Suite 300
Bryan, Texas 77803
Email jgoerig@brazoscountytexas.gov
Phone 979-361-4429

Each notice which shall be delivered or mailed in the manner described above shall be deemed sufficiently given for all purposes at such time as it is personally delivered to the addressee or, if mailed, at such time as it is deposited in the United States mail

11 Successors

This Agreement shall be binding upon and inure to the benefit of the parties hereto and their respective successors, heirs, executors, administrators, and legal administrators, where permitted by this Agreement

12 Assignment

This Agreement shall not be assignable

13 Headings

The headings and captions contained in this Agreement are solely for the convenience of reference and shall not be deemed to affect the meaning or interpretation of any provision of paragraph hereof

14 Non-Discrimination

This Agreement and all related activities shall be conducted in a manner that does not discriminate against any person on a basis prohibited by applicable law or County and CSCD policy, including without limitation race, color, national origin, religion, sex, age, veteran status, or disability

15 Authority to Executive

The execution and performance of this Agreement by CSCD and County have been duly authorized by all necessary laws, resolutions corporate action, and this Agreement constitutes the valid and enforceable obligations of CSCD and County in accordance with its terms

16 Governmental Purpose

Each party hereto enters into this agreement for the purpose of providing for governmental services or functions and will pay for such services out of current revenues available to the paying party as herein provided

17 Indemnification

CSCD shall indemnify and hold County harmless from any and all claims, actions, liability, and expenses (including costs of judgements, settlements, court costs, and attorneys' fees, regardless of outcome of such claim or action) caused by, resulting from, or alleging negligent or intentional acts or omissions or any failure to perform any obligation undertaken or any covenant in this Agreement. Upon written notice from the County, the CSCD will resist and defend at its own expense, and by counsel reasonably satisfactory to County, any such claim or action.

18 Commitment of Current Revenues Only

In the event that during any term, the Brazos County Commissioners Court does not appropriate sufficient funds to meet the obligations of such party under this Agreement, then any party may terminate this Agreement upon ninety (90) days written notice to the other party. Each of the parties hereto agrees, however, to use its best efforts to secure funds necessary for the continued performances of this Agreement. The parties intend this provision to be a continuing right to terminate this Agreement at the expiration of each budget period of each party.

(Signature Page to Follow)

IN WITNESS THEREOF, the parties hereto have caused this Agreement to be executed by their authorized officers thereon the day and the year first written above

BRAZOS COUNTY



Duane Peters
County Judge

CSCD



Jennifer Goerig
CSCD Director

6/23/26
Date

6/4/26
Date

ATTEST



Karen McQueen
County Clerk

6/23/26
Date

INTERLOCAL COOPERATION CONTRACT

1.

CONTRACTING PARTIES and AUTHORITY

The Brazos County Community Supervision and Corrections Department (CSCD) and Brazos County (County) enter into this Interlocal Cooperation Contract (Contract) under the authority of the Texas Government Code Chapter 791 (the Interlocal Cooperation Act).

County certifies that it has the authority to contract for the services agreed upon as granted in Texas Local Government Code Chapter 262 (County Purchasing Act).

CSCD certifies that it has authority to perform the services contracted for by authority granted in Texas Government Code Chapter 76.008.

2. **BACKGROUND and PURPOSE**

Due to reduced funding from the State of Texas for Specialty Courts, the County agrees to supplement the Specialty Court budget to fund Community Supervision Officers (CSO). The additional funding is supported by the benefits of continuing the Specialty Court Program which include, but are not limited to, enhanced public safety, reduced recidivism rates, reduced incarcerations, and increased productivity of Specialty Court participants.

CSCD provides supervision officers to the Brazos County Specialty Court.

3. **STATEMENT OF SERVICES TO BE PERFORMED**

CSCD will perform the following services.

- A. The CSCD will provide two supervision officers to the Brazos County Specialty Court (BCSC). The CSOs assigned to this program shall be approved by the presiding judge of the Specialty Court program.
- B. CSCD shall be solely responsible for the employment and management of the CSOs. The County will have no input into CSCD decisions with regard to management or work of CSCD personnel, although the work of the CSCD personnel assigned shall be primarily Specialty Court Program duties.
- C. The assigned CSOs shall remain the employee of the CSCD and shall be eligible for all state benefits, incentives, merit increases, and promotions afforded to other CSCD officers and employees.
- D. The assigned CSO's salary shall be paid through the BCSC department budget and the CSOs will have caseloads that consist solely (100%) of Specialty Court participants and/or Specialty Court graduates.

4. CONTRACT AMOUNT and BASIS FOR CALCULATING COSTS

The amount of this funding contract will not exceed **Two Hundred and Five Thousand Dollars and No Cents (\$205,000)**. At the time of this contract the estimated amount of funding is **Two Hundred and One Thousand Eight Hundred and Seven Dollars and No Cents (\$201,807)**. This amount is intended to cover the salary and benefit costs of the two CSCD Officers assigned to the Brazos County Specialty Court. The Contract funds will be paid through the BCSC budget.

5. PAYMENT FOR SERVICES

CSCD will submit quarterly invoices to the County. County will remit payment to CSCD approximately 30 calendar days after County's receipt of the invoice. County will only make quarterly payments for amounts actually paid to the CSCD employees assigned to the Specialty Court.

6. TERM OF CONTRACT and AMENDMENTS

This Contract is effective on October 1, 2025. The Contract will terminate on September 30, 2026, or upon written request of either party with 30 calendar days' written notice whichever occurs earlier. This Contract may only be amended or extended by mutual written agreement of the parties.

7. NOTICE

Notice given under the terms of this contract shall be sent to the following:

Brazos County Community Supervision and Corrections Department

Jennifer Goerig, CSCD Director

321 E. 26th Street, Suite 300

Bryan, Texas 77803

Email: jgoerig@brazoscountytexas.gov

Phone: 979-361-4429

Brazos County

Kyle Kacal, County Judge

200 S. Texas Avenue, Suite 332, Bryan, TX 77803

Email: kkacal@brazoscountytexas.gov

Phone: 979-361-4101

Either party may change its information in this section by giving the other party written notice and the date upon which the change will become effective.

8. CERTIFICATIONS

The Parties certify that (1) the Contract is authorized by the governing body of each party; (2) the purpose, terms, rights, and duties of the Parties are stated within the Contract; and (3) each party will make payments for the performance of governmental functions or services from current revenues available to the paying party.

The undersigned signatories have full authority to enter into this Contract on behalf of the respective Parties.

BRAZOS COUNTY

CSCD



Kyle Kacal
County Judge



Jennifer Goerig
CSCD Director

8/12/2025
Date

7/31/25
Date

ATTEST:



Karen McQueen
County Clerk

8/12/2025
Date



**BRAZOS COUNTY
BRYAN, TEXAS**

DEPARTMENT: Road and Bridge NUMBER: CC-2026-Comcast-IGN-Koppe
Bridge-Meadowcreek Subdivision

DATE OF COURT MEETING: 6/23/2026

ITEM: Consider and take action on the Comcast utility permit to install 2-inch conduit by directional bore within the right-of-way of following County Roads. Sites are located in Precinct 1.

- a. I & GN Road – 727 feet in ROW and 2 crossings
- b. Koppe Bridge Road – 2,845 feet in ROW and 6 crossings
- c. Meadow Creek Drive – 1 crossing
- d. Faircrest - 2 crossings
- e. Sagewood Drive - 3 crossings
- f. Piedmont Lane - 1 crossing
- g. Meredith Drive - 2 crossings
- h. Cloud Lane - 3 crossings
- i. Arrow Crest Drive - 1 crossing
- j. Stewart Drive - 2 crossings

TO: Commissioners Court

FROM: Joe Salvato

DATE: 06/03/2026

FISCAL IMPACT: False

BUDGETED: False

DOLLAR AMOUNT: \$0.00

Brazos County considers Book End Bend and Clayton Lane as PRIVATE, therefore NO permit will be issued for these roadways. Conduits and appurtenances within Meadowcreek Subdivision MUST be placed within the platted Public Utility Easement (PUE)

Department requesting agenda item: Road and Bridge

Department impacted by agenda item: Road and Bridge

Brief explanation of agenda item and if in current year budget: Permit allows Comcast to install fiber optic conduit and construct road bores within right-of-way of I&GN – 727' and 2 bores; Koppe Bridge – 2,845' and 6 bores;

NOTES/EXCEPTIONS: Meadow Creek - 1 bore; Faircrest - 2 bores; Sagewood - 3 bores; Piedmont - 1 bore; Meredith - 2 bores; Cloud - 3 bores; Arrow Crest - 1 bore; Stewart - 2 bores

Brazos County has NO financial responsibility in project.

Consequences for failing to approve agenda item: Less customer choice for internet

Deadline for agenda item approval: As soon as possible

Site of work being performed: Precinct 1 - I & GN Road, Koppe Bridge Road, Meadow Creek Drive, Faircrest, Sagewood Drive, Piedmont Lane, Meredith Drive, Cloud Lane, Arrow Crest Drive and Stewart Drive

ATTACHMENTS:

File Name

Description

Type

Backup Material

[Utility Permit-Comcast-IGN-Koppe Bridge-Meadowcreek Subdivision.pdf](#)

Utility Permit-Comcast-IGN-Koppe Bridge-Meadwo creek Subdivision

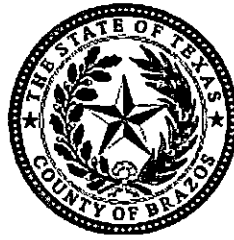

**BRAZOS COUNTY
BRYAN, TEXAS**

DEPARTMENT: Road and Bridge NUMBER: CC-2026-Comcast-IGN-Koppe Bridge-Meadowcreek Subdivision

DATE OF COURT MEETING: 6/23/2026

ITEM: Consider and take action on the Comcast utility permit to install 2-inch conduit by directional bore within the right-of-way of following County Roads. Sites are located in Precinct 1.

- a. I & GN Road – 727 feet in ROW and 2 crossings
- b. Koppe Bridge Road – 2,845 feet in ROW and 6 crossings
- c. Meadow Creek Drive – 1 crossing
- d. Faircrest - 2 crossings
- e. Sagewood Drive - 3 crossings
- f. Pidmont Lane - 1 crossing
- g. Meredith Drive - 2 crossings
- h. Cloud Lane - 3 crossings
- i. Arrow Crest Drive - 1 crossing
- j. Stewart Drive - 2 crossings

TO: Commissioners Court
 FROM: Joe Salvato
 DATE: 06/03/2026
 FISCAL IMPACT: False
 BUDGETED: False
 DOLLAR AMOUNT: \$0.00

APPROVED

 Duane Peters Date
 County Judge

Brazos County considers Book End Bend and Clayton Lane as PRIVATE, therefore NO permit will be issued for these roadways. Conduits and appurtenances within Meadowcreek Subdivision MUST be placed within the platted Public Utility Easement (PUE)

Department requesting agenda item: Road and Bridge
 Department impacted by agenda item: Road and Bridge
 Brief explanation of agenda item and if in current year budget: Permit allows Comcast to install fiber optic conduit and construct road bores within right-of-way of I&GN – 727' and 2 bores; Koppe Bridge – 2,845' and 6 bores;

NOTES/EXCEPTIONS: Meadow Creek - 1 bore; Faircrest - 2 bores; Sagewood - 3 bores; Pidmont - 1 bore; Meredith - 2 bores; Cloud - 3 bores; Arrow Crest - 1 bore; Stewart - 2 bores

Brazos County has NO financial responsibility in project.
 Consequences for failing to approve agenda item: Less customer choice for internet
 Deadline for agenda item approval: As soon as possible
 Site of work being performed: Precinct 1 - I & GN Road, Koppe Bridge Road, Meadow Creek Drive, Faircrest, Sagewood Drive, Pidmont Lane, Meredith Drive, Cloud Lane, Arrow Crest Drive and Stewart Drive

ATTACHMENTS:

<u>File Name</u>	<u>Description</u>	<u>Type</u>
------------------	--------------------	-------------

**NOTIFICATION OF PROPOSED INSTALLATION AND/OR REPAIRS
OF TELEPHONE FACILITIES AND DESIGNATING
PLACEMENT OF UTILITY IN COUNTY RIGHT OF WAY
TO: THE COUNTY ENGINEER OF BRAZOS COUNTY, TEXAS**

Comes now Comcast of Houston, LLC [company name], hereinafter referred to as "Company" a Texas [state] Corporation, with authority to transact business in Texas, acting by and through its duly authorized representative, and hereby notifies the County Engineer of its intent to lay, construct, maintain, repair and/or operate a telephone facility under, over, across and/or along certain County Roads as shown on drawings and diagrams attached hereto and said location described as follows:

Comcast proposes installing by directional bore a single 2-inch SDR-11 HDPE conduit with associated pedestals within the right-of-way of the following County Roads:

I & GN Road – 727 feet in ROW and 2 crossings
Koppe Bridge Road – 2,845 feet in ROW and 6 crossing
Meadow Creek Drive – 1 crossing
Faircrest – 2 crossings
Sagewood Drive – 3 crossings
Piedmont Lane – 1 crossing
Meredith Drive – 2 crossings
Cloud Lane – 3 crossings
Arrow Crest Drive – 1 crossing
Stewart Drive – 2 crossings

Project includes the installation of 24/48/144-count fiber optic cable at a minimum depth of 4-feet at all points and a minimum of 5-feet under roadways

The location and description of the proposed installation and appurtenances must be fully shown on detailed drawings attached to this Notification.

The Company shall commence actual construction/work in good faith within 60 days from the date of said permit and shall complete said construction /work within 10 working days. (COMPANY MUST FILL IN). If such construction is not begun by the 60th day, Company will be required to provide a new notice.

Company declares that prior to filing this application, it has ascertained the location of all existing utilities, both aerial and underground, and the filing of this application is prima facie evidence that the proposed installation will not conflict with any existing utility.

A copy of this notice shall be kept at the job site any time work is being performed.

In the event of deviation from this notice, the Brazos County Engineer's Office or its designated representative will be notified as soon as practicable.

Approval of County Engineer's Office may take as long as two weeks after complete application is received.

Failure to notify the County Engineer's Office within 24 hours of beginning construction shall constitute grounds for job shutdown.

By signing below, I certify that I am authorized to represent the Company listed below, and that the Company agrees to the conditions/provisions included in this notification.

Comcast of Houston LLC

Company Name

Justin Valentine

By:



Signature

Planning & Design Manager

Title

8590 West Tidwell Rd, Houston, Tx, 77040

Address

Phone Number 281-889-5413

Email:

dwenta@quasar.us

Justin_Valentine@comcast.com

shaneitra_jones@comcast.com

Ryan_Hawkins@comcast.com

kpiszczek@quasar.us

ACCEPTANCE OF NOTIFICATION

Brazos County offers no objection to the proposed location of the utility in the County right of way as shown by accompanying drawings and notice dated June 4, 2026 except as noted below:

EXCEPTIONS: Brazos County considers Book End Bend and Clayton Lane as PRIVATE, therefore NO permit will be issued for these roadway. Conduits and appurtenances within Meadowcreek Subdivision MUST be placed within the platted Public Utility Easements (PUE)

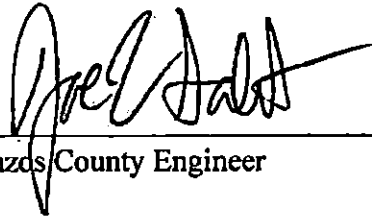
FOR  _____
Brazos County Engineer

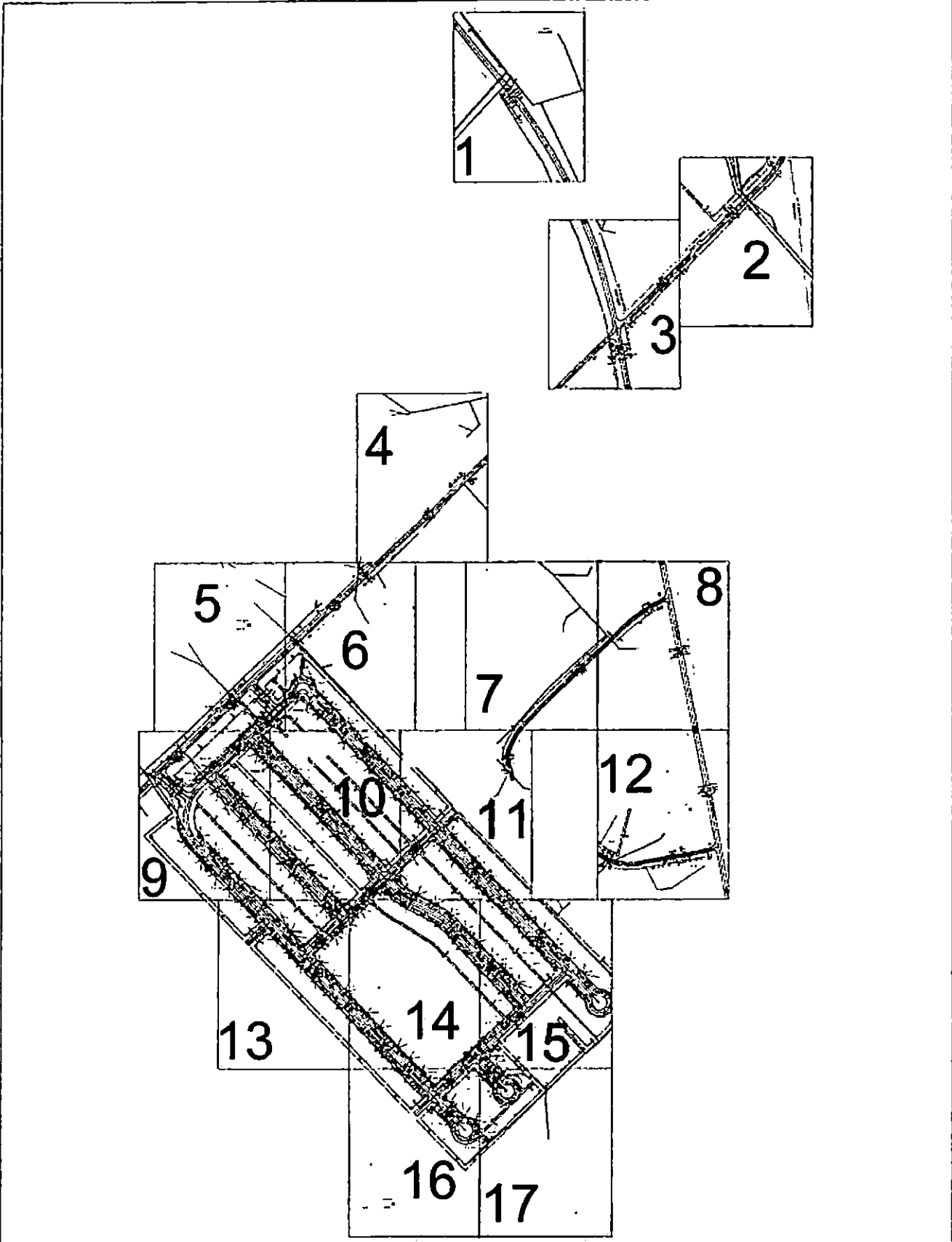

PREPARED BY
 QUASAR, INC.

COMCAST IS BORING AND INSTALLING NEW CONDUIT
 WITHIN THE RIGHT-OF-WAY AND UTILITY EASEMENT
 OWNED BY THE BRAZOS COUNTY.
 TOTAL: 25816ft

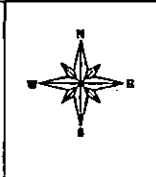

ENGINEERED FOR

 COMCAST

NO SCALE

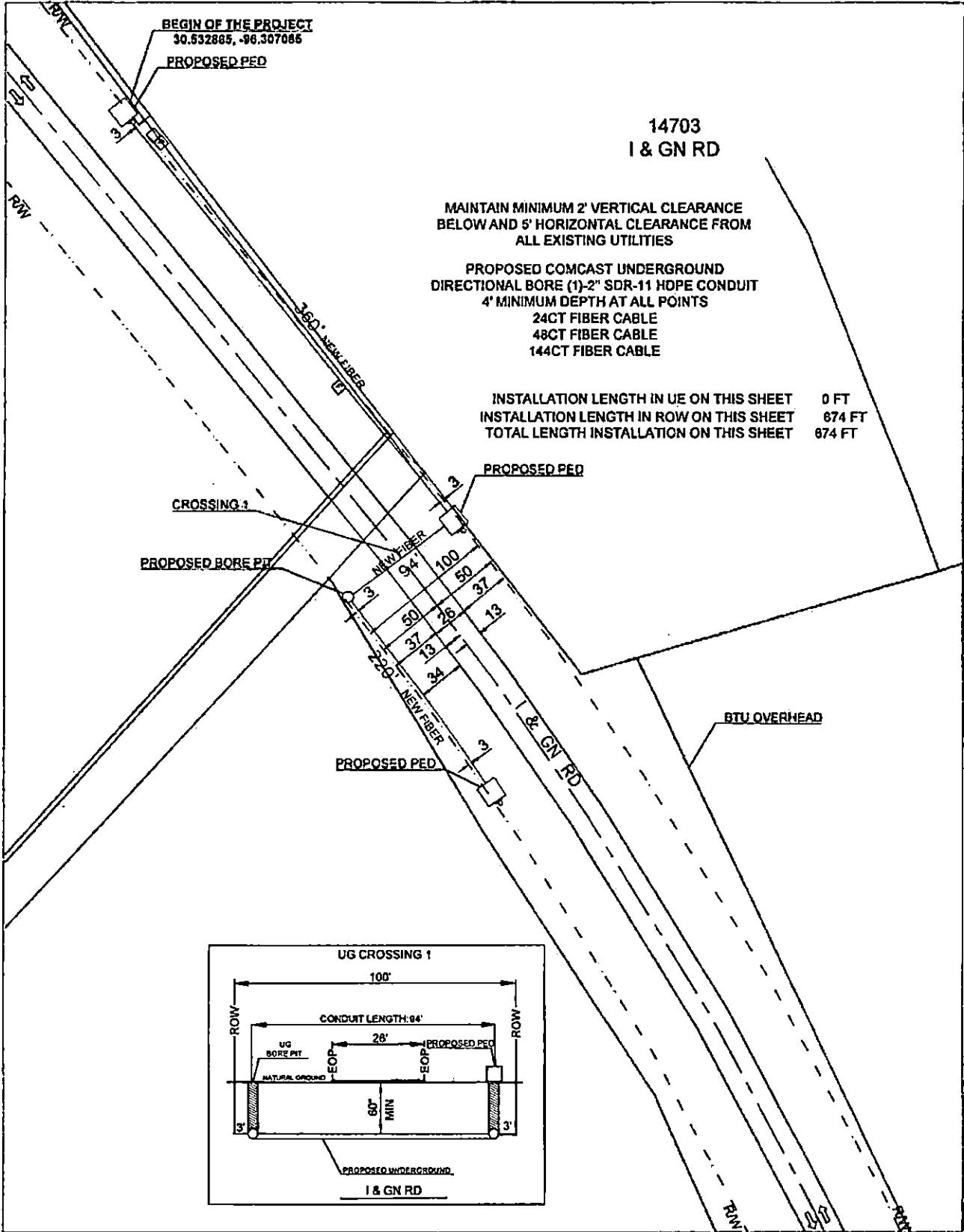
NO MATCH SHEET







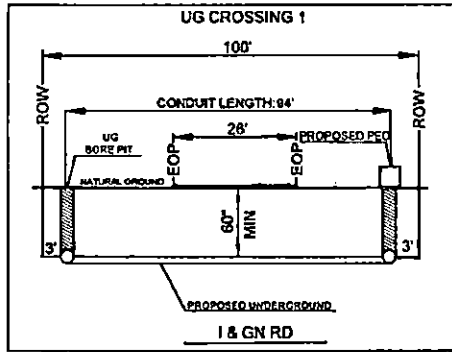



















NO MATCH SHEET

NO MATCH SHEET



NO MATCH SHEET

<p>PREPARED BY:</p>  <p>QUASAR, INC.</p>	<p>  EXISTING POLE  PROPOSED PEDESTAL  PROPOSED BORE PIT  WATER VALVE  MANHOLE  SEWER MANHOLE  STORM PIPE FEATURE  MARKER </p>	<p>  RIGHT OF WAY LINE  STORM SEWER LANE  WATER LANE  SANITARY SEWER LANE  BTU UNDERGROUND  TELCO LANE  PROPOSED RISER <p> RW - RIGHT OF WAY EOP - EDGE OF PAVEMENT BOC - BACK OF CURB CL - CENTER LINE </p> </p>	<p>  PROPOSED AERIAL FIBER CABLE  PROPOSED BURIED FIBER (2" HDPE) WITH THE CABLE  PROPOSED DIRECTIONAL BORE  UTILITY EASEMENT  GAS LANE  PHONE PED  FIBER VAULT/TAMPER  WATER METER </p> <p> NOTES BORE HOLE TO BE FILLED SAME DAY VAULT HOLE TO BE FILLED SAME DAY ALL HOLE TO BE TAMPED AND BORED </p>	<p>ENGINEERED FOR</p>  <p>COMCAST</p>	<p> BRAZOS COUNTY I & GN RD TRANSPORT FIBER </p> <p>NO SCALE SHEET 1 OF 17</p>
---	---	--	--	--	--

NO MATCH SHEET

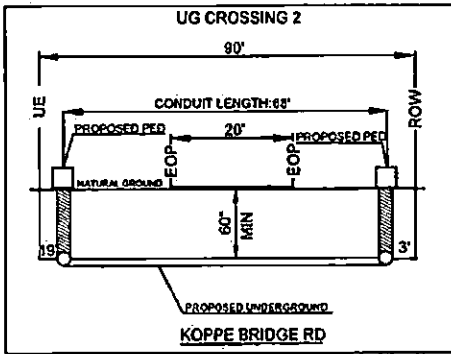
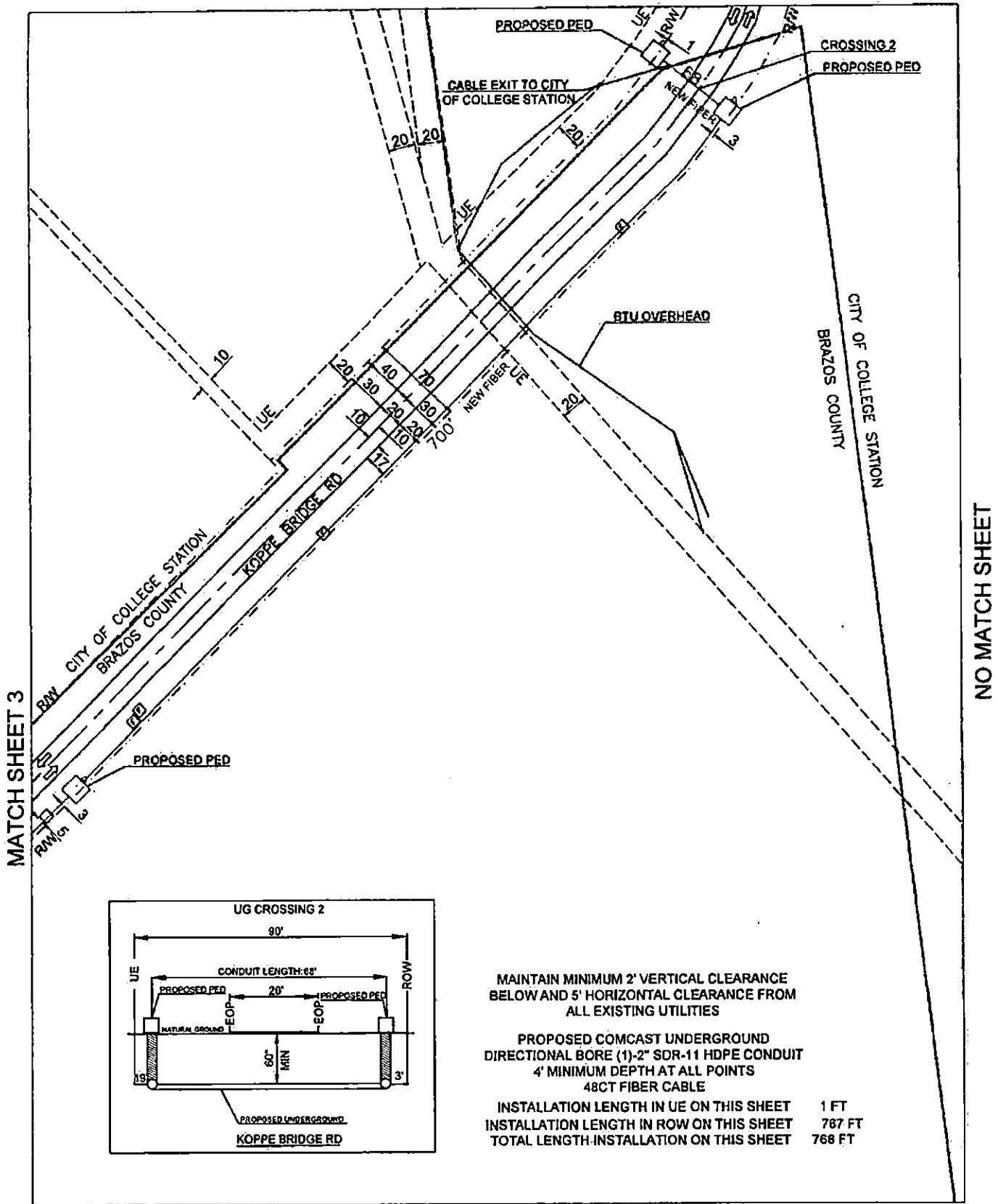

MAINTAIN MINIMUM 2' VERTICAL CLEARANCE BELOW AND 5' HORIZONTAL CLEARANCE FROM ALL EXISTING UTILITIES

PROPOSED COMCAST UNDERGROUND DIRECTIONAL BORE (1)-2" SDR-11 HDPE CONDUIT 4' MINIMUM DEPTH AT ALL POINTS 48CT FIBER CABLE

INSTALLATION LENGTH IN UE ON THIS SHEET 1 FT
 INSTALLATION LENGTH IN ROW ON THIS SHEET 787 FT
 TOTAL LENGTH INSTALLATION ON THIS SHEET 788 FT

NO MATCH SHEET

PREPARED BY 	EXISTING POLE PROPOSED PEDESTAL PROPOSED BORE PNT WATER VALVE FIRE HYDRANT MANHOLE SEWER MANHOLE STORM PIPE FEATURE MARKER	RIGHT OF WAY LINE STORM SEWER LANE WATER LANE SANITARY SEWER LANE STU UNDERGROUND STU OVERHEAD TELCO LANE PROPOSED RESER ROW - RIGHT OF WAY EOP - EDGE OF PAVEMENT BOC - BACK OF CURB CL - CENTER LINE	PROPOSED AERIAL FIBER CABLE PROPOSED DIRECTIONED FIBER (2)HOPE EXISTING CABLE PROPOSED DIRECTIONAL BORE UE - UTILITY EQUIPMENT GAS LANE PHONE PED FIBER VALVE MARKER WATER METER		ENGINEERED FOR: BRAZOS COUNTY
NOTES BORE HOLE TO BE FILLED SAME DAY WALK HOLE TO BE FILLED SAME DAY ALL HOLES TO BE TAMPED AND MOTTED					NO SCALE SHEET 2 OF 17

NO MATCH SHEET

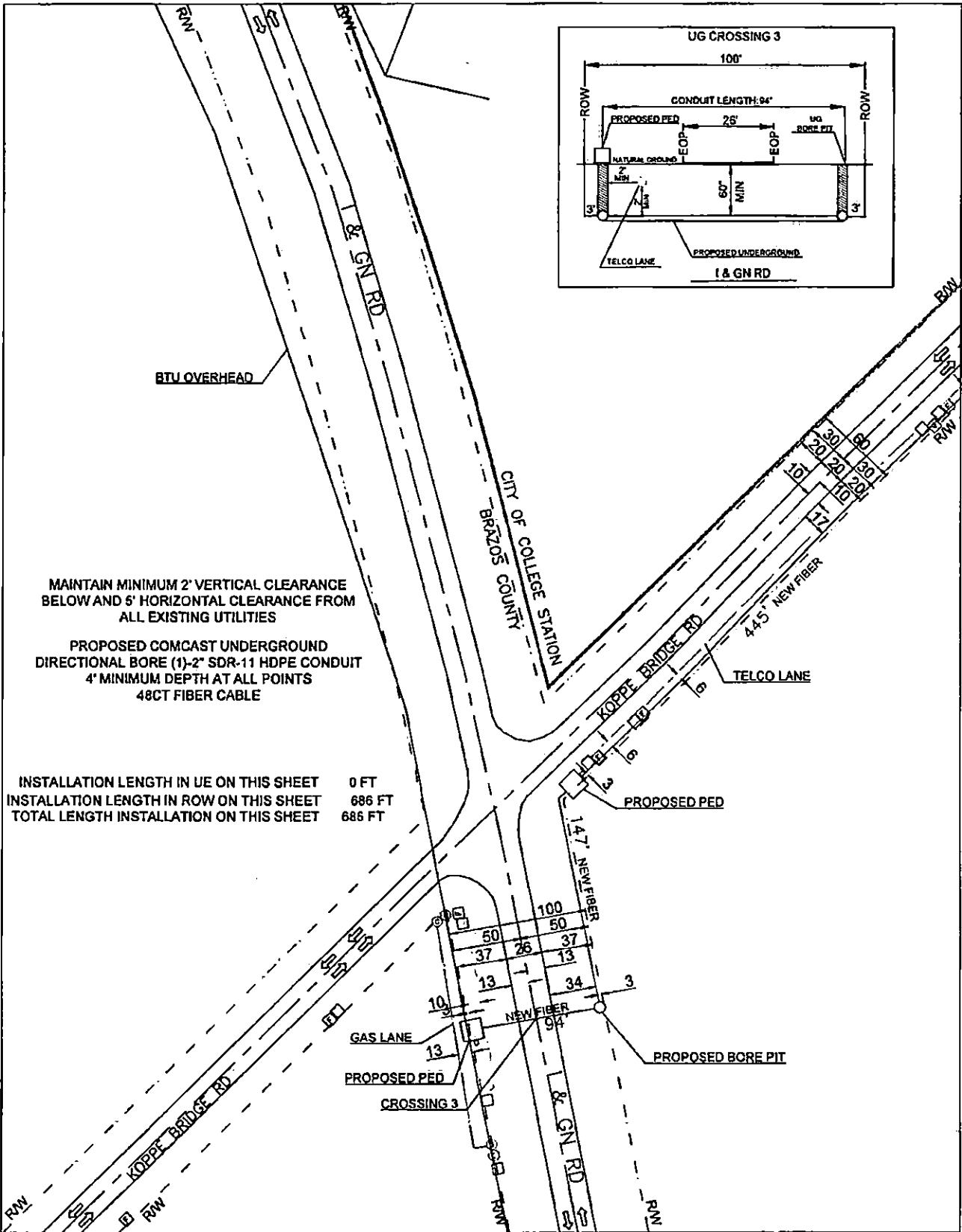

NO MATCH SHEET

MATCH SHEET 2

MAINTAIN MINIMUM 2' VERTICAL CLEARANCE BELOW AND 5' HORIZONTAL CLEARANCE FROM ALL EXISTING UTILITIES

PROPOSED COMCAST UNDERGROUND DIRECTIONAL BORE (1)-2" SDR-11 HDPE CONDUIT 4' MINIMUM DEPTH AT ALL POINTS 48CT FIBER CABLE

INSTALLATION LENGTH IN UE ON THIS SHEET 0 FT
 INSTALLATION LENGTH IN ROW ON THIS SHEET 686 FT
 TOTAL LENGTH INSTALLATION ON THIS SHEET 686 FT

NO MATCH SHEET

PREPARED BY 	EXISTING POLE PROPOSED PED/STAL PROPOSED BORE PIT WATER VALVE PIPE HYDRANT MANHOLE SEWER MANHOLE STORM PIPE FEATURE MARKER	RIGHT OF WAY LINE STORM SEWER LANE WATER LANE SANITARY SEWER LANE BTU UNDERGROUND BTU OVERHEAD TELCO LANE PROPOSED FIBER R/W - RIGHT OF WAY EOP - EDGE OF PAVEMENT BOC - BACK OF CURB CL - CENTER LINE	PROPOSED AERIAL FIBER CABLE PROPOSED DUBBED FIBER (FIBOP) EXISTING CABLE PROPOSED DIRECTIONAL BORE UE - UTILITY EASEMENT GAS LANE PHONE PED FIBER VALVE/TAP/Marker WATER METER NOTES: BORE HOLE TO BE FILLED SAME DAY VALVE HOLE TO BE FILLED SAME DAY ALL HOLE TO BE TAMPED AND BODDED		ENGINEERED FOR 	BRAZOS COUNTY I & GN RD KOPPE BRIDGE RD TRANSPORT FIBER
	QUASAR, INC.	COMCAST	NO SCALE	SHEET 3 OF 17		

NO MATCH SHEET

NO MATCH SHEET

NO MATCH SHEET

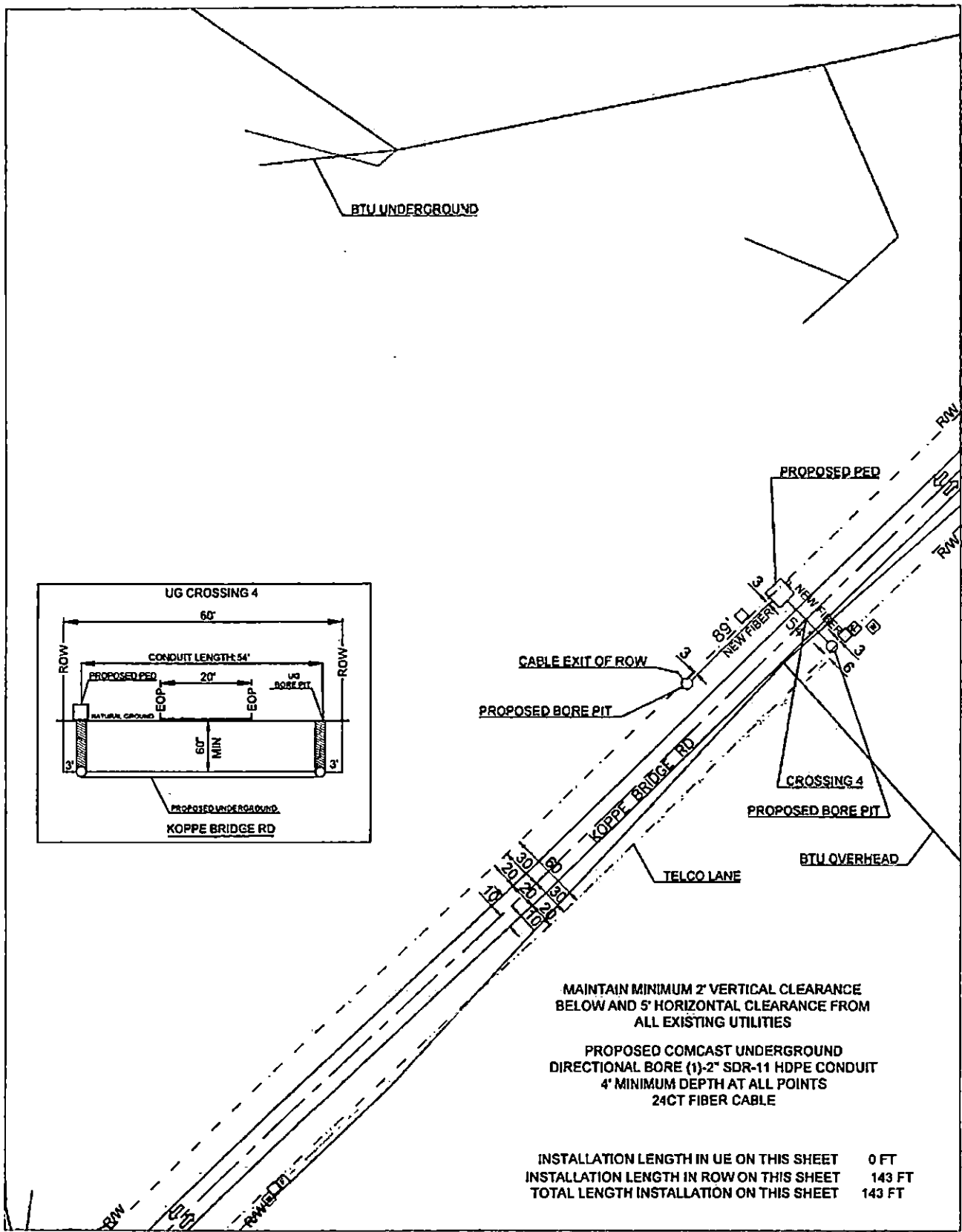
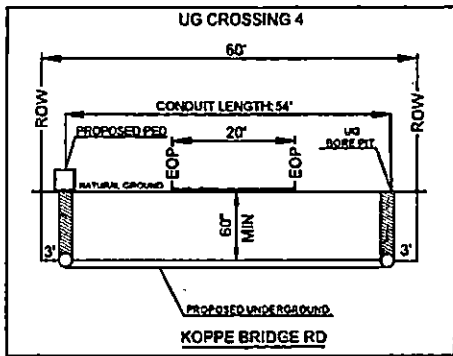

MAINTAIN MINIMUM 2' VERTICAL CLEARANCE
BELOW AND 5' HORIZONTAL CLEARANCE FROM
ALL EXISTING UTILITIES

PROPOSED COMCAST UNDERGROUND
DIRECTIONAL BORE (1)-2" SDR-11 HDPE CONDUIT
4' MINIMUM DEPTH AT ALL POINTS
24CT FIBER CABLE

INSTALLATION LENGTH IN UE ON THIS SHEET 0 FT
INSTALLATION LENGTH IN ROW ON THIS SHEET 143 FT
TOTAL LENGTH INSTALLATION ON THIS SHEET 143 FT

MATCH SHEET 6

PREPARED BY 	X EXISTING POLE PROPOSED PEDESTAL PROPOSED BORE PIT WATER VALVE FIRE HYDRANT MANHOLE SEWER MANHOLE STORM PIPE FEATURE MARKER	--- RIGHT OF WAY LINE --- STORM SEWER LANE --- WATER LANE --- SANITARY SEWER LANE --- BTU UNDERGROUND --- BTU OVERHEAD --- TELCO LANE --- PROPOSED MESER --- ROW - RIGHT OF WAY --- EOP - EDGE OF PAVEMENT --- BOC - BACK OF CURB --- CL - CENTER LINE	--- PROPOSED AERIAL FIBER CABLE --- PROPOSED CURED FIBER (TYHOPE) --- EXISTING CABLE --- PROPOSED DIRECTIONAL BORE --- UE - UTILITY EASEMENT --- GAS LANE □ PHONE PED □ FIBER VALVEMARKER □ WATER METER		ENGINEERED FOR 	BRAZOS COUNTY KOPPE BRIDGE RD TRANSPORT FIBER
	NOTES BORE HOLE TO BE FILLED SAME DAY VALVE HOLE TO BE FILLED SAME DAY ALL HOLES TO BE TAMPED AND SOCCED	NO SCALE SHEET 4 OF 17				

NO MATCH SHEET

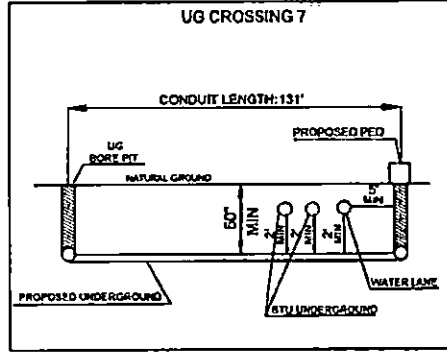
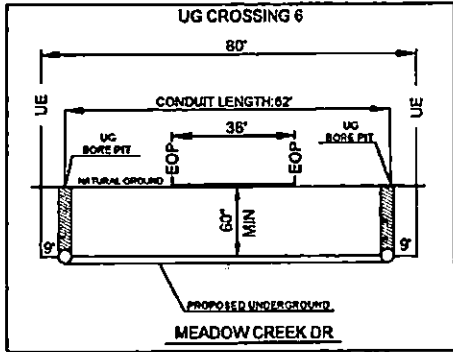
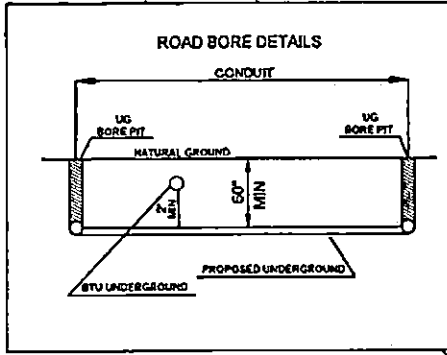
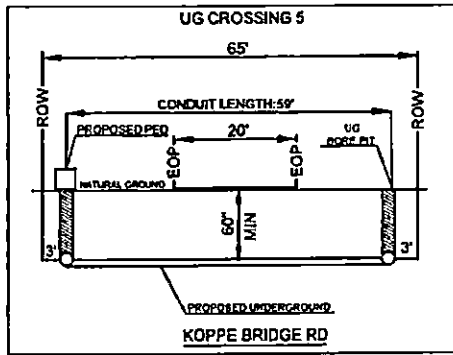

NO MATCH SHEET

MAINTAIN MINIMUM 2" VERTICAL CLEARANCE BELOW AND 5' HORIZONTAL CLEARANCE FROM ALL EXISTING UTILITIES

PROPOSED COMCAST UNDERGROUND DIRECTIONAL BORE (1)-2" SDR-11 HDPE CONDUIT
4" MINIMUM DEPTH AT ALL POINTS
24CT FIBER CABLE
48CT FIBER CABLE

INSTALLATION LENGTH IN UE ON THIS SHEET 346 FT
INSTALLATION LENGTH IN ROW ON THIS SHEET 914 FT
TOTAL LENGTH INSTALLATION ON THIS SHEET 1260 FT

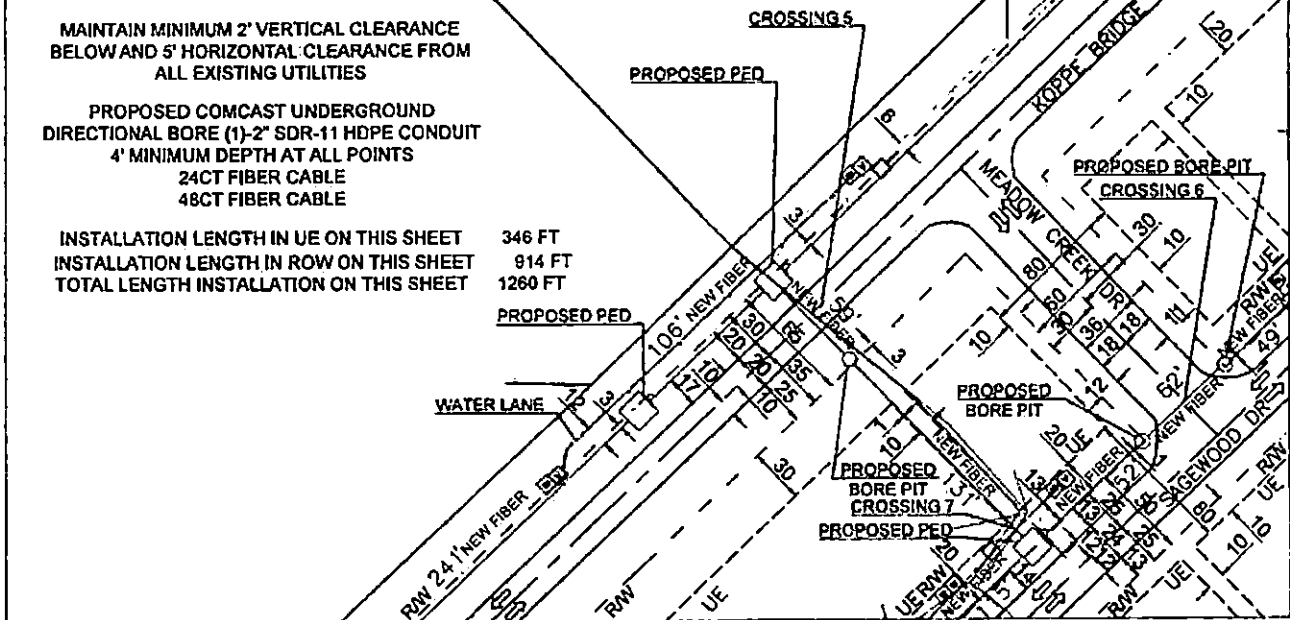

MATCH SHEET 6

MATCH SHEET 6

MATCH SHEET 9

MATCH SHEET 9

PREPARED BY: 	EXISTING POLE PROPOSED PEDESTAL PROPOSED BORE PIT WATER VALVE FIRE HYDRANT MANHOLE SEWER MANHOLE STORM PIPE FEATURE MARKER	--- RIGHT OF WAY LINE --- STORM SEWER LANE --- WATER LANE --- SANITARY SEWER LANE --- BTU UNDERGROUND --- BTU OVERHEAD --- TELCO LANE --- PROPOSED RISER --- ROW - RIGHT OF WAY --- EOP - EDGE OF PAVEMENT --- EOC - BACK OF CURB --- CL - CENTER LINE	--- PROPOSED AERIAL FIBER CABLE --- PROPOSED BURIED FIBER (HDPE) EXISTING CABLE --- PROPOSED DIRECTIONAL BORE --- UE - UTILITY EASEMENT --- GAS LANE --- PHONE PED --- FIBER VALVE MARKER --- WATER METER --- GAS VALVE MARKER		ENGINEERED FOR 	BRAZOS COUNTY KOPPE BRIDGE RD MEADOW CREEK DR SAGEWOOD DR TRANSPORT FIBER
	QUASAR, INC.	NOTES: BORE HOLE TO BE FILLED SAME DAY VALVE HOLE TO BE FILLED SAME DAY ALL HOLE TO BE TAMPED AND SOCKED	NO SCALE SHEET 8 OF 17			

MATCH SHEET 4

MAINTAIN MINIMUM 2' VERTICAL CLEARANCE BELOW AND 5' HORIZONTAL CLEARANCE FROM ALL EXISTING UTILITIES

PROPOSED COMCAST UNDERGROUND DIRECTIONAL BORE (1)-2" SDR-11 HDPE CONDUIT
4' MINIMUM DEPTH AT ALL POINTS
24CT FIBER CABLE
48CT FIBER CABLE

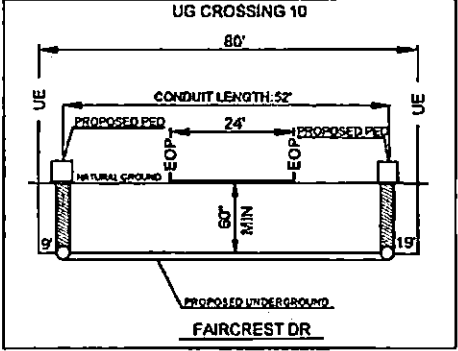
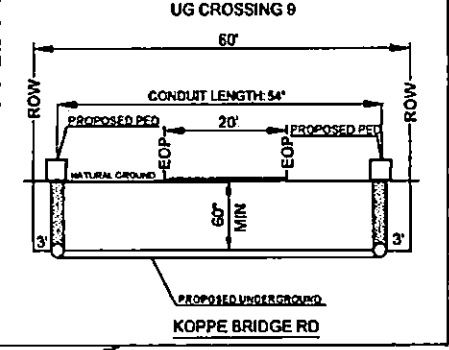
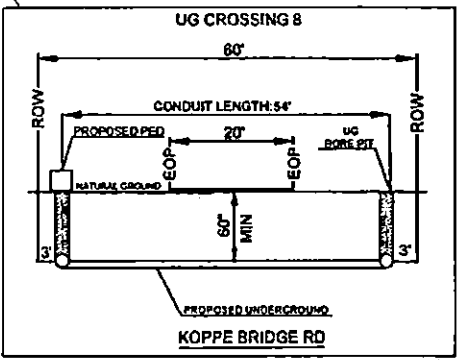
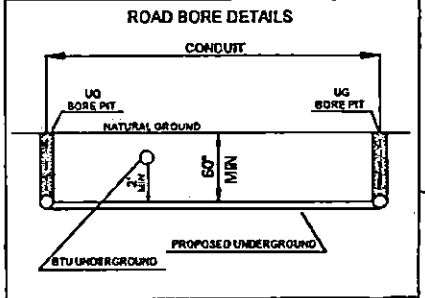
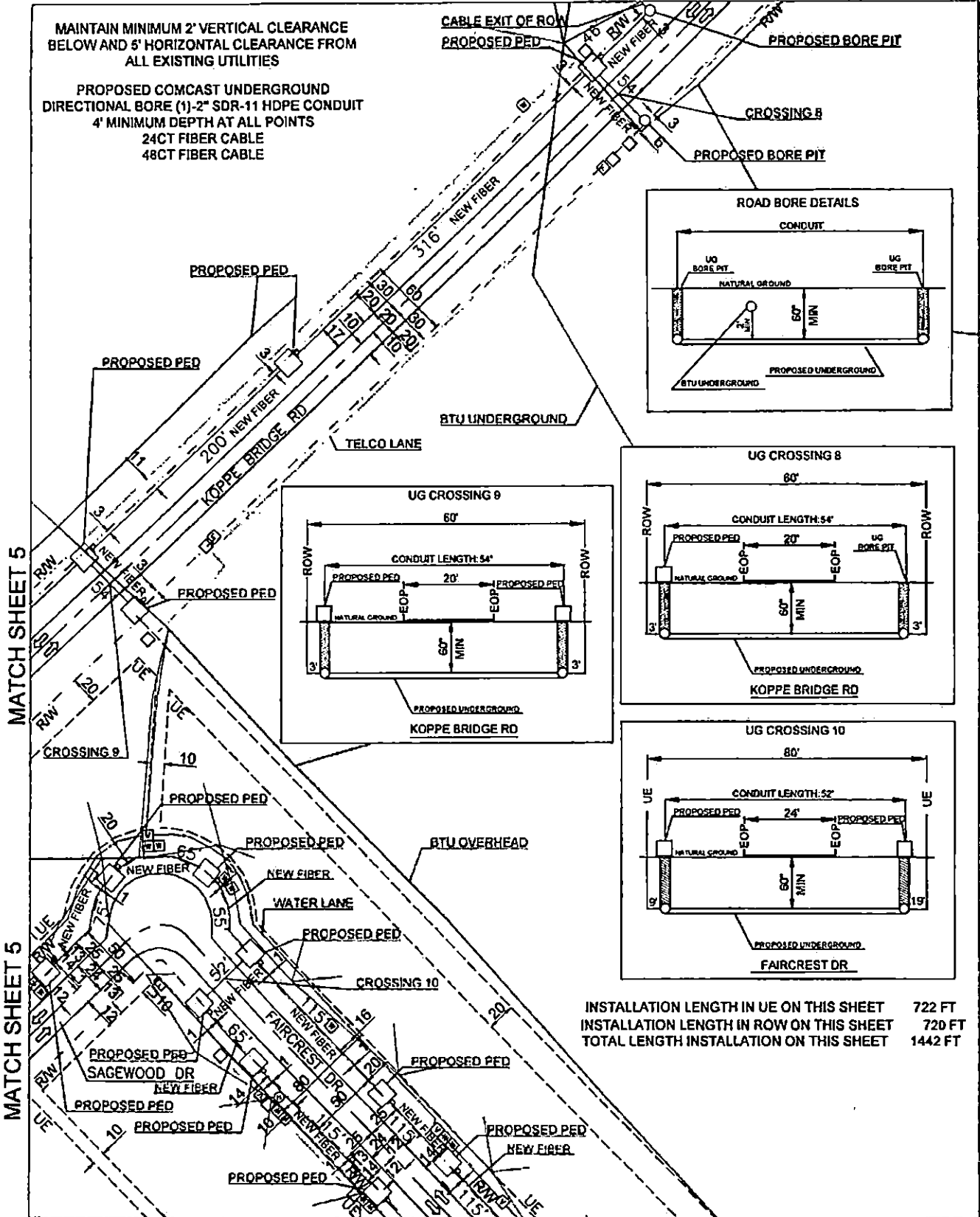

INSTALLATION LENGTH IN UE ON THIS SHEET 722 FT
INSTALLATION LENGTH IN ROW ON THIS SHEET 720 FT
TOTAL LENGTH INSTALLATION ON THIS SHEET 1442 FT

MATCH SHEET 5

MATCH SHEET 5

NO MATCH SHEET

MATCH SHEET 10

PREPARED BY 	EXISTING POLE PROPOSED PEDESTAL 18"x3'x24" PROPOSED BORE PIT 4'x4' WATER VALVE FIRE HYDRANT MANHOLE SEWER MANHOLE STORM PIPE FEATURE MARKER	--- RIGHT OF WAY LINE --- 8" FORM SEWER LANE --- WATER LANE --- SANITARY SEWER LANE --- BTU UNDERGROUND --- BTU OVERHEAD --- TELCO LANE --- PROPOSED FIBER --- ROW - FRONT OF WALK --- EOP - EDGE OF PAVEMENT --- BOP - BACK OF CURB --- CL - CENTER LINE	--- PROPOSED AERIAL FIBER CABLE --- PROPOSED BARED FIBER (7-FOPE) --- EXISTING CABLE --- PROPOSED DIRECTIONAL BORE --- UE - UTILITY EASEMENT --- GAS LANE --- PHONE PED --- FIBER VALVE MARKER --- WATER METER		ENGINEERED FOR 	BRAZOS COUNTY KOPPE BRIDGE RD FAIRCREST DR SAGEWOOD DR TRANSPORT FIBER
	NOTES: BORE HOLE TO BE FILLED SAME DAY VALVE HOLE TO BE FILLED SAME DAY ALL HOLES TO BE TAMPED AND ROODED	NO SCALE SHEET 8 OF 17				

NO MATCH SHEET

MAINTAIN MINIMUM 2' VERTICAL CLEARANCE
BELOW AND 5' HORIZONTAL CLEARANCE FROM
ALL EXISTING UTILITIES

PROPOSED COMCAST UNDERGROUND
DIRECTIONAL BORE (1)-2" SDR-11 HDPE CONDUIT
4' MINIMUM DEPTH AT ALL POINTS
24CT FIBER CABLE

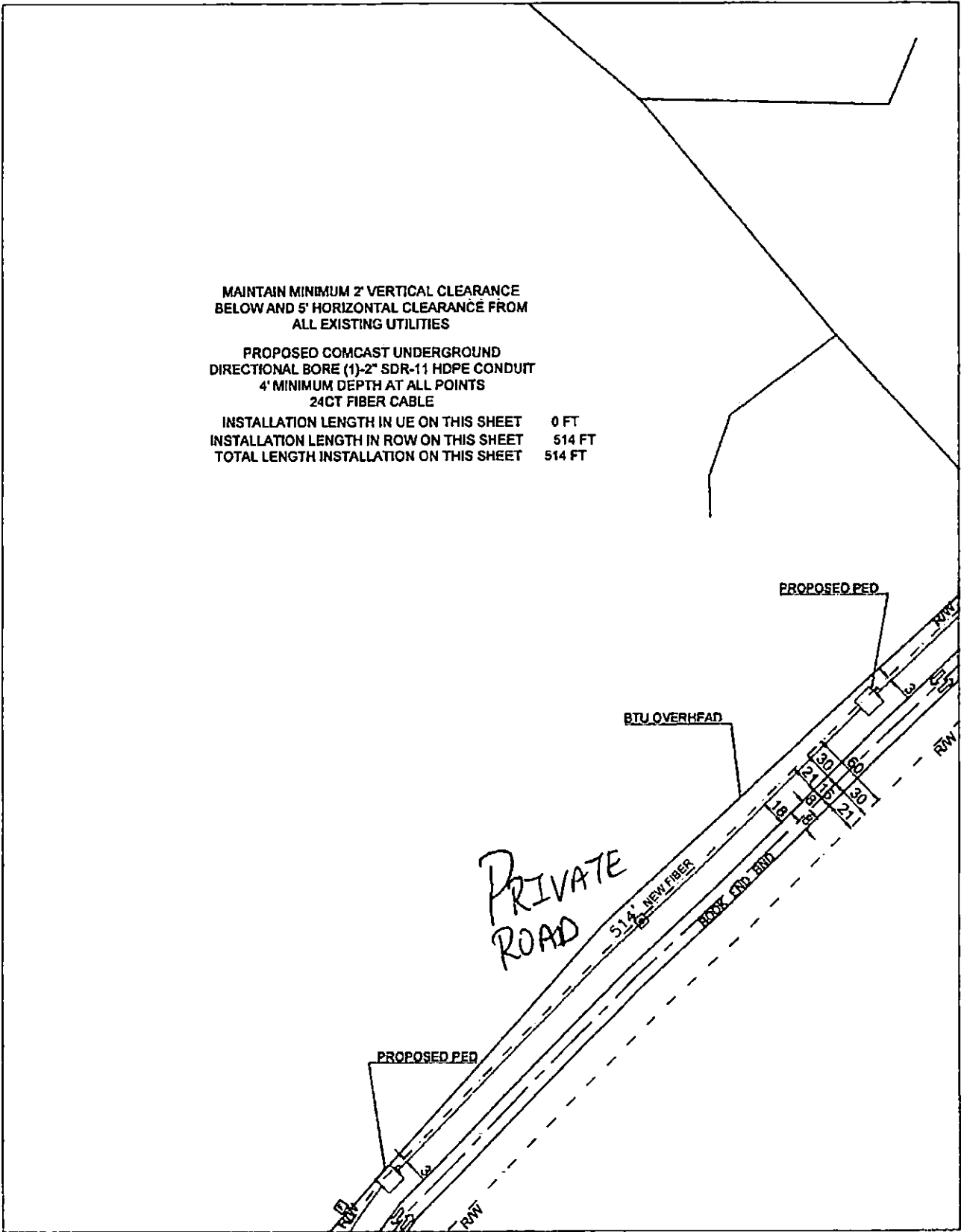

INSTALLATION LENGTH IN UE ON THIS SHEET 0 FT
INSTALLATION LENGTH IN ROW ON THIS SHEET 514 FT
TOTAL LENGTH INSTALLATION ON THIS SHEET 514 FT

NO MATCH SHEET



MATCH SHEET 8

MATCH SHEET 11

<p>PREPARED BY</p>	<p>EXISTING POLE PROPOSED PEDESTAL PROPOSED BORE PIT WATER VALVE FIRE HYDRANT MANHOLE SEWER MANHOLE STORM PIPE FEATURE MARKER</p>	<p>RIGHT OF WAY LINE STORM SEWER LANE WATER LANE SANITARY & OTHER LANE STU UNDERGROUND BTU OVERHEAD TELECO LANE PROPOSED FIBER RWY - RIGHT OF WAY LOP - EDGE OF PAVEMENT BOC - BACK OF CURB CL - CENTERLINE</p>	<p>PROPOSED AERIAL FIBER CABLE PROPOSED BURIED FIBER (2" HDPE) EXISTING CABLE PROPOSED DIRECTIONAL BORE UE - UTILITY EASEMENT GAS LANE PHONE PED FIBER VALVE MARKER WATER METER</p>	<p>ENGINEERED FOR</p> 	<p>BRAZOS COUNTY BOOK END BND TRANSPORT FIBER</p>
 <p>QUASAR, INC.</p>	<p>NOTES: BORE HOLE TO BE FILLED SAME DAY VAULT HOLE TO BE FILLED SAME DAY ALL HOLES TO BE TAMPED AND BODDED</p>		<p>COMCAST</p>	<p>NO SCALE SHEET 7 OF 17</p>	

NO MATCH SHEET

MAINTAIN MINIMUM 2' VERTICAL CLEARANCE BELOW AND 5' HORIZONTAL CLEARANCE FROM ALL EXISTING UTILITIES

PROPOSED COMCAST UNDERGROUND DIRECTIONAL BORE (1)-2" SDR-11 HDPE CONDUIT 4" MINIMUM DEPTH AT ALL POINTS 24CT FIBER CABLE

INSTALLATION LENGTH IN UE ON THIS SHEET 0 FT
 INSTALLATION LENGTH IN ROW ON THIS SHEET 537 FT
 TOTAL LENGTH INSTALLATION ON THIS SHEET 537 FT

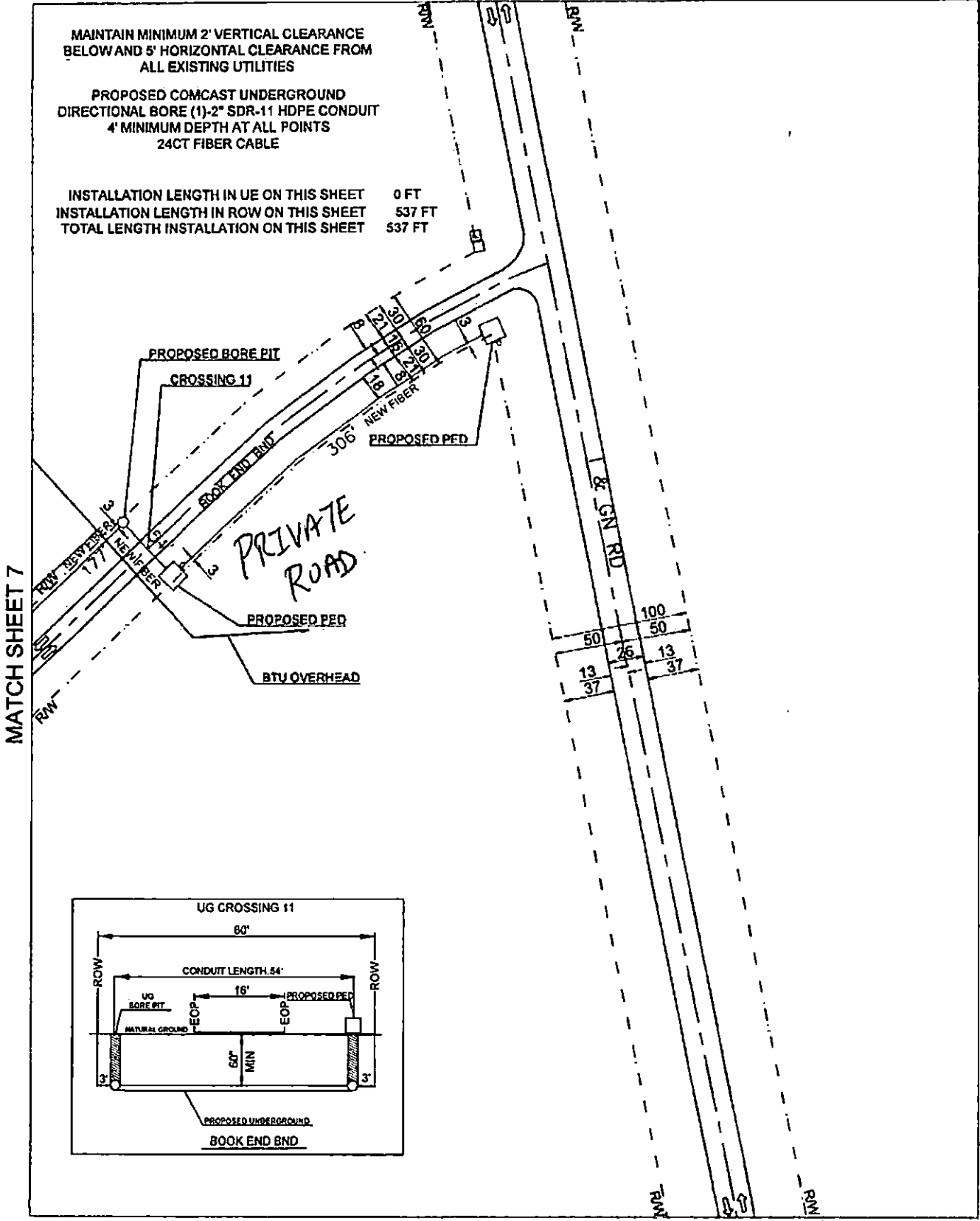

MATCH SHEET 7

NO MATCH SHEET

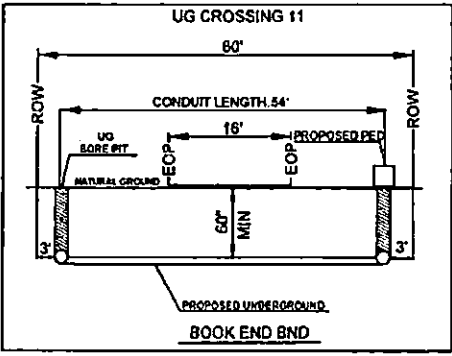

MATCH SHEET 12

PREPARED BY: 	EXISTING POLE PROPOSED FIBER PIT PROPOSED BORE PIT WATER VALVE FIRE HYDRANT MANHOLE SEWER MANHOLE STORM PIPE FEATURE MARKER	RIGHT OF WAY LINE STORM SEWER LANE WATER LANE SANITARY SEWER LANE BTU UNDERGROUND BTU OVERHEAD TELCO LANE PROPOSED RESER ROW - RIGHT OF WAY EOP - EDGE OF PAVEMENT BOC - BACK OF CURB CL - CENTER LINE	PROPOSED AERIAL FIBER CABLE PROPOSED BURIED FIBER (OVERHEAD) EXISTING CABLE PROPOSED DIRECTIONAL BORE UE - UTILITY EASEMENT GAS LANE PHONE PED FIBER VALVE/MARKER WATER METER NOTES BORE HOLE TO BE FILLED SAME DAY VALVE HOLE TO BE FILLED SAME DAY ALL HOLE TO BE TAMPED AND GOODDED		ENGINEERED FOR: 	BRAZOS COUNTY BOOK END BND TRANSPORT FIBER
	NO SCALE	SHEET 8 OF 11				

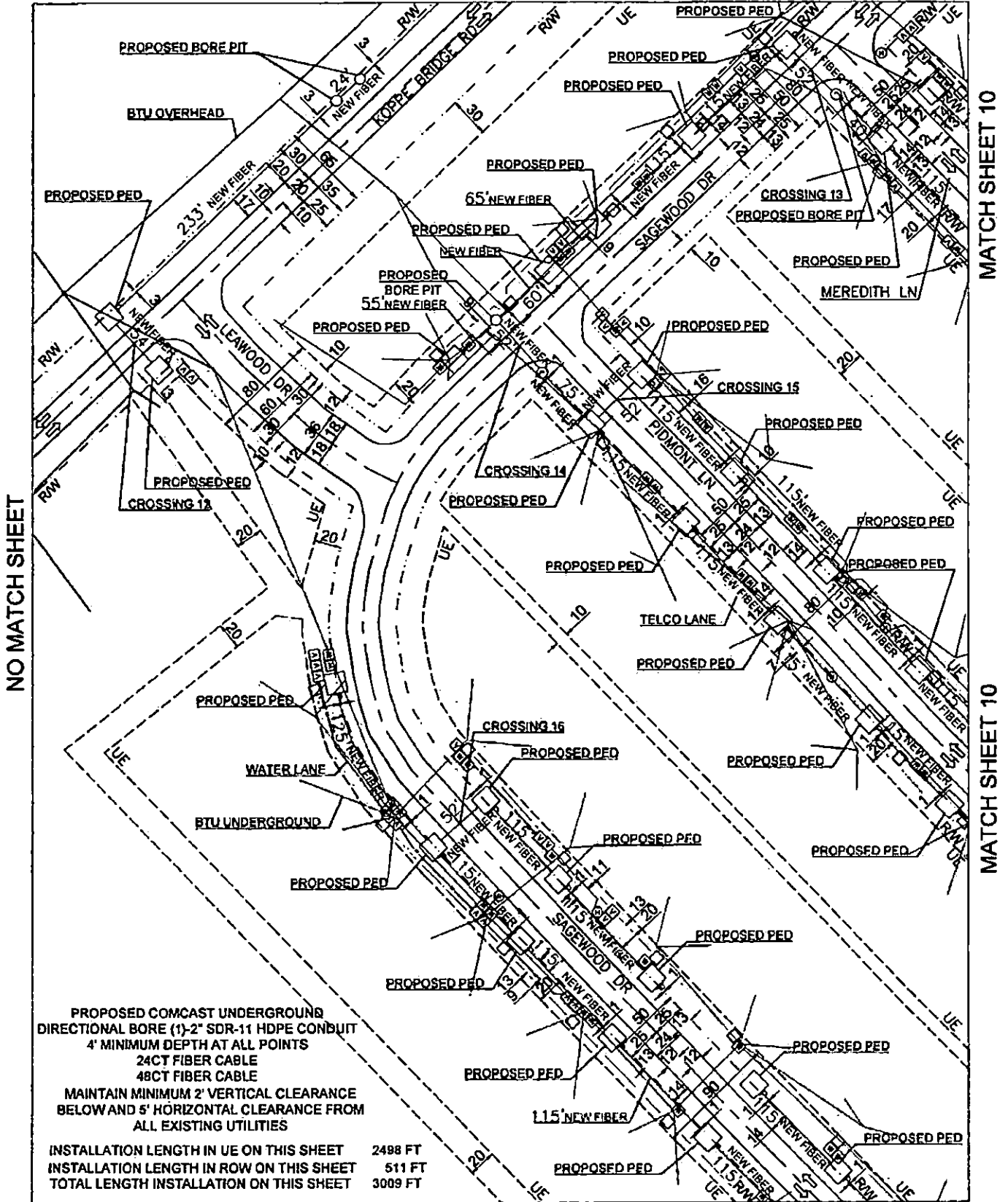

NO MATCH SHEET

MATCH SHEET 10

MATCH SHEET 10

PROPOSED COMCAST UNDERGROUND
 DIRECTIONAL BORE (1'-2" SDR-11 HDPE CONDUIT
 4' MINIMUM DEPTH AT ALL POINTS
 24CT FIBER CABLE
 48CT FIBER CABLE
 MAINTAIN MINIMUM 2' VERTICAL CLEARANCE
 BELOW AND 5' HORIZONTAL CLEARANCE FROM
 ALL EXISTING UTILITIES

INSTALLATION LENGTH IN UE ON THIS SHEET 2488 FT
 INSTALLATION LENGTH IN ROW ON THIS SHEET 511 FT
 TOTAL LENGTH INSTALLATION ON THIS SHEET 3009 FT

PREPARED BY: 	EXISTING POLE PROPOSED PEDESTAL PROPOSED BORE PIT WATER VALVE FIRE HYDRANT MANHOLE STORM PIPE FEATURE MARKER	RIGHT OF WAY LINE STORM SEWER LANE WATER LANE SANITARY SEWER LANE BTU UNDERGROUND BTU OVERHEAD TELCO LANE PROPOSED FIBER ROW - RIGHT OF WAY TOP - EDGE OF PAVEMENT BOC - BACKS OF CURB CL - CENTER LINE	PROPOSED AERIAL FIBER CABLE PROPOSED BURIED FIBER (CHOPED) EXISTING CABLE PROPOSED DIRECTIONAL BORE UE - UTILITY EASEMENT GAS LANE PHONE PED FIBER VALVE/MARKER WATER METER NOTES: BORE HOLE TO BE FILLED SAME DAY VALVE HOLE TO BE FILLED SAME DAY ALL HOLES TO BE TAMPED AND BODDED		ENGINEERED FOR 	BRAZOS COUNTY MEREDITH LN SAGEWOOD DR KOPPE BRIDGE RD PIDMONT LN TRANSPORT FIBER
	NO SCALE	SHEET 9 OF 11				

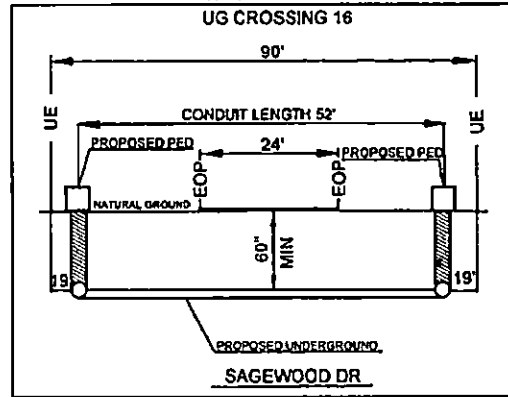
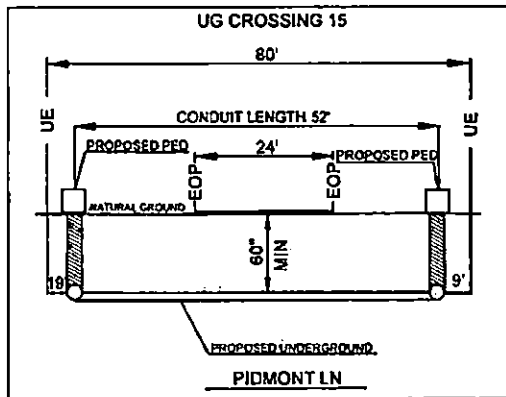
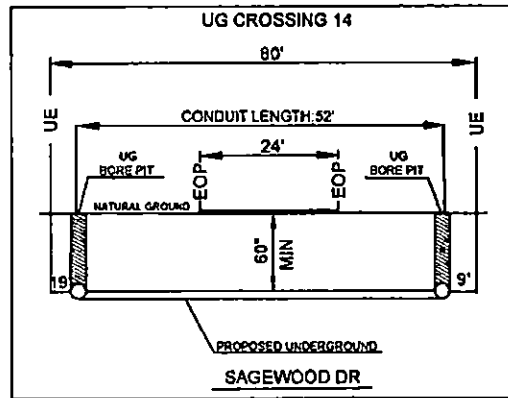
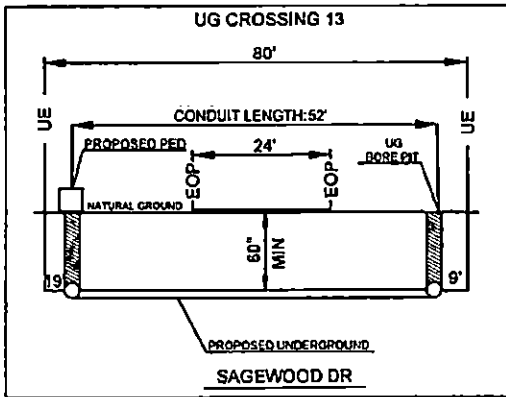
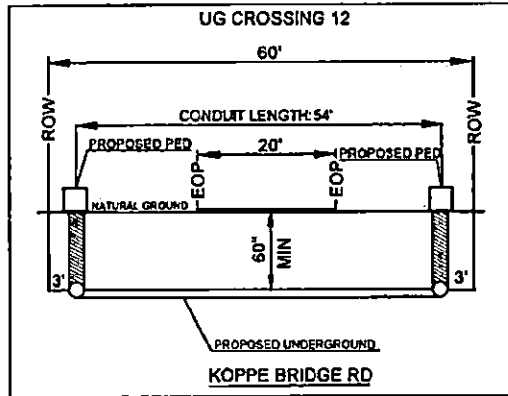
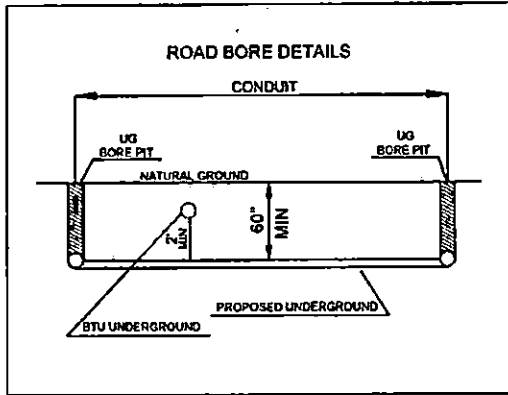

MATCH SHEET 6

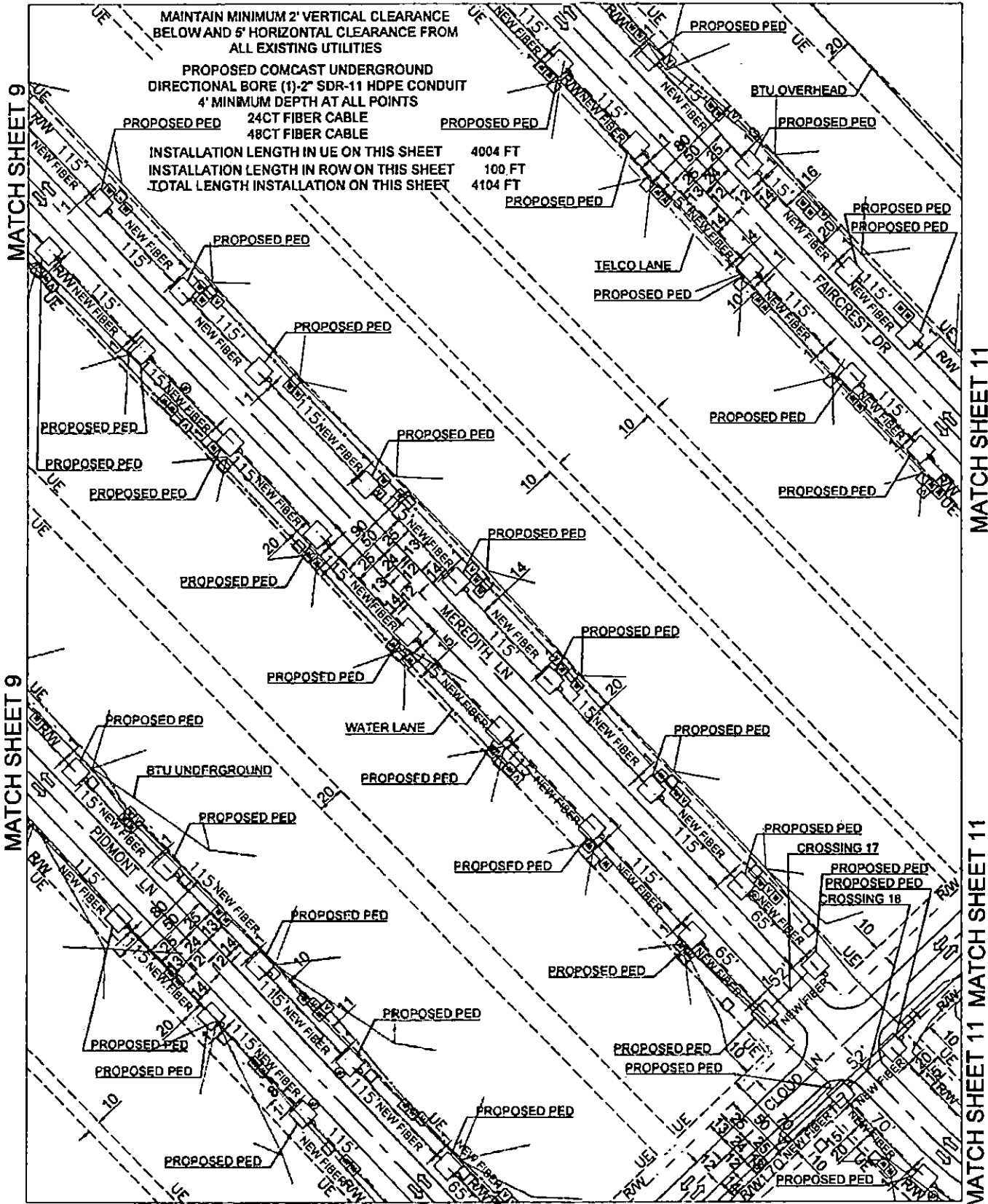

MAINTAIN MINIMUM 2' VERTICAL CLEARANCE
BELOW AND 5' HORIZONTAL CLEARANCE FROM
ALL EXISTING UTILITIES

PROPOSED COMCAST UNDERGROUND
DIRECTIONAL BORE (1)-2" SDR-11 HDPE CONDUIT
4' MINIMUM DEPTH AT ALL POINTS

PROPOSED PED 24CT FIBER CABLE
48CT FIBER CABLE

INSTALLATION LENGTH IN UE ON THIS SHEET 4004 FT
INSTALLATION LENGTH IN ROW ON THIS SHEET 100 FT
TOTAL LENGTH INSTALLATION ON THIS SHEET 4104 FT

MATCH SHEET 9

MATCH SHEET 11

MATCH SHEET 9

MATCH SHEET 11 MATCH SHEET 11

MATCH SHEET 13

MATCH SHEET 14

PREPARED BY 	EXISTING POLE PROPOSED PEDESTAL PROPOSED BORE PIT WATER VALVE FIRE HYDRANT MANHOLE EDGE MANHOLE STORM PIPE FEATURE MARKER	RIGHT OF WAY LINE STORM SEWER LANE WATER LANE SANITARY SEWER LANE BTU UNDERGROUND BTU OVERHEAD TELCO LANE PROPOSED RISER ROW - EDGE OF PAVEMENT BOC - BACK OF CURB CL - CENTERLINE	PROPOSED AERIAL FIBER CABLE PROPOSED BURIED FIBER (HDPE) EXISTING CABLE PROPOSED DIRECTIONAL BORE UE - UTILITY EASEMENT GAS LANE PHONE PED FIBER VALVE/MARKER WATER METER NOTES: BORE HOLES TO BE FILLED SAME DAY VALVE HOLES TO BE FILLED SAME DAY ALL HOLES TO BE TAMPED AND BODDED		ENGINEERED FOR 	BRAZOS COUNTY FAIRCREST DR MEREDITH LN CLOUD LN TRANSPORT FIBER NO SCALE SHEET 10 OF 11

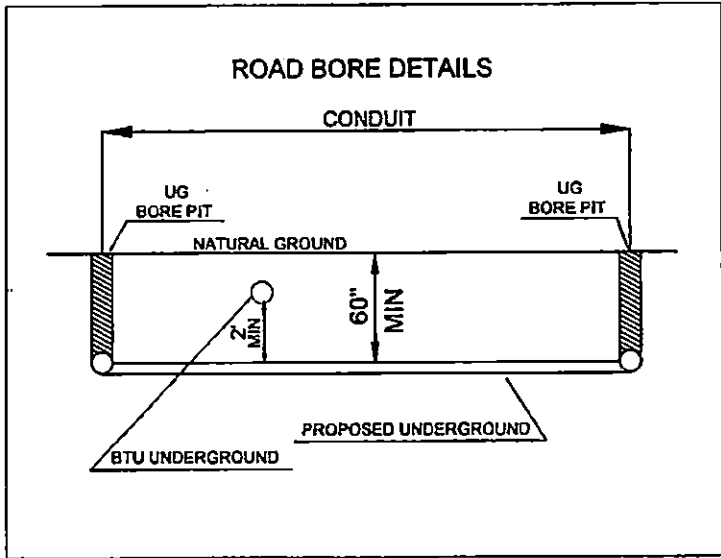
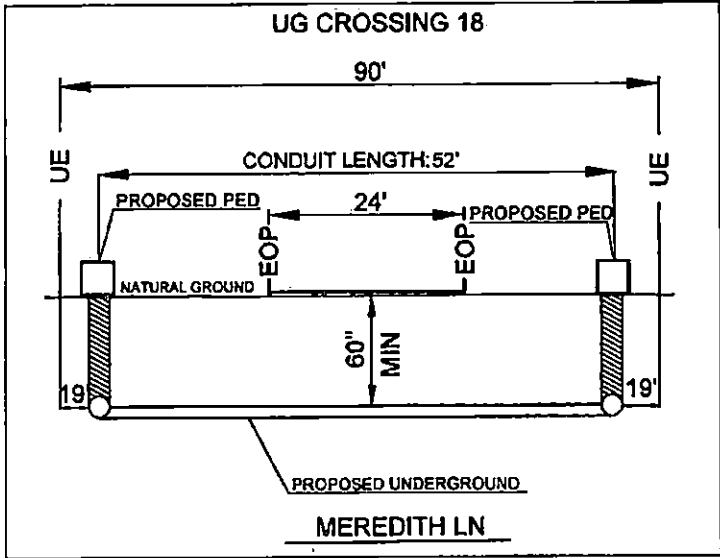
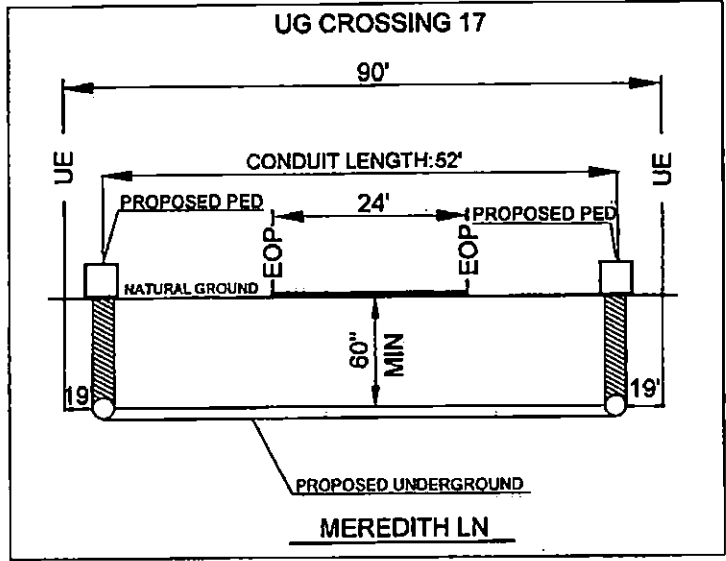

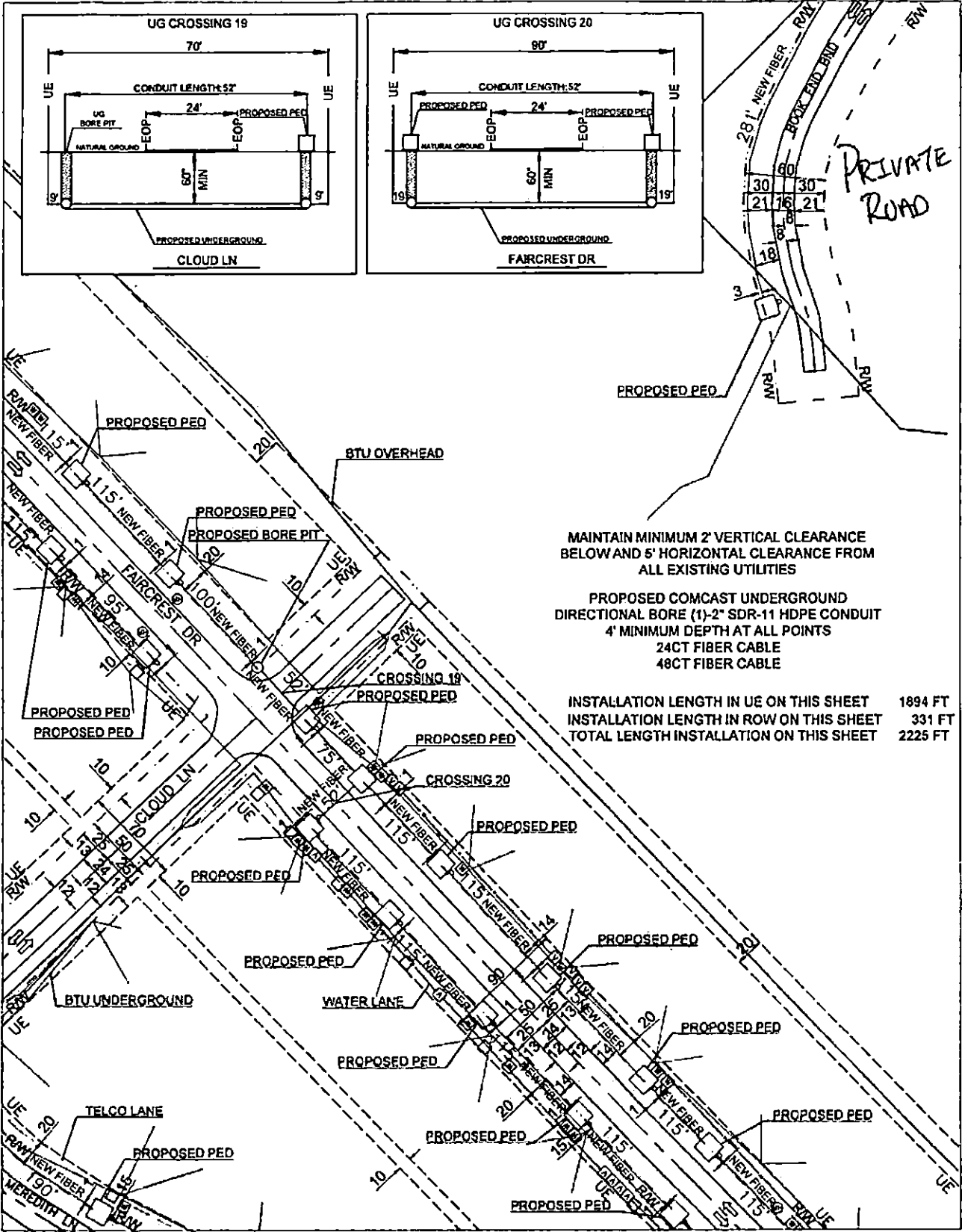

MAINTAIN MINIMUM 2' VERTICAL CLEARANCE BELOW AND 5' HORIZONTAL CLEARANCE FROM ALL EXISTING UTILITIES

PROPOSED COMCAST UNDERGROUND DIRECTIONAL BORE (1)-2" SDR-11 HDPE CONDUIT 4" MINIMUM DEPTH AT ALL POINTS
24CT FIBER CABLE
48CT FIBER CABLE

INSTALLATION LENGTH IN UE ON THIS SHEET 1894 FT
INSTALLATION LENGTH IN ROW ON THIS SHEET 331 FT
TOTAL LENGTH INSTALLATION ON THIS SHEET 2225 FT

MATCH SHEET 10

MATCH SHEET 10 MATCH SHEET 10

MATCH SHEET 14

MATCH SHEET 15

NO MATCH SHEET

PREPARED BY 	EXISTING POLE PROPOSED PEDESTAL PROPOSED BORE PIT WATER VALVE FIRE HYDRANT MANHOLE STREET MANHOLE STORM PIPE FEATURE MARKER	RIGHT OF WAY LINE STORM SEWER LANE WATER LANE SANITARY SEWER LANE BTU UNDERGROUND TELCO LANE PROPOSED RESER RW - RIGHT OF WAY EOP - EDGE OF PAVEMENT DOC - RANGE OF CURB CL - CENTER LINE	PROPOSED AERIAL FIBER CABLE PROPOSED BURIED FIBER (HDPE) 600THICK CABLE PROPOSED DIRECTIONAL BORE UE - UTILITY EASEMENT GAS LANE GAS VALVE MARKER PHONE PED FIBER VALVE TAP/VALVE WATER METER NOTE: BORE HOLE TO BE FILLED SAME DAY VAULT HOLE TO BE FILLED SAME DAY ALL HOLE TO BE TAMPED AND BODDED		ENGINEERED FOR 	BRAZOS COUNTY CLOUD LN BOOK END BND FAIRCREST DR MEREDITH LN TRANSPORT FIBER
	QUASAR, INC.	NO SCALE	SHEET 11 OF 17			

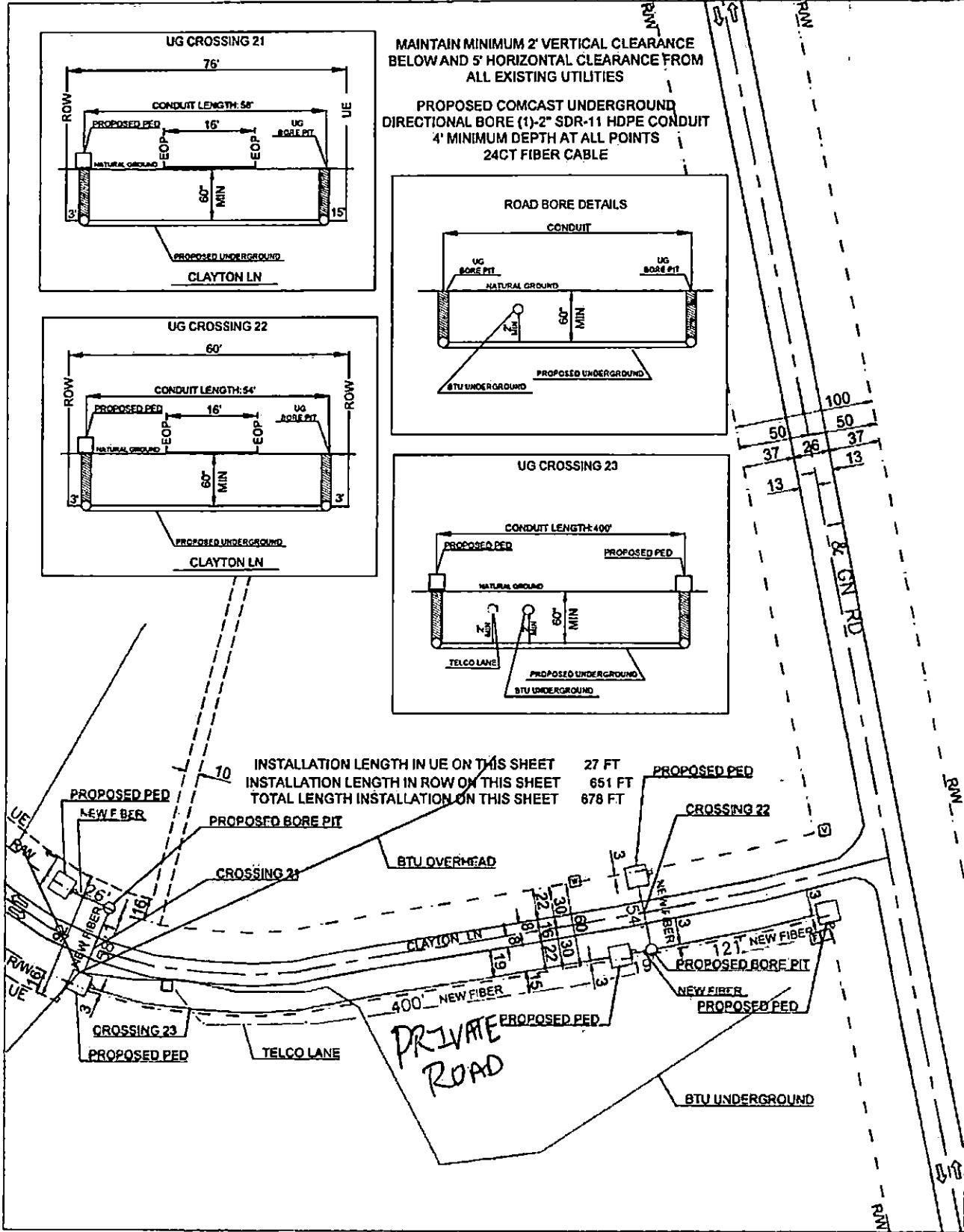

NO MATCH SHEET

NO MATCH SHEET

NO MATCH SHEET

PREPARED BY 	EXISTING POLE PROPOSED PEDESTAL BTU POLE PROPOSED BORE PIT WATER VALVE FIRE HYDRANT MANHOLE SEWER MANHOLE STORM PIPE FEATURE MARKER	RIGHT OF WAY LINE STORM SEWER LANE WATER LANE SANITARY & SEWER LANE BTU UNDERGROUND BTU OVERHEAD TELCO LANE PROPOSED PISER ROW - RIGHT OF WAY EOP - EDGE OF PAVEMENT BOC - BACK OF CURVE CL - CENTER LINE	PROPOSED AERIAL FIBER CABLE PROPOSED BURIED FIBER (7HOPE) EXISTING CABLE PROPOSED DIRECTIONAL BORE LE - UTILITY EASEMENT GAS LANE PHONE PED FIBER VALVE TAPPER WATER METER		ENGINEERED FOR 	BRAZOS COUNTY I & GN RD CLAYTON LN TRANSPORT FIBER
	NOTES: BORE HOLE TO BE FILLED SAME DAY VALVE HOLE TO BE FILLED SAME DAY ALL HOLE TO BE TAMPED AND SODDED		HO SCALE SHEET 13 OF 11			

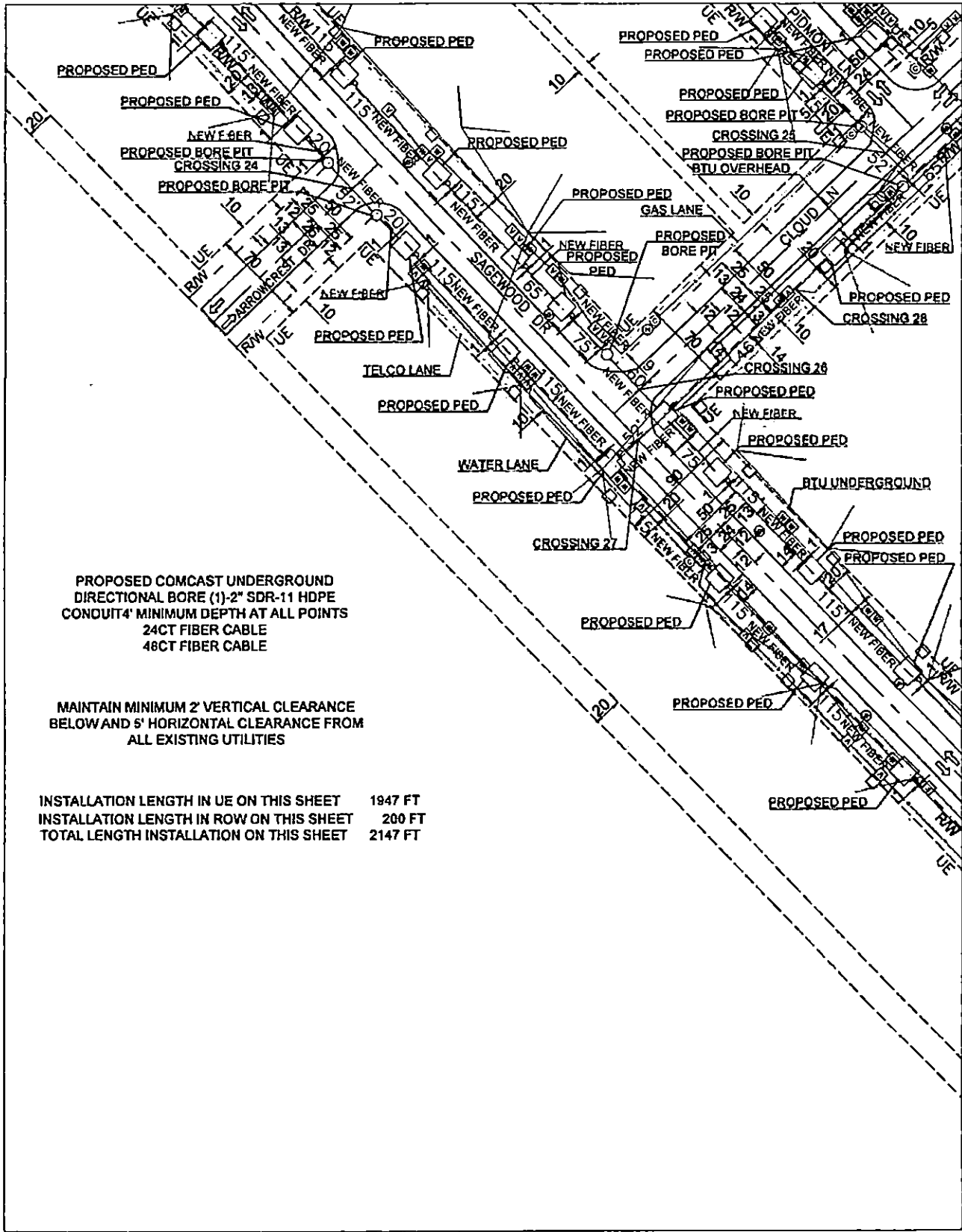

PROPOSED COMCAST UNDERGROUND
 DIRECTIONAL BORE (1)-2" SDR-11 HDPE
 CONDUIT 4' MINIMUM DEPTH AT ALL POINTS
 24CT FIBER CABLE
 48CT FIBER CABLE

MAINTAIN MINIMUM 2' VERTICAL CLEARANCE
 BELOW AND 5' HORIZONTAL CLEARANCE FROM
 ALL EXISTING UTILITIES

INSTALLATION LENGTH IN UE ON THIS SHEET 1947 FT
 INSTALLATION LENGTH IN ROW ON THIS SHEET 200 FT
 TOTAL LENGTH INSTALLATION ON THIS SHEET 2147 FT

NO MATCH SHEET

PREPARED BY 					ENGINEERED FOR 	BRAZOS COUNTY PIDMONT LN SAGEWOOD DR CLOUD LN TRANSPORT FIBER

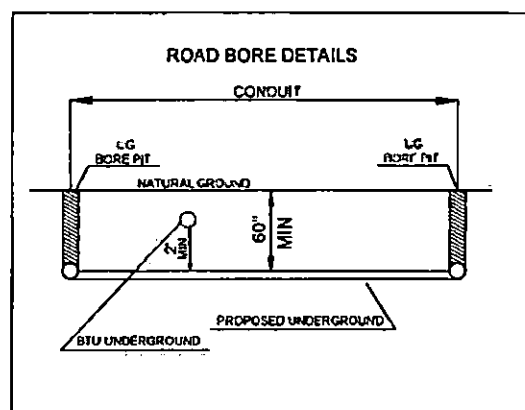
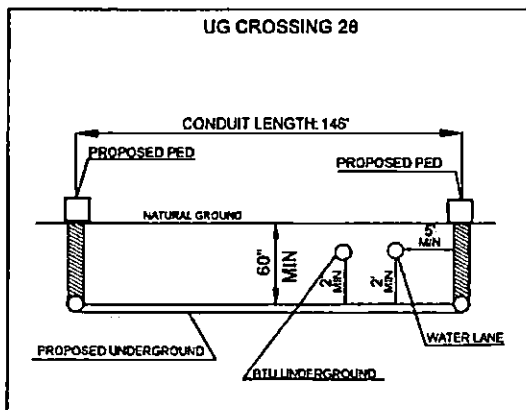
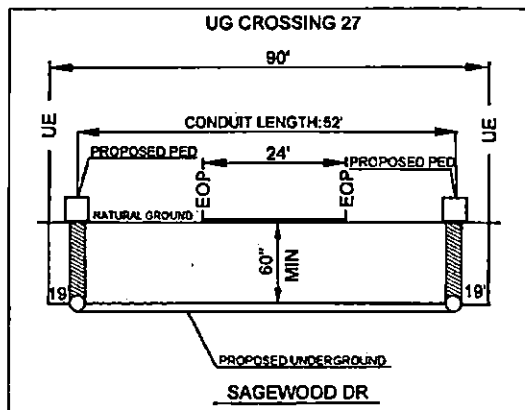
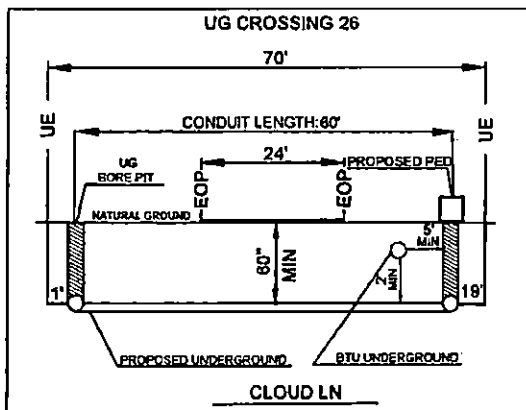
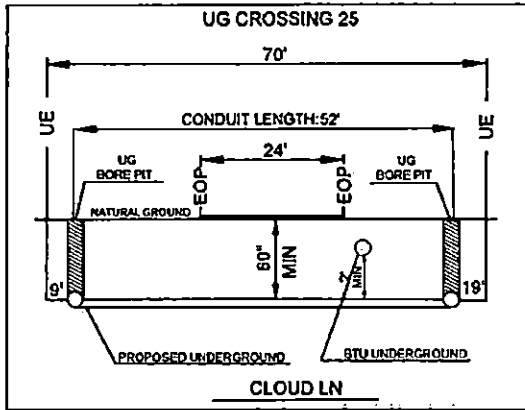
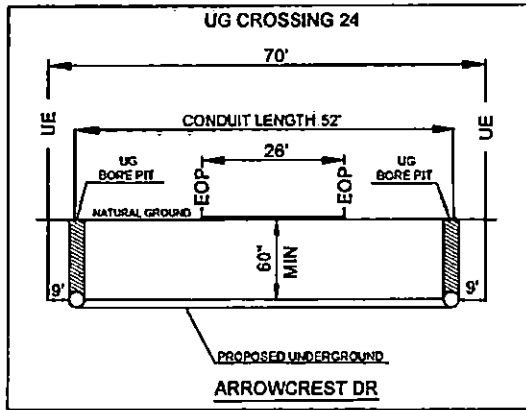

MATCH SHEET 10

MATCH SHEET 11

MATCH SHEET 13

MATCH SHEET 15

MAINTAIN MINIMUM 2' VERTICAL CLEARANCE
BELOW AND 5' HORIZONTAL CLEARANCE FROM
ALL EXISTING UTILITIES

PROPOSED COMCAST UNDERGROUND
DIRECTIONAL BORE (1)-2" SDR-11 HDPE CONDUIT
4' MINIMUM DEPTH AT ALL POINTS
24CT FIBER CABLE
48CT FIBER CABLE

INSTALLATION LENGTH IN UE ON THIS SHEET 2620 FT
INSTALLATION LENGTH IN ROW ON THIS SHEET 0 FT
TOTAL LENGTH INSTALLATION ON THIS SHEET 2620 FT

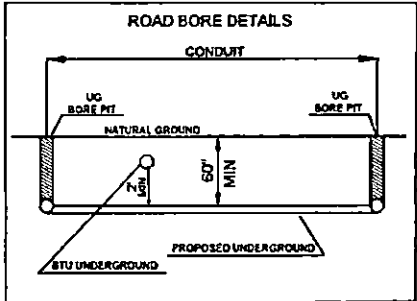

MATCH SHEET 13

MATCH SHEET 15

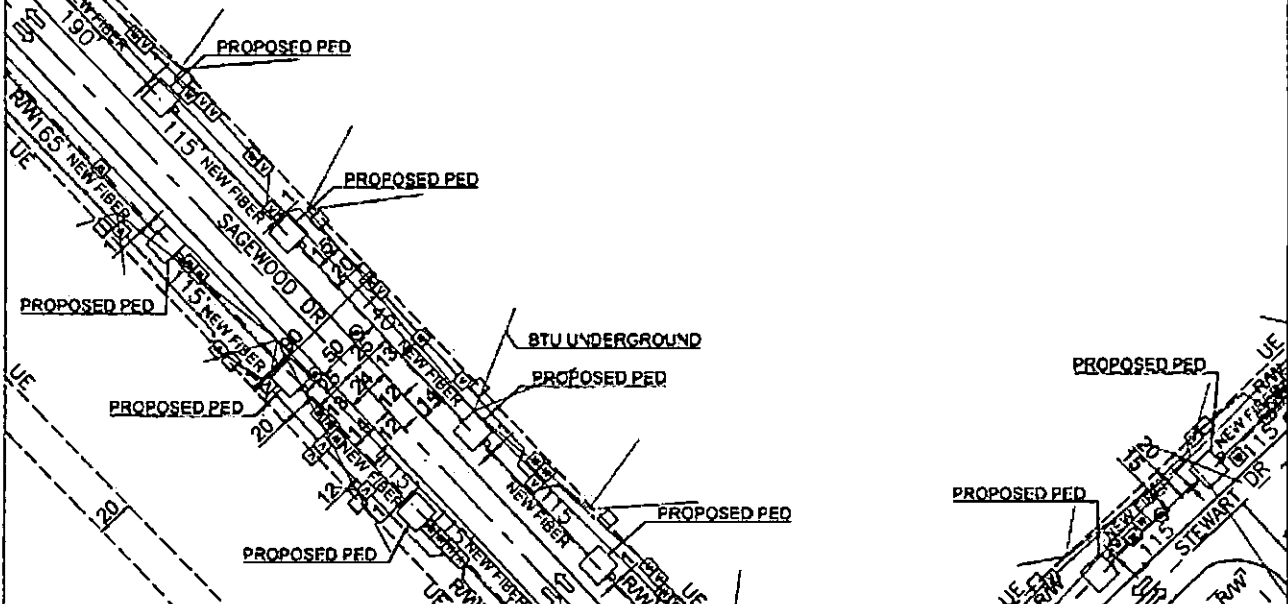

MATCH SHEET 16

MATCH SHEET 16

PREPARED BY 	EXISTING POLE PROPOSED PEDestal PROPOSED BORE PIT WATER VALVE FIRE HYDRANT MANHOLE SEWER MANHOLE STORM PIPE FEATURE MARKER	RIGHT OF WAY LINE STORM SEWER LANE WATER LANE SANITARY SEWER LANE BTU UNDERGROUND TELCO LANE PROPOSED FIBER RW - RIGHT OF WAY EOP - EDGE OF PAVEMENT BOC - BACK OF CURB CL - CENTER LINE	PROPOSED AERIAL FIBER CABLE PROPOSED BLURRED FIBER (7-HP) EXISTING CABLE PROPOSED DIRECTIONAL BORE UE - UTILITY EASEMENT GAS LANE PHONE PED FIBER VAULT MARKER WATER METER NOTES: BORE HOLE TO BE FILLED SAME DAY VAULT HOLE TO BE FILLED SAME DAY ALL HOLES TO BE STAMPED AND SIGNED		ENGINEERED FOR 	BRAZOS COUNTY MERCEDITH LN SAGEWOOD DR STEWART DR CLOUD LN TRANSPORT FIBER NO SCALE SHEET 14 OF 17
	QUASAR, INC.					

MATCH SHEET 11

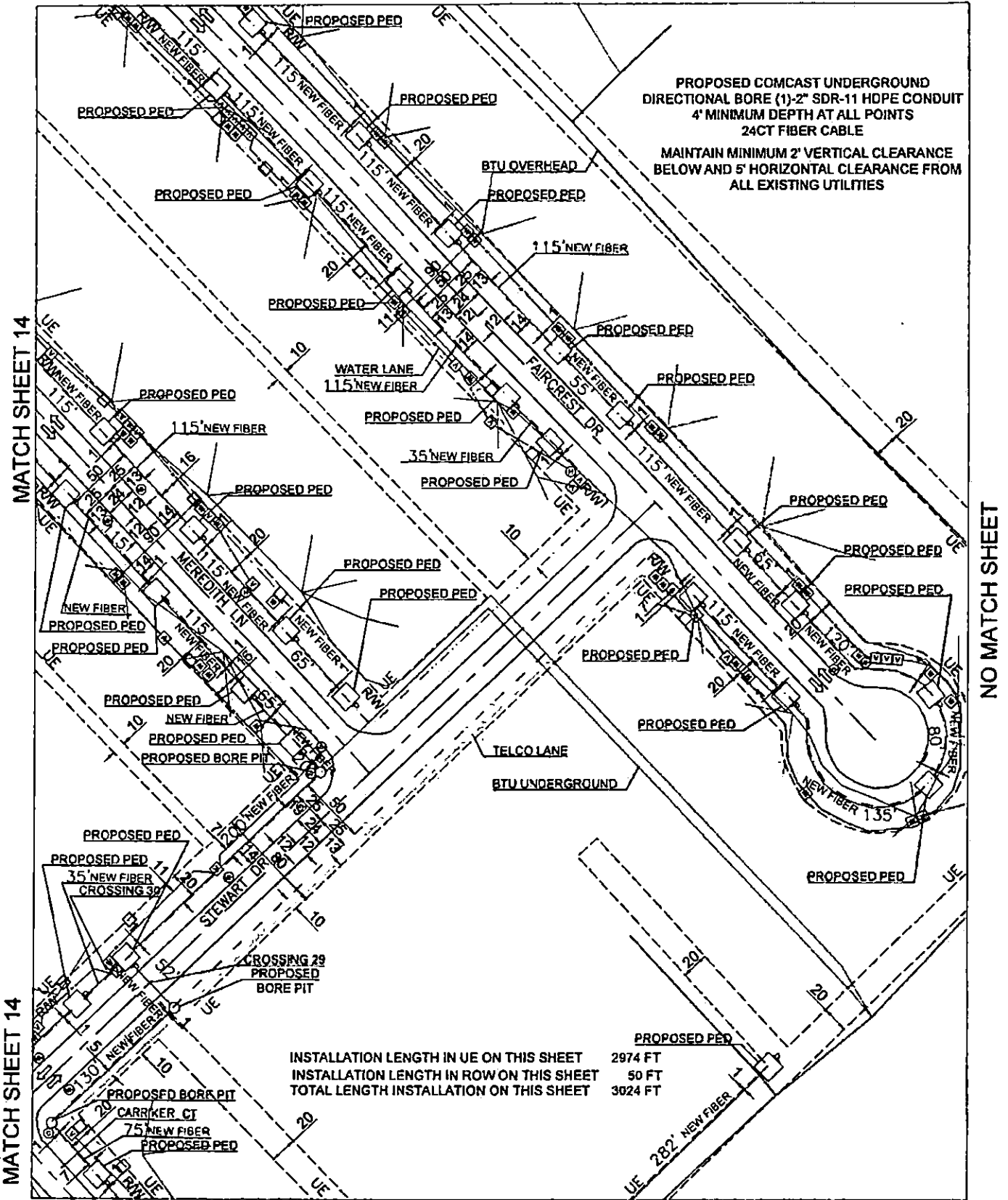

INSTALLATION LENGTH IN UE ON THIS SHEET 2974 FT
 INSTALLATION LENGTH IN ROW ON THIS SHEET 50 FT
 TOTAL LENGTH INSTALLATION ON THIS SHEET 3024 FT

MATCH SHEET 17

MATCH SHEET 17

PREPARED BY 	EXISTING POLE PROPOSED PEDESTAL PROPOSED BORE PIT WATER VALVE FIRE HYDRANT MANHOLE SEWER MANHOLE STORM PIPE FEATURE MARKER	RIGHT OF WAY LINE STORM SEWER LANE WATER LANE SANITARY SEWER LANE BTU UNDERGROUND BTU OVERHEAD TELCO LANE PROPOSED RESER 20' RIGHT OF WAY 10' EDGE OF PAVEMENT 50' BACK OF CURB CL - CENTER LINE	PROPOSED AERIAL FIBER CABLE PROPOSED BURIED FIBER (2) HOPE EXISTING CABLE PROPOSED DIRECTIONAL BORE UE - UTILITY EASEMENT GAS LANE PHONE LANE FIBER VALVE/MARKER WATER METER		ENGINEERED FOR 	BRAZOS COUNTY CARRIKER CT FAIRCREST DR STEWART DR MERIDITH LN TRANSPORT FIBER
	NOTES BORE HOLE TO BE FILLED SAME DAY VALVE HOLE TO BE FILLED SAME DAY ALL HOLE TO BE TAMPED AND ROCKED	NO SCALE SHEET 19 OF 17				

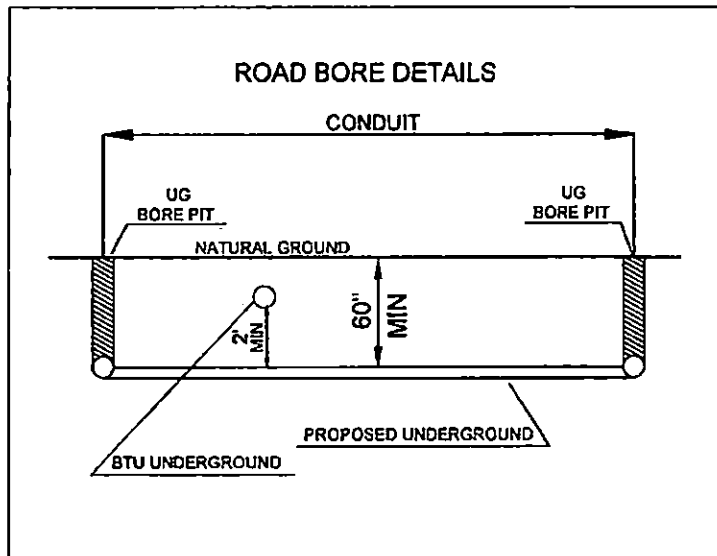
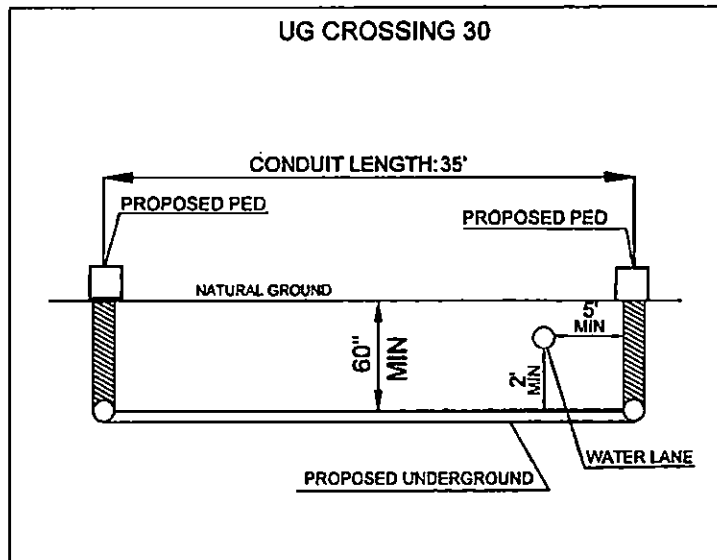
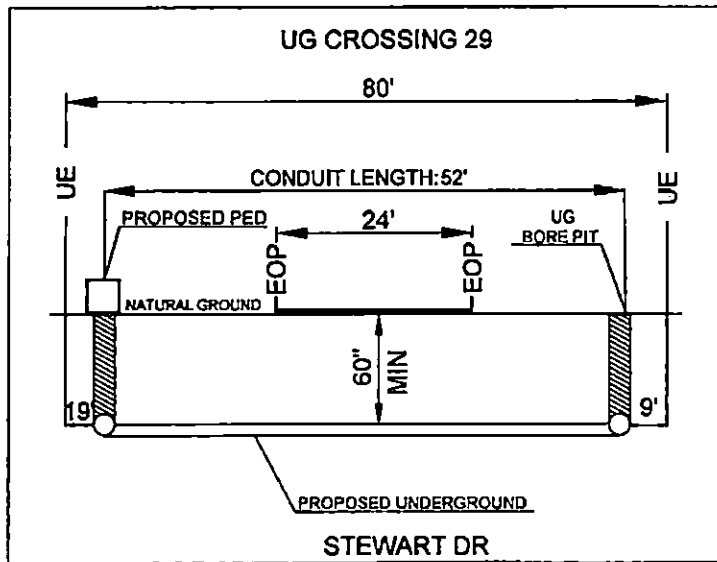

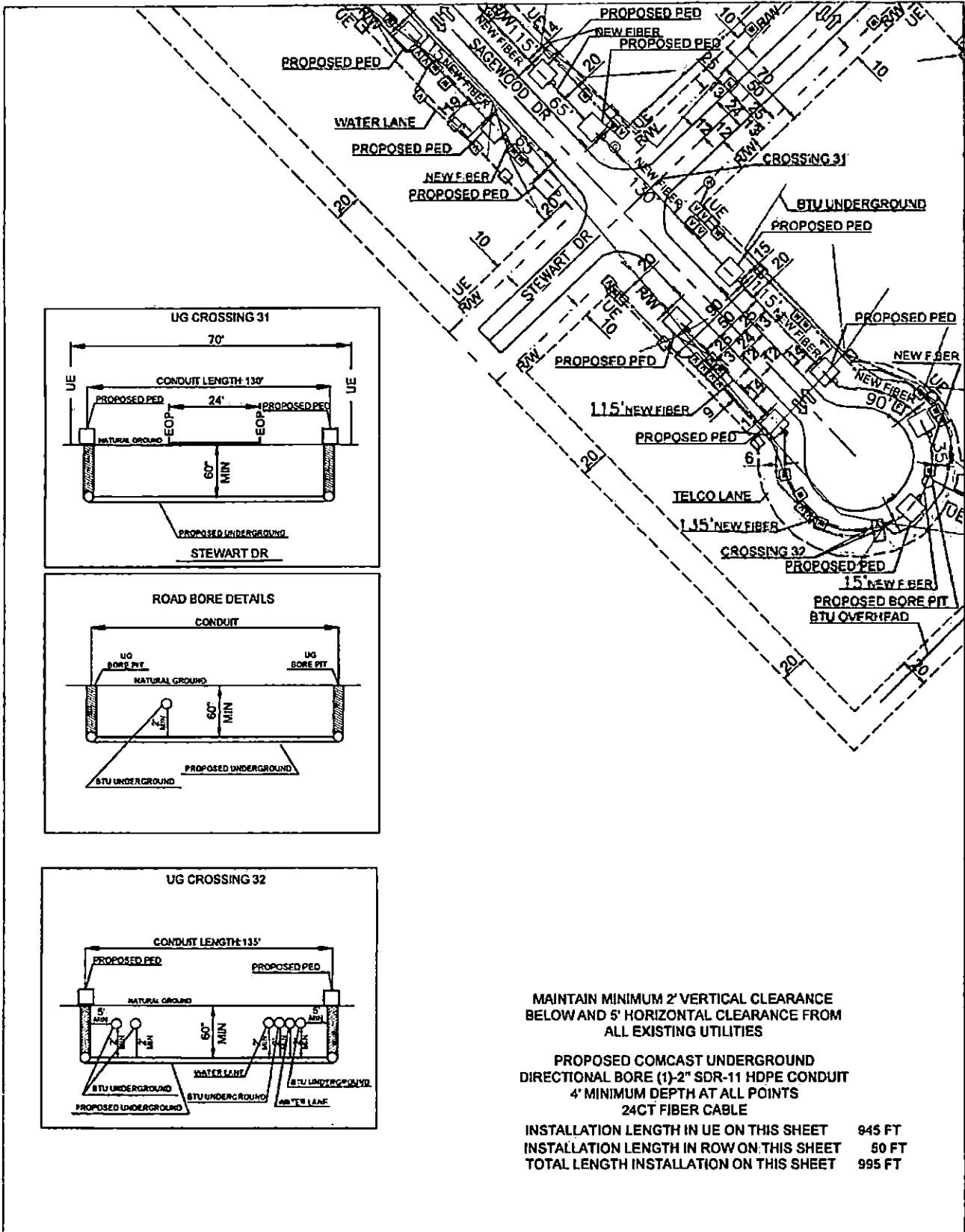

NO MATCH SHEET

MATCH SHEET 17

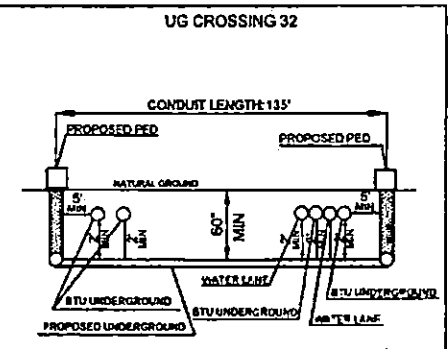
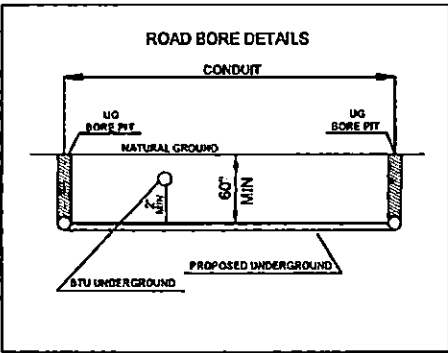
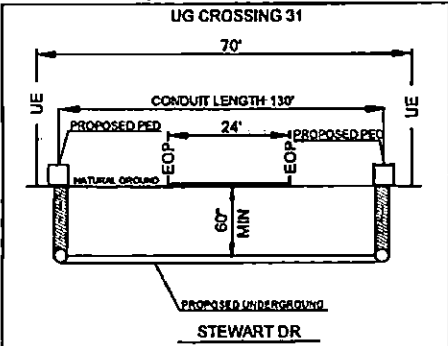

MAINTAIN MINIMUM 2' VERTICAL CLEARANCE BELOW AND 5' HORIZONTAL CLEARANCE FROM ALL EXISTING UTILITIES

PROPOSED COMCAST UNDERGROUND DIRECTIONAL BORE (1)-2" SDR-11 HDPE CONDUIT 4" MINIMUM DEPTH AT ALL POINTS 24CT FIBER CABLE

INSTALLATION LENGTH IN UE ON THIS SHEET 945 FT
 INSTALLATION LENGTH IN ROW ON THIS SHEET 60 FT
 TOTAL LENGTH INSTALLATION ON THIS SHEET 995 FT

NO MATCH SHEET

PREPARED BY: 	EXISTING POLE PROPOSED PEDESTAL 120" x 120" PROPOSED BORE PIT WATER VALVE FIRE HYDRANT MANHOLE SEWER MANHOLE STORM PIPE FEATURE MARKER	RIGHT OF WAY LINE STORM SEWER LANE WATER LANE SANITARY SEWER LANE BTU UNDERGROUND BTU OVERHEAD TELCO LANE PROPOSED FIBER RW - RIGHT OF WAY EOP - EDGE OF PAVEMENT BOP - BACK OF CURB CL - CENTER LINE	PROPOSED AERIAL FIBER CABLE PROPOSED BURIED FIBER (7-HP) (E) EXISTING CABLE PROPOSED DIRECTIONAL BORE UE - UTILITY EASEMENT GAS LANE PHONE PED FIBER VALVE/TANK/NER WATER METER		ENGINEERED FOR 	BRAZOS COUNTY SAGEWOOD DR STEWART DR TRANSPORT FIBER
	NOTES: BORE HOLE TO BE FILLED SAME DAY VALVE HOLE TO BE FILLED SAME DAY ALL HOLE TO BE TAMPED AND GODDED	NO SCALE SHEET 16 OF 17				

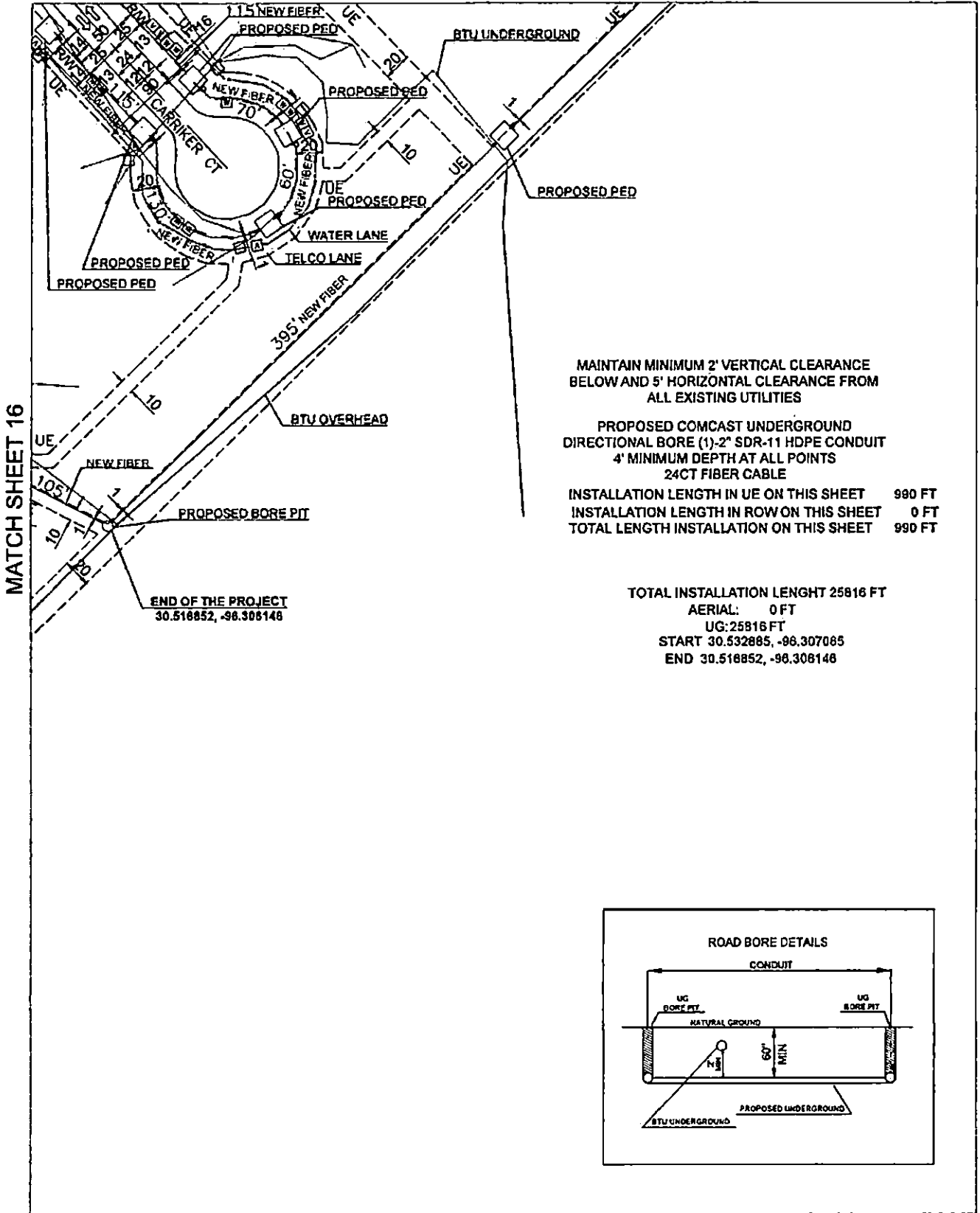

MATCH SHEET 16

NO MATCH SHEET

NO MATCH SHEET

<p>PREPARED BY:</p> <p>QUASAR, INC.</p>	<ul style="list-style-type: none"> EXISTING POLE PROPOSED PEDESTAL PROPOSED BORE PIT WATER VALVE FIRE HYDRANT MANHOLE COVER MANHOLE STORM PIPE FEATURE MARKER RIGHT OF WAY LINE STORM SEWER LANE WATER LANE SANITARY SEWER LANE BTU UNDERGROUND BTU OVERHEAD TELCO LANE PROPOSED RISER RAY - RIGHT OF WAY ROP - EDGE OF PAVEMENT ROC - BACK OF CURB CL - CENTER LINE 	<ul style="list-style-type: none"> PROPOSED AERIAL FIBER CABLE PROPOSED BURIED FIBER (7-HPPE) EXISTING CABLE PROPOSED DIRECTIONAL BORE UE - UTILITY EASEMENT GAS LANE PHONE PED FIBER VALVE MARKER WATER METER NOTE: BORE HOLE TO BE FILLED SAME DAY VANT HOLE TO BE FILLED SAME DAY ALL HOLE TO BE TAMPED AND BODDED 		<p>ENGINEERED FOR</p> <p>COMCAST</p>	<p>BRAZOS COUNTY</p> <p>CARRIKER CT</p> <p>TRANSPORT FIBER</p> <p>NO SCALE</p> <p>SHEET 17 OF 17</p>
---	---	---	--	--------------------------------------	--

**BRAZOS COUNTY ROADWAY SAFETY AND ROAD
PRESERVATION STANDARDS FOR WORK CONDUCTED IN
BRAZOS COUNTY RIGHTS OF WAY**

A. General Requirements

1. Adequate drainage shall be maintained in ditches at all times.
2. Permittee will use best management practices ("BMP") (EPA and TCEQ both provide lists of examples of BMPs) to minimize erosion and sedimentation resulting from the proposed installation.
3. The permittee shall take precautions to avoid damage to property. All County Right of Way and property shall be restored to its original condition, as far as practical, in the opinion of the County Engineer or appointed representative.
4. The construction and maintenance of such utility shall not interfere with the property or rights of a prior occupant.
5. Permittee shall not interfere with other utilities located in the right of way. In the event damages occur, permittee will be liable to the County or other utilities running through the right of way.
6. County Engineer shall determine whether or not permittee's plans shall inconvenience the public. If it is determined that inconvenience to the public exists, then the County Engineer will decide whether such project will be allowed or if an alternative exists so as not to inconvenience the public.

B. Safety Requirements

1. Proper traffic control measures must be put in place prior to beginning work and remain in place during the duration of the job. All traffic control measures must follow the Texas Manual of Uniform Traffic Control Devices (TMUTCD), See Traffic Control Requirements below.
2. During construction, all safety regulations of the Texas Department of Transportation shall be observed.
3. Permittee must take such precautions and measures, including placing and displaying safety devices, as may be necessary, in order to safely conduct the public through the project area. Company shall provide flagmen, signs, signals or devices necessary to provide complete safety to the public.
4. Adequate provisions must be made to cause minimum inconveniences to traffic and adjacent property owners.
5. No cable, conduit and/or pole line shall be laid, constructed, maintained and/or repaired so as to constitute a danger or hazard of any kind to persons or vehicles using such road. Any poles placed in the Right of Way for future installation shall be placed at the back of the Right of Way. Exceptions may be approved by the County Engineer.

C. Traffic Control Plan

1. A traffic control plan, pursuant to the TMUTCD or Engineered Traffic Control Plan must be provided for the following:
 - a. Any construction (i.e. pit, excavation, hole) left open over night, requires specific nighttime traffic control measures pursuant to the TMUTCD;
 - b. If construction is within ten (10) feet of the roadway; or
 - c. Any work performed in the road right-of-way;

2. Plan must be attached to the permit and kept at the job site any time work is being performed.
3. Plan must set forth the time of completion for the job.

D. Design Standards

1. All overhead installations shall conform to clearance standards of the Texas Department of Transportation and the pole be placed in the designated area for power specified as set forth in the *Texas Utilities Code, Section 181.045*.
2. All pole installation (including lighting) shall be placed at the backside of the Right of Way to ensure safety to the public. Any pole placed in violation of this requirement will be required to be moved to the appropriate location at the company's expense. Exceptions may be approved by the County Engineer.
3. All underground installations shall (these are minimum depths – utility may place deeper):
 - a. be placed at a minimum depth of forty-eight (48) inches below the top of the pavement;
 - b. be at least thirty-six (36) inches below ditch flow line when installation is within the area measured from top of bank to top of bank;
 - c. be at least forty-eight (48) inches below ditch flow line if low pressure gas or petroleum lines. For high pressure gas and petroleum lines, see High Pressure Pipelines requirements listed below;
 - d. not be closer than ten (10) feet from the edge of pavement. Exceptions may apply in rights of way of less than 60'.
4. Water Lines: All water lines must be a minimum 36-inches below the ditch flow line and cased. Waterlines shall be cased if crossing under the roadway.
5. Utilities in all new developments that have 60 feet or greater of right of way shall be installed within designated locations based upon the type of utility. The locations shall be as follows: (measured from back of right-of-way).
 - Power – 0-2 feet, nominally 1'
 - Phone – 2-4 feet, nominally 3'
 - Gas – 4-6 feet, nominally 5'
 - Cable – 6-8 feet, nominally 7'
6. Utilities with less than 60 feet right-of-way in all new developments shall install the utility in a similar manner as referenced in No. 3 above, however, the County Engineer or its designated representative will provide final approval of each utility location.
7. The length of any trench to be opened in advance of the pipe, conduit or ducts may not be longer than 400' if left open over night or unattended.
8. Crossings under a county road shall:
 - a. be bored or jacked. **ABSOLUTELY NO OPEN CUTS WITHIN COUNTY ROAD PAVEMENT;**
 - b. be pressure grouted for the full length of the crossing *if* the annular space between pipe and casing and soil exceeds one (1) inch. Brazos County must be given 24 hours notice of pressure grouting operations and have the opportunity to have an inspector on site to observe pressure grouting operations;
 - c. TxDOT Standard Specification Item 476 shall be followed for all boring, jacking, tunneling and joints.
9. Bore Pits
 - a. no pits shall remain open longer than 2 days;

- b. all pits shall have proper traffic control measures in place. See Traffic Control Plan listed above.
 - c. pits shall NOT be located within ten (10) feet from the edge of pavement without prior approval from the County Engineer or his representative;
 - d. when pits are to remain open for more than 8 hours, due diligence will be used in protecting the spoil pile to prevent drainage problems;
 - e. based upon soil conditions, the County Engineer or his representative may require shoring to protect pavement integrity;
 - f. based upon soil conditions, the County Engineer or his representative may require pits be placed further from the edge of road.
10. Any installation within ten (10) feet of edge of pavement shall meet the following:
- a. location must be approved by the County Engineer or his representative
 - b. backfilled with cement stabilized material.
 - c. based upon soil conditions, the County Engineer or his representative may require shoring to protect pavement integrity.
 - d. All excess water and mud shall be removed from the trench prior to backfilling. Any backfill placed during a rainy period or at other times where excess water cannot be prevented from entering the trench will be considered TEMPORARY and shall be replaced with PERMANENT cement stabilized material as soon as weather permits;
 - e. All disturbed base and pavement materials shall be removed and restored to the satisfaction of the County Engineer or his representatives.
 - f. No side or lateral tamping to fill voids under the base and pavement materials is allowed.
11. Company must be careful to not jeopardize the slope or integrity of the shoulder of the road. In the event Company damages the slope, shoulder or any other portion of the right-of-way, Company will be responsible for repairing the damage and replacing the right-of-way to the condition it was prior to commencing construction.
12. Operation of construction and/or maintenance equipment on the traveled surface of any improved County road will not be permitted, except in an instance whereby the laying, construction, maintenance and/or repair of cables, conduits and/or pole lines cannot be accomplished by any other method and in this event all such equipment shall be of the rubber tire variety. Appropriate traffic control shall be provided meeting TMUTCD requirements.
13. In the event said construction and/or maintenance and/or repair requires Company to remove, cut or jeopardize any section of the road (asphalt, cement, road base, etc), Company will be required to provide a performance bond or letter of credit securing necessary repairs. Said bond amount will be determined by the County Engineer.
14. The applicant shall submit a letter of "No Objection" from the Army Corps of Engineers for all designated wetlands and environmentally sensitive lands.

E. Emergency work

- 1. In the event Company is required to perform emergency services, that requires excavation in a County Right of Way, and unable to notify the County Engineer prior to conducting emergency repairs, Company shall notify County Engineer within 24 hours of beginning construction/repairs. This will allow the County Engineer and Road & Bridge Office an opportunity to inspect the site to ensure the integrity of the County Right of Way and traffic safety controls used.

F. Repairs to existing facilities

1. Maintenance and/or repair to existing cables, conduits, and/or pole lines which require disturbance of the soil, shall not be performed until plans describing such maintenance and/or repair have been approved by the County Engineer or designated representative and a permit has been obtained.

G. Relocation of utilities:

1. When and if the County Engineer determines that it is necessary for the construction, repair, improvement, alteration or relocation of all or any portion of said road, any or all poles, wires, pipes, cables or other facilities and appurtenances authorized hereunder, shall be removed from said road, or reset or relocated thereon, as required by the County Engineer within a reasonable time as determined by the County Engineer and Utility Company, and at the expense of the Utility Company.

H. High Pressure Pipelines

1. All utility Permits for high pressure pipelines (generally 60 PSI or greater), whether pertaining to controlled access or non-controlled access installations, should contain the following additional information in the description of the permit.
 - diameter
 - wall thickness
 - material specification
 - minimum yield strength
 - maximum operation pressure of the pipeline
2. With the exception of the maximum operation pressure of the pipeline, this information is to be supplied for both the carrier pipe and the casing.
3. Assurance must also be given that the installation material and design meet the minimum Federal Safety Standards for Liquid and Gas Pipe Lines. Assurance must be provided on company letterhead and signed by an authorized representative of the company.

4. Petroleum Pipelines:

<u>Type of Pipeline</u>	<u>Depth (below deepest ditch grade)</u>	<u>Special Requirements</u>
Encased Pipe	Less than 10'	Must be covered with concrete pad at least 36" deep
Encased Pipe	Greater than 10'	No concrete pad required
Non-Cased Pipe	Less than 10'	Must be covered with concrete pad at least 48" deep
Non-Cased Pipe	Greater than 10'	No concrete pad required

The Concrete pad shall be minimum of 3" thick and width shall be pipe diameter plus 18" minimum.

5. Under no circumstances will a pipeline be installed parallel to a County Road within the Right-of-Way. Transmission lines have been determined to be petroleum pipelines (which includes natural gas lines) and shall not be parallel to a County Road.
6. Natural Gas Distribution is a line that serves the final customer.

DISCLAIMER: The use of this standard is governed by the Texas Engineering Practice Act. No warranty of any kind is made by TCEQ for any purpose whatsoever. TCEQ assumes no responsibility for the construction of any project or for any consequences that may result from the use of this standard.

DATE: _____
 FILE: _____

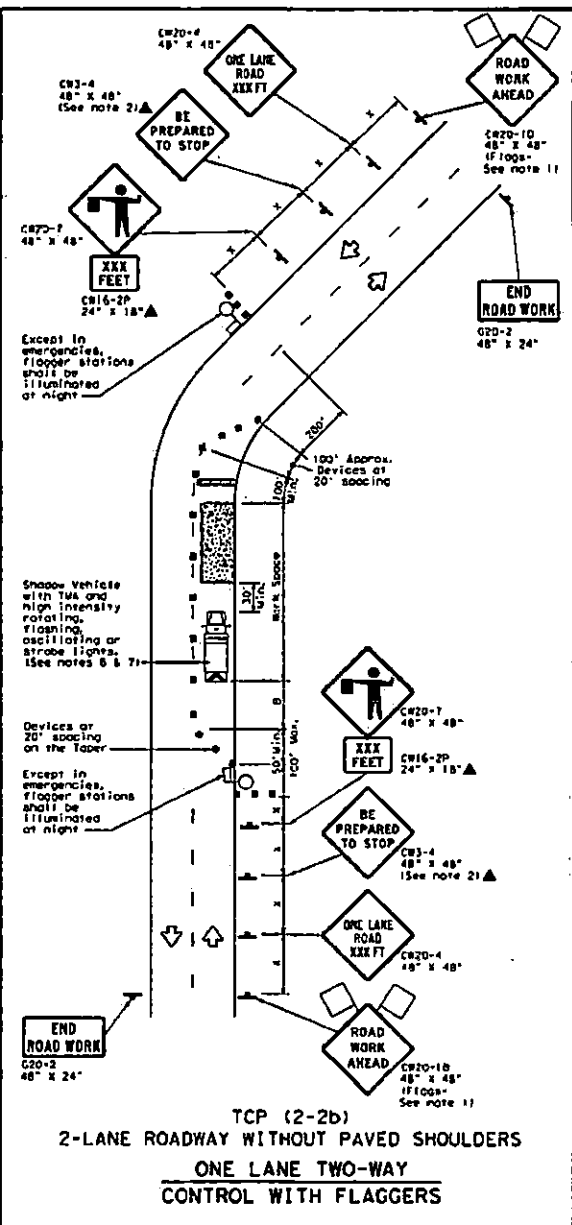
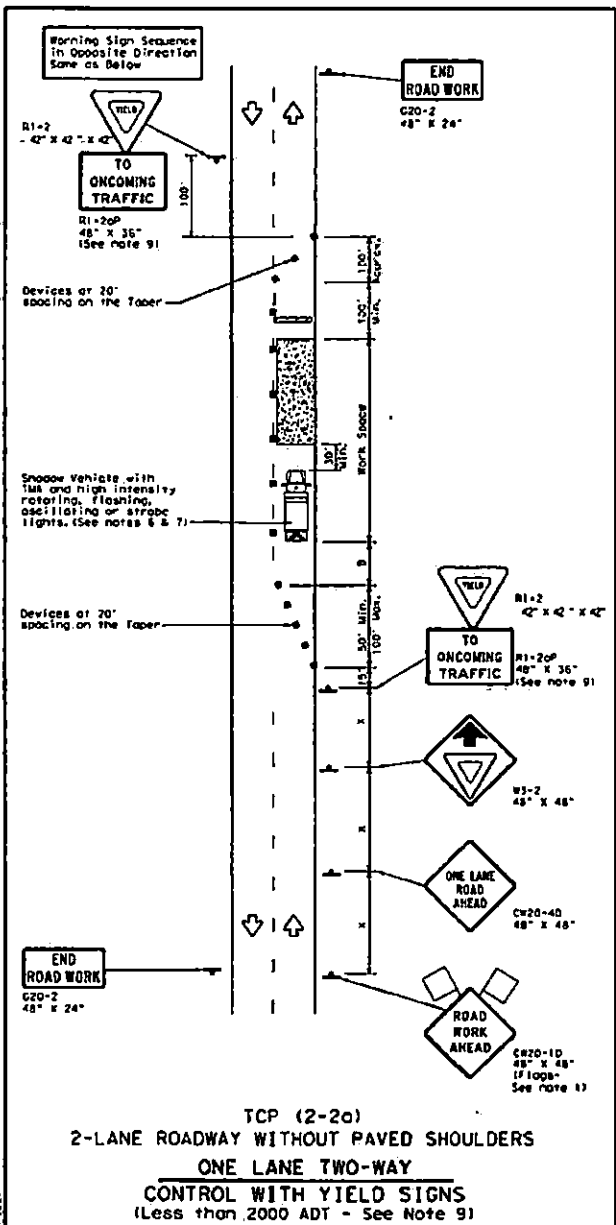

LEGEND

	Type 3 Barricade		Channelizing Devices
	Heavy Work Vehicle		Truck Mounted Attenuator (TMA)
	Trailer Mounted Flashing Arrow Board		Portable Changeable Message Sign (PCMS)
	Sign		Traffic Flow
	Flag		Flagger

Posted Speed M	Formula	Minimum Desirable Taper Lengths in Feet			Suggested Maximum Spacing of Channelizing Devices		Minimum Sign Spacing in Feet	Suggested Longitudinal Buffer Space in Feet	Stopping Sight Distance in Feet
		10' Offset	11' Offset	12' Offset	On a Taper	On a Tonnage			
30	L = $\frac{S^2}{60}$	150'	165'	180'	30'	60'	120'	90'	200'
35		205'	225'	245'	35'	70'	160'	120'	250'
40	L = 45	265'	295'	320'	40'	80'	240'	155'	305'
45		450'	495'	540'	45'	90'	320'	195'	360'
50	L = 85	500'	550'	600'	50'	100'	400'	240'	425'
55		550'	605'	660'	55'	110'	500'	295'	495'
60	L = 125	600'	660'	720'	60'	120'	600'	350'	570'
65		650'	715'	780'	65'	130'	700'	410'	645'
70	L = 165	700'	770'	840'	70'	140'	800'	475'	730'
75		750'	825'	900'	75'	150'	900'	540'	820'

For Conventional Roads Only
 M = Taper Lengths have been rounded off.
 L = Length of Taper (F) = Width of Offset (F) S = Posted Speed (MPH)

TYPICAL USAGE				
MOBILE	SHORT DURATION	SHORT TERM STATIONARY	INTERMEDIATE TERM STATIONARY	LONG TERM STATIONARY
	✓	✓	✓	✓

GENERAL NOTES

- Flags attached to signs where shown, are REQUIRED.
- All traffic control devices illustrated are REQUIRED, except those denoted with the triangle symbol may be omitted when stated elsewhere in the plans, or for routine maintenance work, when approved by the Engineer.
- The CW3-4 "BE PREPARED TO STOP" sign may be installed after the CW20-4 "ONE LANE ROAD XXX FT" sign, but proper sign spacing shall be maintained.
- Flaggers should use two-way radios or other methods of communication to control traffic.
- Length of work space should be based on the ability of flaggers to communicate.
- A Shadow Vehicle with TMA should be used anytime it can be positioned 30 to 100 feet in advance of the area of crew exposure without adversely affecting the performance or quality of the work. If workers are no longer present but road or work conditions require the traffic control to remain in place, Type 3 Barricades or other channelizing devices may be substituted for the Shadow Vehicle and TMA.
- Additional Shadow Vehicles with TMA may be positioned off the paved surface, next to those shown in order to protect a wider work space.

TCP (2-2a)

- The R1-2 "FIELD" sign traffic control may be used on projects with approaches that have adequate sight distance. For projects in urban areas, work space should be no longer than one half city block. In rural areas, runways with less than 2,000 ADT, work space should be no longer than 400 feet.
- Length of work space should be based on the ability of flaggers to communicate.
- The R1-20P "FIELD TO ONCOMING TRAFFIC" sign shall be placed on a support at a 1 foot minimum mounting height.

TCP (2-2b)

- Channelizing devices on the center line may be omitted when a pilot car is leading traffic and approved by the Engineer.
- If the work space is located near a horizontal or vertical curve, the buffer distances should be increased in order to maintain stopping sight distance to the flagger and a queue of stopped vehicles. (See table above).
- Flaggers should use 24" STOP/SLOW paddles to control traffic; flags should be limited to emergency situations.

Notes:
 The contractor must notify the precinct at least 48 hours before a lane closure.
 No lanes shall be closed during the hours of 7:00 AM to 9:00 AM and 4:00 PM to 6:00 PM Monday through Friday.

Texas Department of Transportation
 Traffic Operations Division Standard

TRAFFIC CONTROL PLAN
ONE-LANE TWO-WAY
TRAFFIC CONTROL
TCP (2-2)-18

FILE#	PROJECT	DATE	REV	BY	CHK
102-7-18-001	December 1985	08/11	01	JMS	WJMS
8-85	2-87	2-12			
4-86	2-18				

1154

ACCEPTANCE OF NOTIFICATION

Brazos County offers no objection to the proposed location of the utility in the County right of way as shown by accompanying drawings and notice dated June 4, 2026 except as noted below:

EXCEPTIONS: **Brazos County considers Book End Bend and Clayton Lane as PRIVATE, therefore NO permit will be issued for these roadway. Conduits and appurtenances within Meadowcreek Subdivision MUST be placed within the platted Public Utility Easements (PUE)**

FOR  _____
Brazos County Engineer



**BRAZOS COUNTY
BRYAN, TEXAS**

DEPARTMENT: Road and Bridge NUMBER: CC-2026-Comcast-Silver Hill-Bush-Leonard

DATE OF COURT MEETING: 6/23/2026

ITEM: Consider and take action on the Comcast utility permit to install 2-inch conduit by directional bore within the right-of-way of following County Roads. Sites are located in Precinct 4.

- a. Silver Hill Road – 6,227 feet in ROW and 8 crossings
- b. Bush Lane – 639 feet in ROW and 1 crossing
- c. Leonard Road – 2,041 feet in ROW and 2 crossings

TO: Commissioners Court

FROM: Joe Salvato

DATE: 06/02/2026

FISCAL IMPACT: False

BUDGETED: False

DOLLAR AMOUNT: \$0.00

Brazos County considers Marcia Lane as PRIVATE, therefore NO permit will be issued for this roadway. Conduits and appurtenances MUST be placed within the platted Public Utility Easement (PUE), where applicable

Department requesting agenda item: Road and Bridge

Department impacted by agenda item: Road and Bridge

NOTES/EXCEPTIONS: Brief explanation of agenda item and if in current year budget: Permit allows Comcast to install fiber optic conduit and construct road bores within right-of-ways of Silver Hill Road - 6,227 feet with 8 crossings; Bush Lane - 639 feet with 1 crossing and Leonard Road - 2,041 feet with 2 crossings

Brazos County has NO financial responsibility in project.

Consequences for failing to approve agenda item: Less customer choice for internet

Deadline for agenda item approval: As soon as possible

Site of work being performed: Precinct 4 - Silver Hill Road, Bush Lane and Leonard Road

ATTACHMENTS:

File Name

[Utility Permit-Comcast-Silver Hill-Bush-Leonard.pdf](#)

Description

Utility Permit-Comcast-Silver Hill-Bush-Leonard

Type

Backup Material

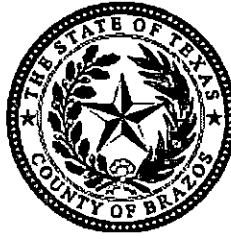

**BRAZOS COUNTY
BRYAN, TEXAS**

DEPARTMENT: Road and Bridge NUMBER: CC-2026-Comcast-Silver Hill-Bush-Leonard

DATE OF COURT MEETING: 6/23/2026

ITEM: Consider and take action on the Comcast utility permit to install 2-inch conduit by directional bore within the right-of-way of following County Roads. Sites are located in Precinct 4.

- a. Silver Hill Road – 6,227 feet in ROW and 8 crossings
- b. Bush Lane – 639 feet in ROW and 1 crossing
- c. Leonard Road – 2,041 feet in ROW and 2 crossings

TO: Commissioners Court

FROM: Joe Salvato

DATE: 06/02/2026

FISCAL IMPACT: False

BUDGETED: False

DOLLAR AMOUNT: \$0.00

Brazos County considers Marcia Lane as PRIVATE, therefore NO permit will be issued for this roadway. Conduits and appurtenances MUST be placed within the platted Public Utility Easement (PUE), where applicable
Department requesting agenda item: Road and Bridge
Department impacted by agenda item: Road and Bridge
Brief explanation of agenda item and if in current year budget: Permit allows Comcast to install fiber optic conduit and construct road bores within right-of-ways of Silver Hill Road - 6,227 feet with 8 crossings; Bush Lane - 639 feet with 1 crossing and Leonard Road - 2,041 feet with 2 crossings
Brazos County has NO financial responsibility in project.
Consequences for failing to approve agenda item: Less customer choice for internet
Deadline for agenda item approval: As soon as possible
Site of work being performed: Precinct 4 - Silver Hill Road, Bush Lane and Leonard Road

ATTACHMENTS:

<u>File Name</u>	<u>Description</u>	<u>Type</u>
Utility_Permit-Comcast-Silver_Hill-Bush-Leonard.pdf	Utility Permit-Comcast-Silver Hill-Bush-Leonard	Backup Material

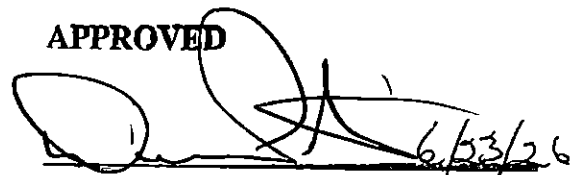
APPROVED

Duane Peters Date 6/23/26
County Judge

**NOTIFICATION OF PROPOSED INSTALLATION AND/OR REPAIRS
OF TELEPHONE FACILITIES AND DESIGNATING
PLACEMENT OF UTILITY IN COUNTY RIGHT OF WAY
TO: THE COUNTY ENGINEER OF BRAZOS COUNTY, TEXAS**

Comes now Comcast of Houston, LLC [company name], hereinafter referred to as "Company" a Texas [state] Corporation, with authority to transact business in Texas, acting by and through its duly authorized representative, and hereby notifies the County Engineer of its intent to lay, construct, maintain, repair and/or operate a telephone facility under, over, across and/or along certain County Roads as shown on drawings and diagrams attached hereto and said location described as follows:

Comcast proposes installing by directional bore a single 2-inch SDR-11 HDPE conduit with associated pedestals within the right-of-way of the following County Roads:

Silver Hill Road – 6,227 feet in ROW and 8 crossings (1,234' in PUE)

Bush Lane – 639 feet in ROW and 1 crossing (701' in PUE)

Leonard Road – 2,041 feet in ROW and 2 crossings (1,621' in PUE)

Project includes the installation of 24/48/96-count fiber optic cable at a minimum depth of 4-feet at all points and a minimum of 5-feet under roadways

The location and description of the proposed installation and appurtenances must be fully shown on detailed drawings attached to this Notification.

The Company shall commence actual construction/work in good faith within 60 days from the date of said permit and shall complete said construction /work within 10 working days. (COMPANY MUST FILL IN). If such construction is not begun by the 60th day, Company will be required to provide a new notice.

Company declares that prior to filing this application, it has ascertained the location of all existing utilities, both aerial and underground, and the filing of this application is prima facie evidence that the proposed installation will not conflict with any existing utility.

A copy of this notice shall be kept at the job site any time work is being performed.

In the event of deviation from this notice, the Brazos County Engineer's Office or its designated representative will be notified as soon as practicable.

Approval of County Engineer's Office may take as long as two weeks after complete application is received.

Failure to notify the County Engineer's Office within 24 hours of beginning construction shall constitute grounds for job shutdown.

By signing below, I certify that I am authorized to represent the Company listed below, and that the Company agrees to the conditions/provisions included in this notification.

Comcast of Houston LLC

Company Name

Justin Valentine

By:

Signature

Planning & Design Manager

Title

8590 West Tidwell Rd, Houston, Tx, 77040

Address

Phone Number 281-889-5413

Email:

dwenta@quasar.us

Justin_Valentine@comcast.com

shaneitra_jones@comcast.com

Ryan_Hawkins@comcast.com

kpiszczyk@quasar.us

ACCEPTANCE OF NOTIFICATION

Brazos County offers no objection to the proposed location of the utility in the County right of way as shown by accompanying drawings and notice dated June 3, 2026 except as noted below:

EXCEPTIONS: Brazos County considers Marcia Lane as PRIVATE, therefore NO permit will be issued for this roadway. Conduits MUST be placed within the platted Public Utility Easements (PUE), where applicable.

For  _____
Brazos County Engineer

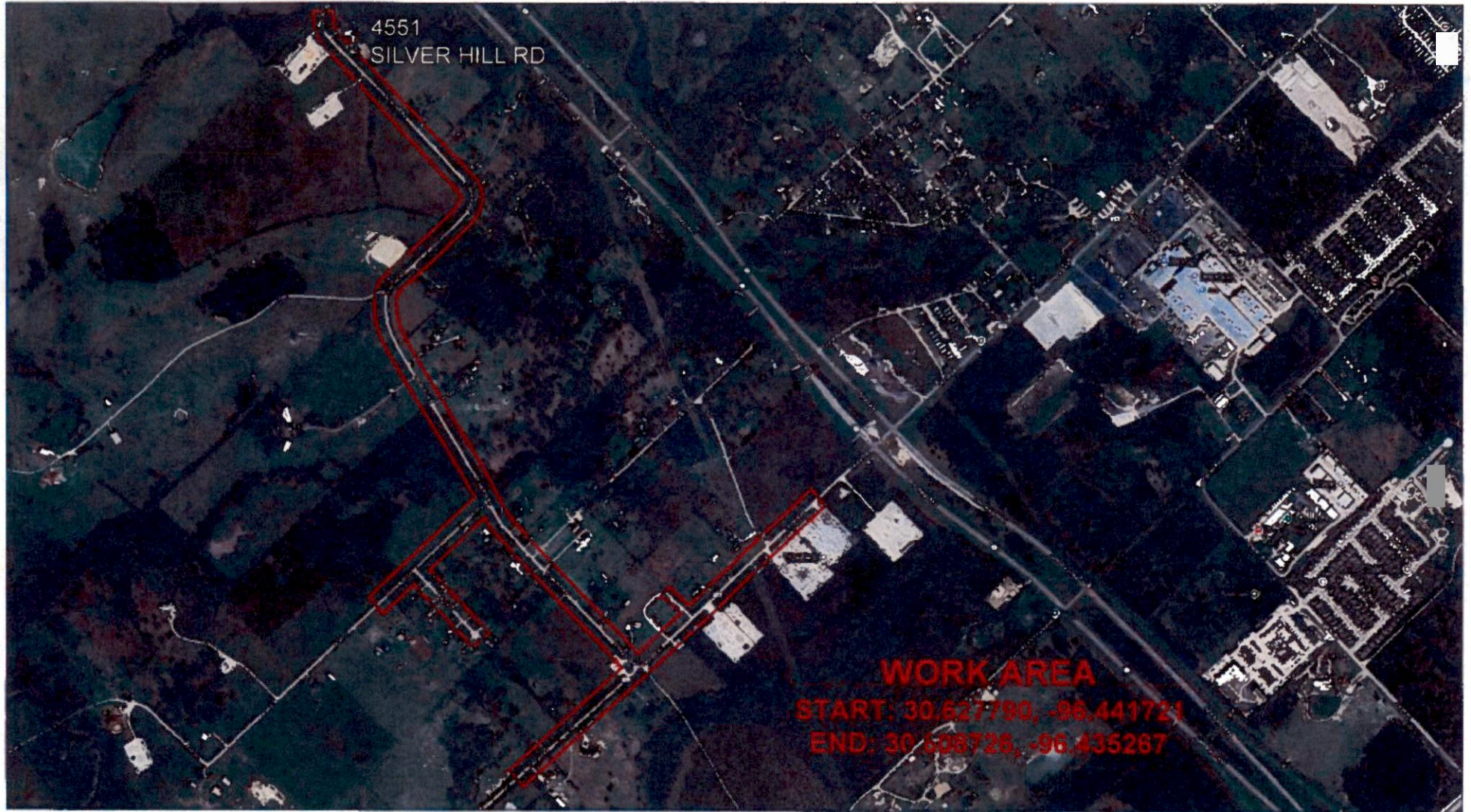

PREPARED BY:



COMCAST IS BORING AND INSTALLING NEW CONDUIT
 WITHIN THE RIGHT-OF-WAY AND UTILITY EASEMENT
 OWNED BY THE BRAZOS COUNTY
 TOTAL: ~~14464ft~~

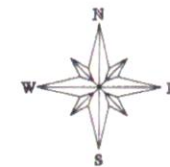

ENGINEERED FOR:



NO SCALE

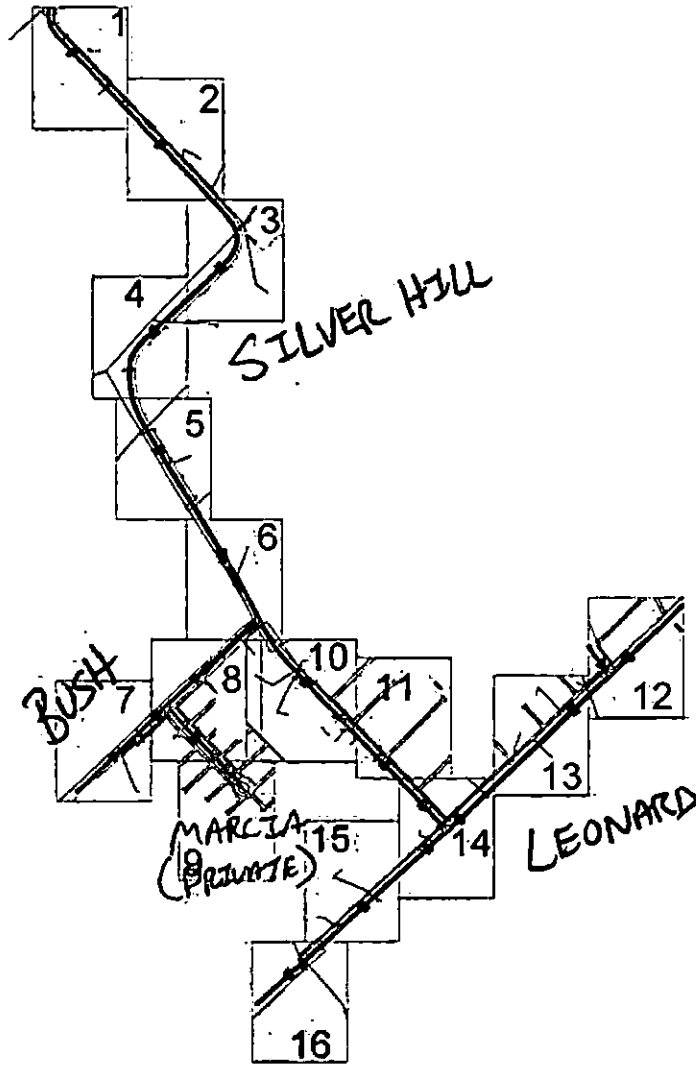

PREPARED BY:



QUASAR, INC.

COMCAST IS BORING AND INSTALLING NEW CONDUIT
 WITHIN THE RIGHT-OF-WAY AND UTILITY EASEMENT
 OWNED BY THE BRAZOS COUNTY
 TOTAL: 14464ft

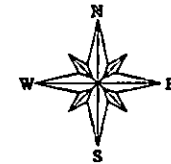

ENGINEERED FOR:



NO SCALE

NO MATCH SHEET

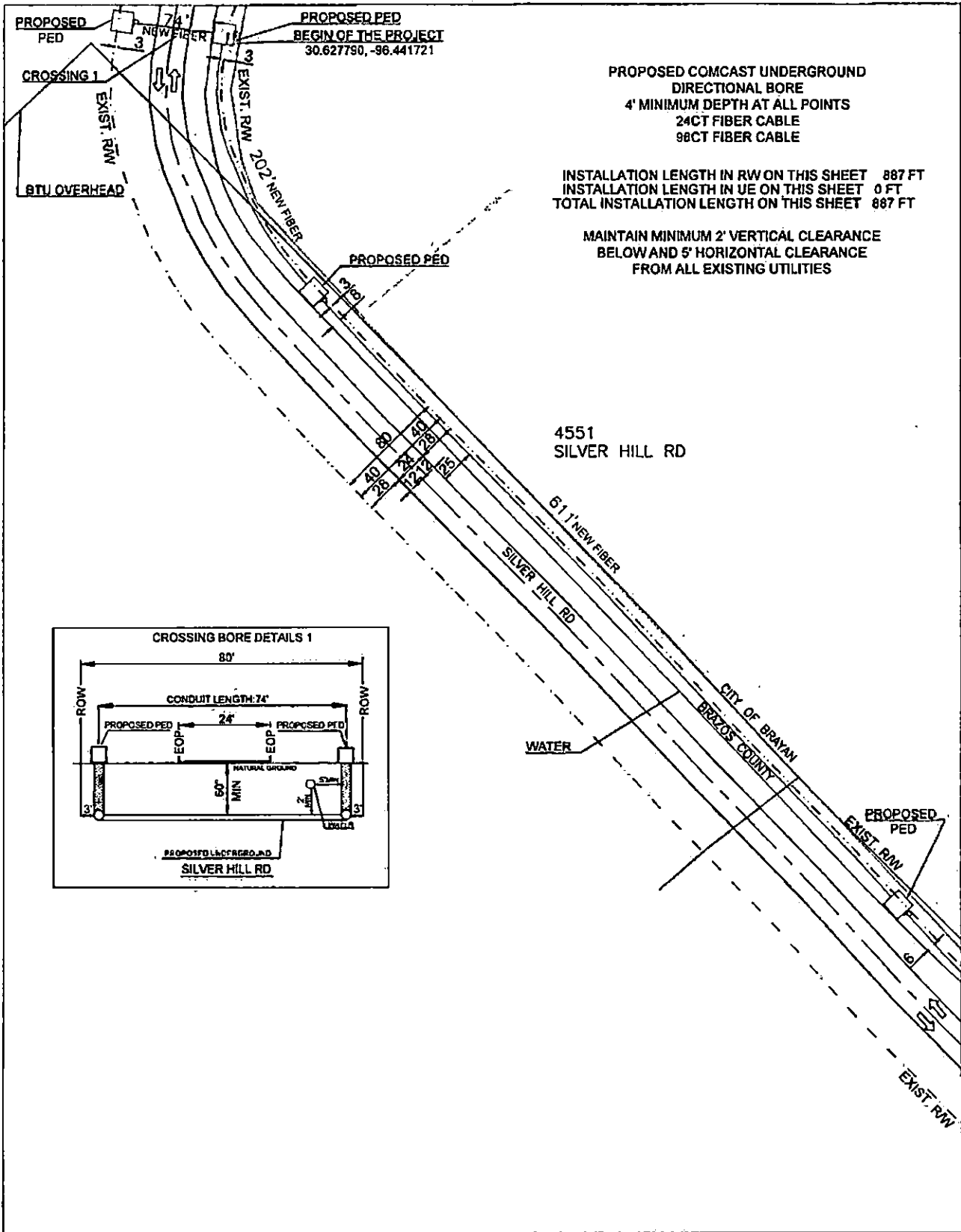

NO MATCH SHEET

MATCH SHEET 2

PROPOSED COMCAST UNDERGROUND
DIRECTIONAL BORE
4' MINIMUM DEPTH AT ALL POINTS
24CT FIBER CABLE
96CT FIBER CABLE

INSTALLATION LENGTH IN RW ON THIS SHEET 887 FT
INSTALLATION LENGTH IN UE ON THIS SHEET 0 FT
TOTAL INSTALLATION LENGTH ON THIS SHEET 887 FT

MAINTAIN MINIMUM 2' VERTICAL CLEARANCE
BELOW AND 5' HORIZONTAL CLEARANCE
FROM ALL EXISTING UTILITIES

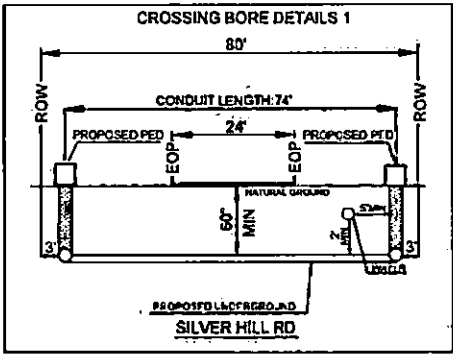

NO MATCH SHEET

PREPARED BY 	EXISTING POLE PROPOSED PEDESTAL WATER VALVE FIRE HYDRANT MANHOLE STORM DRAIN	RIGHT OF WAY LINE TELCO LANE WATER LANE GAS LANE EXISTING ANCHOR PROPOSED RISER	PROPOSED COAXIAL CABLE PROPOSED FIBER CABLE PROPOSED DIRECTIONAL BORE EXISTING CABLE UTILITY EASEMENT BTU UNDERGROUND BTU OVERHEAD		ENGINEERED FOR BRAZOS COUNTY SILVER HILL RD TRANSPORT FIBER		NO SCALE	SHEET 1 OF 16
	LEGEND RW - RIGHT OF WAY EOP - EDGE OF PAVEMENT DW - DRIVEWAY PDW - PAVED DRIVEWAY	NOTES: BORE HOLE TO BE FILLED SAME DAY VAULT HOLE TO BE FILLED SAME DAY ALL HOLES TO BE TAMPED AND FLOODED						

NO MATCH SHEET

PROPOSED COMCAST UNDERGROUND
DIRECTIONAL BORE
4' MINIMUM DEPTH AT ALL POINTS
24CT FIBER CABLE
86CT FIBER CABLE

INSTALLATION LENGTH IN RW ON THIS SHEET 1022 FT
INSTALLATION LENGTH IN UE ON THIS SHEET 0 FT
TOTAL INSTALLATION LENGTH ON THIS SHEET 1022 FT

MAINTAIN MINIMUM 2' VERTICAL CLEARANCE
BELOW AND 5' HORIZONTAL CLEARANCE
FROM ALL EXISTING UTILITIES

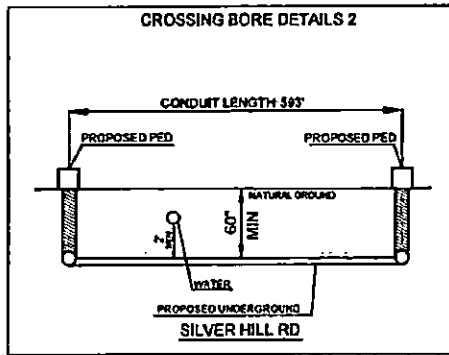

MATCH SHEET 1

NO MATCH SHEET

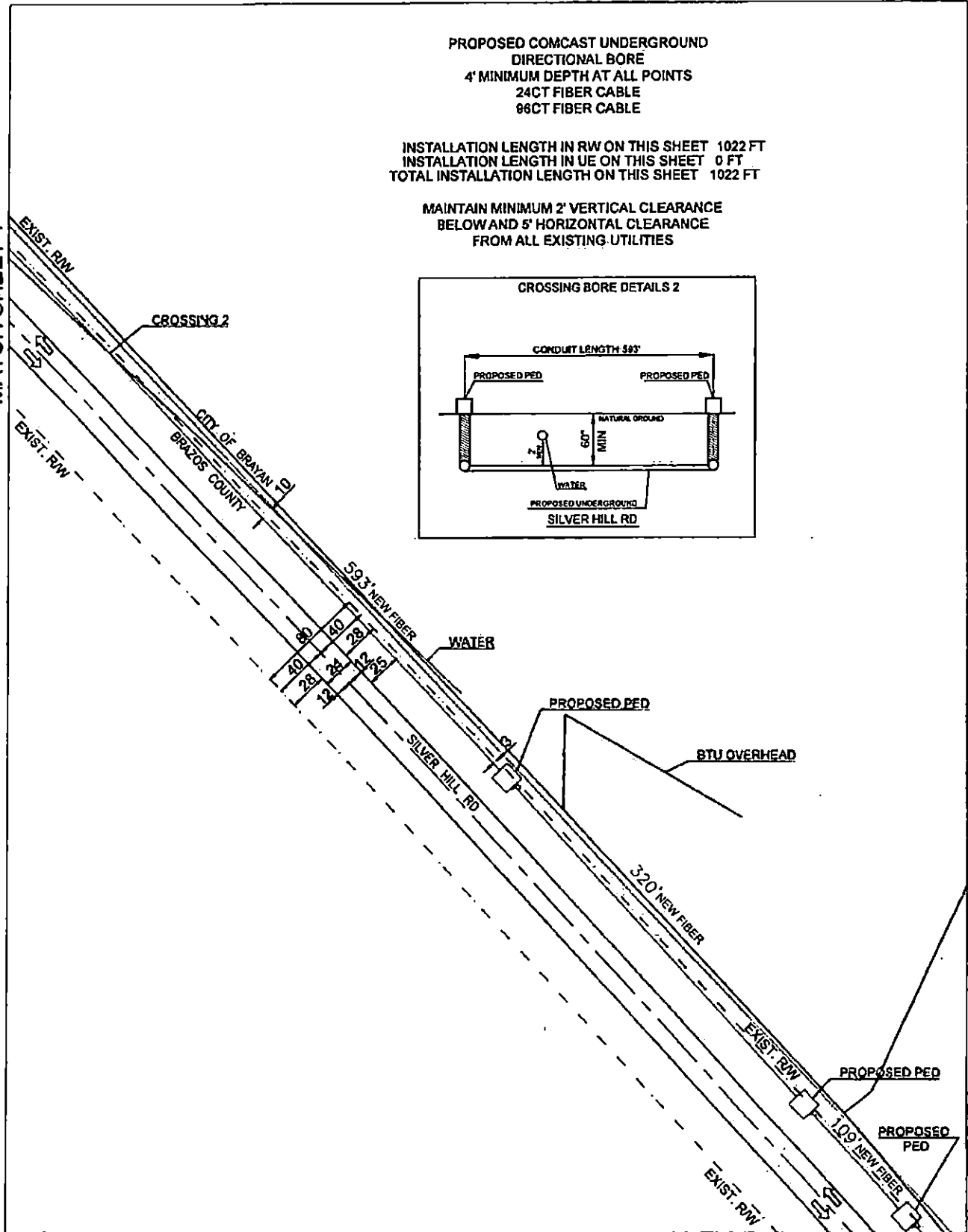

MATCH SHEET 3

PREPARED BY 				ENGINEERED FOR: BRAZOS COUNTY SILVER HILL RD TRANSPORT FIBER
	LEGEND RW - RIGHT OF WAY EOP - EDGE OF PAVEMENT EX - DRIVEWAY POW - PAVED DRIVEWAY	NOTES: BORE HOLES TO BE FILLED SAME DAY VAULT HOLES TO BE FILLED SAME DAY ALL HOLES TO BE TAMPED AND SLOPED		

MATCH SHEET 2

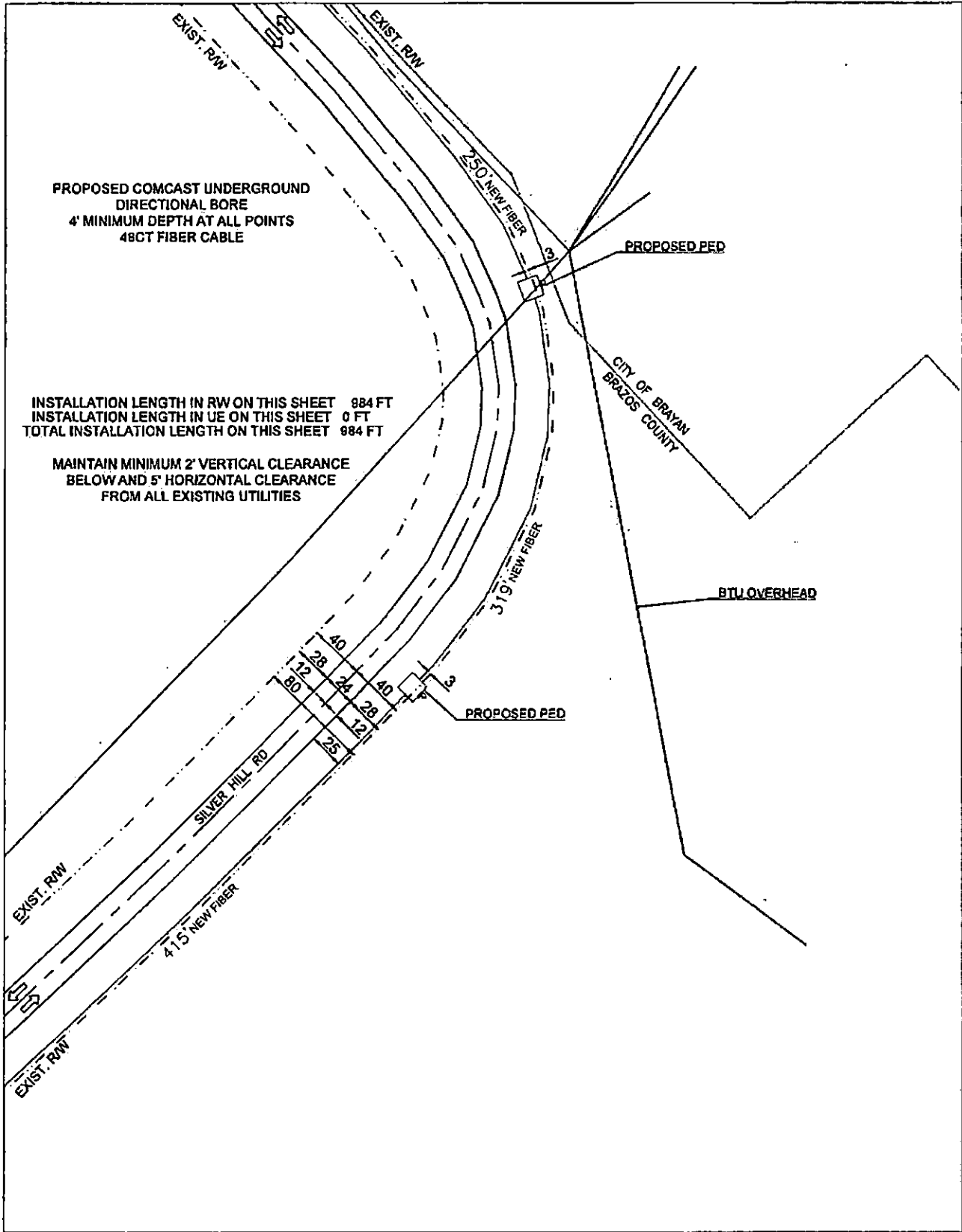

PROPOSED COMCAST UNDERGROUND
DIRECTIONAL BORE
4' MINIMUM DEPTH AT ALL POINTS
48CT FIBER CABLE

INSTALLATION LENGTH IN RW ON THIS SHEET 984 FT
INSTALLATION LENGTH IN UE ON THIS SHEET 0 FT
TOTAL INSTALLATION LENGTH ON THIS SHEET 984 FT

MAINTAIN MINIMUM 2' VERTICAL CLEARANCE
BELOW AND 5' HORIZONTAL CLEARANCE
FROM ALL EXISTING UTILITIES

MATCH SHEET 4

NO MATCH SHEET

NO MATCH SHEET

PREPARED BY 			ENGINEERED FOR 	BRAZOS COUNTY SILVER HILL RD TRANSPORT FIBER
	LEGEND: RW - RIGHT OF WAY EOP - EDGE OF PAVEMENT DW - DRIVEWAY PDM - PAVED DRIVEWAY	NOTES: BONE HOLE TO BE FILLED SAME DAY VAULT HOLE TO BE FILLED SAME DAY ALL HOLE TO BE TAPPED AND SLOTTED		

NO MATCH SHEET

PROPOSED COMCAST UNDERGROUND
DIRECTIONAL BORE
4' MINIMUM DEPTH AT ALL POINTS
24CT FIBER CABLE
48CT FIBER CABLE

INSTALLATION LENGTH IN RW ON THIS SHEET 910 FT
INSTALLATION LENGTH IN UE ON THIS SHEET 0 FT
TOTAL INSTALLATION LENGTH ON THIS SHEET 910 FT

MAINTAIN MINIMUM 2' VERTICAL CLEARANCE
BELOW AND 5' HORIZONTAL CLEARANCE
FROM ALL EXISTING UTILITIES

NO MATCH SHEET

MATCH SHEET 3

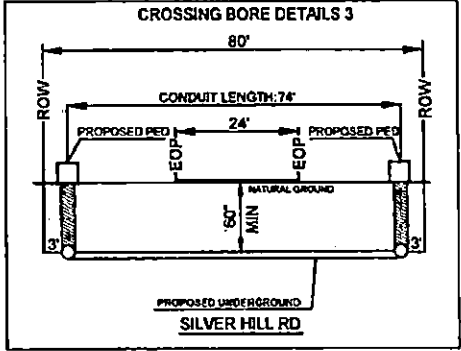
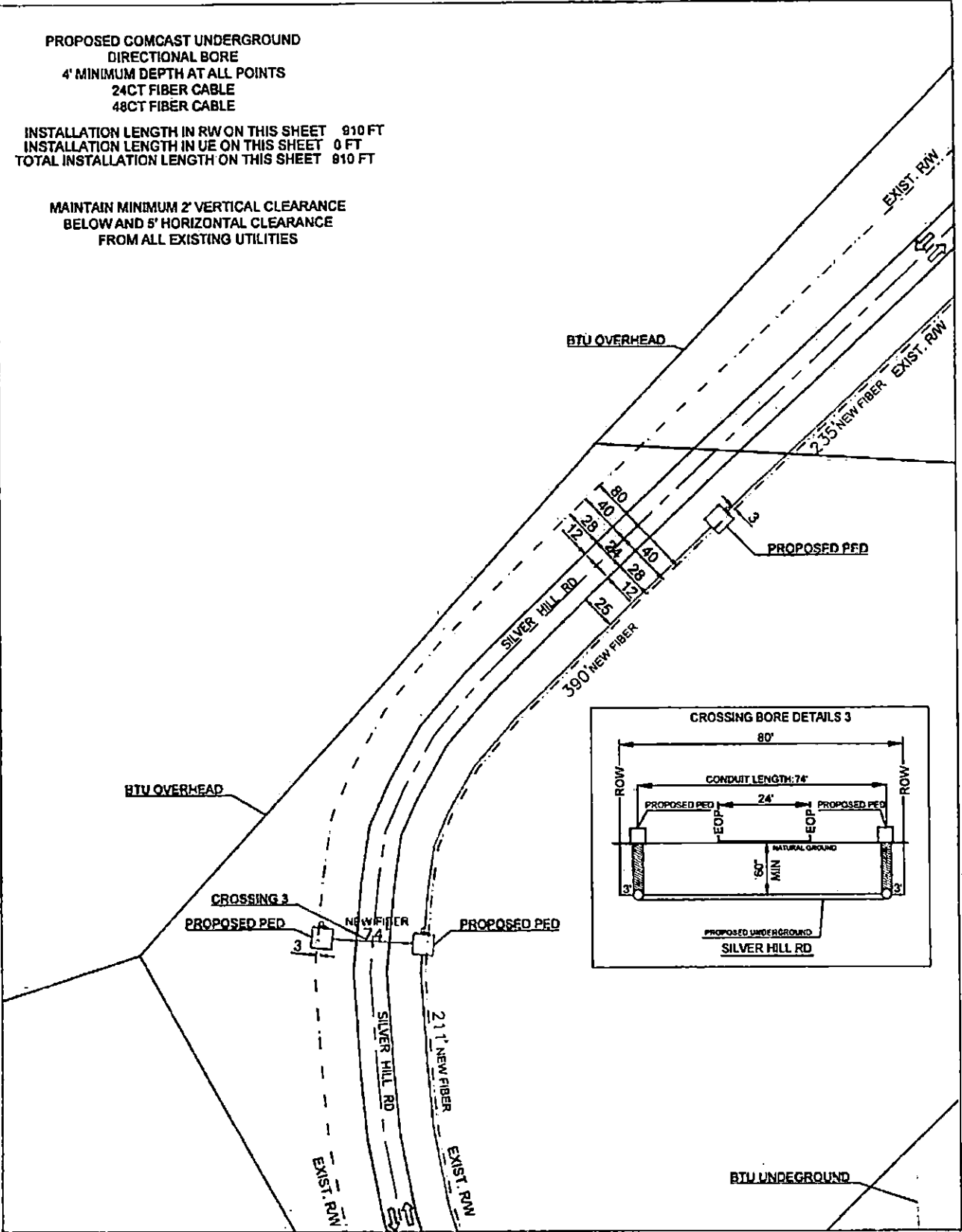

MATCH SHEET 5

PREPARED BY 				ENGINEERED FOR 	BRAZOS COUNTY SILVER HILL RD TRANSPORT FIBER
	LEGEND: RW - RIGHT OF WAY EOP - EDGE OF PAVEMENT EDW - DRIVEWAY EDW - PAVED DRIVEWAY	NOTES: BORE HOLE TO BE FILLED SAME DAY WALK HOLE TO BE FILLED SAME DAY ALL HOLES TO BE TAPPED AND EGGED		NO SCALE	SHEET 6 OF 10

MATCH SHEET 4

PROPOSED COMCAST UNDERGROUND
DIRECTIONAL BORE
4' MINIMUM DEPTH AT ALL POINTS
24CT FIBER CABLE
48CT FIBER CABLE

INSTALLATION LENGTH IN RW ON THIS SHEET 1105 FT
INSTALLATION LENGTH IN UE ON THIS SHEET 0 FT
TOTAL INSTALLATION LENGTH ON THIS SHEET 1105 FT

MAINTAIN MINIMUM 2' VERTICAL CLEARANCE
BELOW AND 5' HORIZONTAL CLEARANCE
FROM ALL EXISTING UTILITIES

NO MATCH SHEET

NO MATCH SHEET

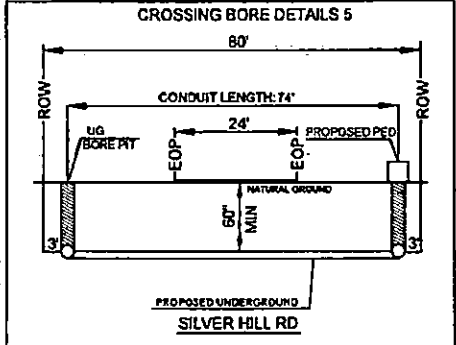
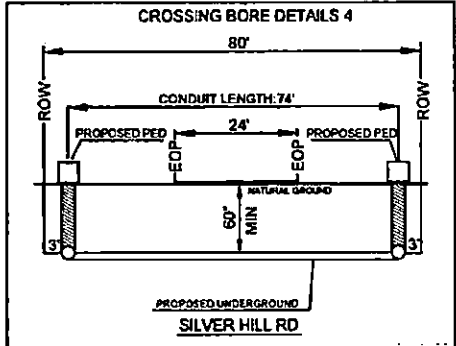
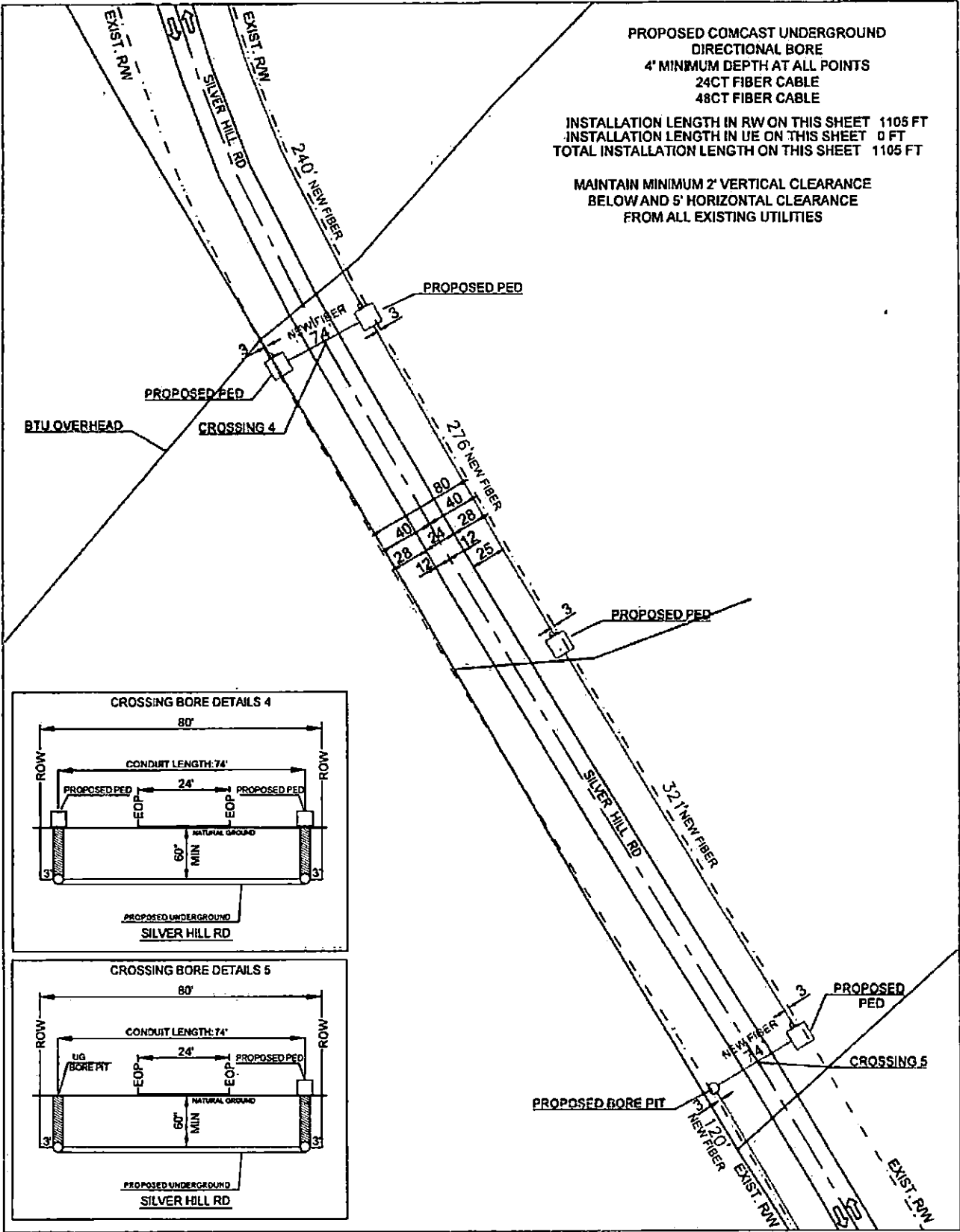

MATCH SHEET 6

PREPARED BY: 	EXISTING POLE PROPOSED PEDESTAL WATER VALVE FIRE HYDRANT MANHOLE STORM DRAIN	RIGHT OF WAY LINE TELOED LANE WATER LANE GAS LANE EXISTING ANCHOR PROPOSED FUSER	PROPOSED CONDUIT CABLE PROPOSED FIBER CABLE PROPOSED DIRECTIONAL BORE EXISTING CABLE UTILITY EASEMENT BTU UNDERGROUND BTU OVERHEAD		ENGINEERED FOR 	BRAZOS COUNTY SILVER HILL RD TRANSPORT FIBER
	LEGEND RW - RIGHT OF WAY EOP - EDGE OF PAVEMENT DW - DRIVEWAY POW - PAVED DRIVEWAY	NOTES: BORE HOLE TO BE FILLED SAME DAY VAULT HOLE TO BE FILLED SAME DAY ALL HOLES TO BE TAMPED AND SODDED	NO SCALE SHEETS OF 14			

MATCH SHEET 5

NO MATCH SHEET

NO MATCH SHEET

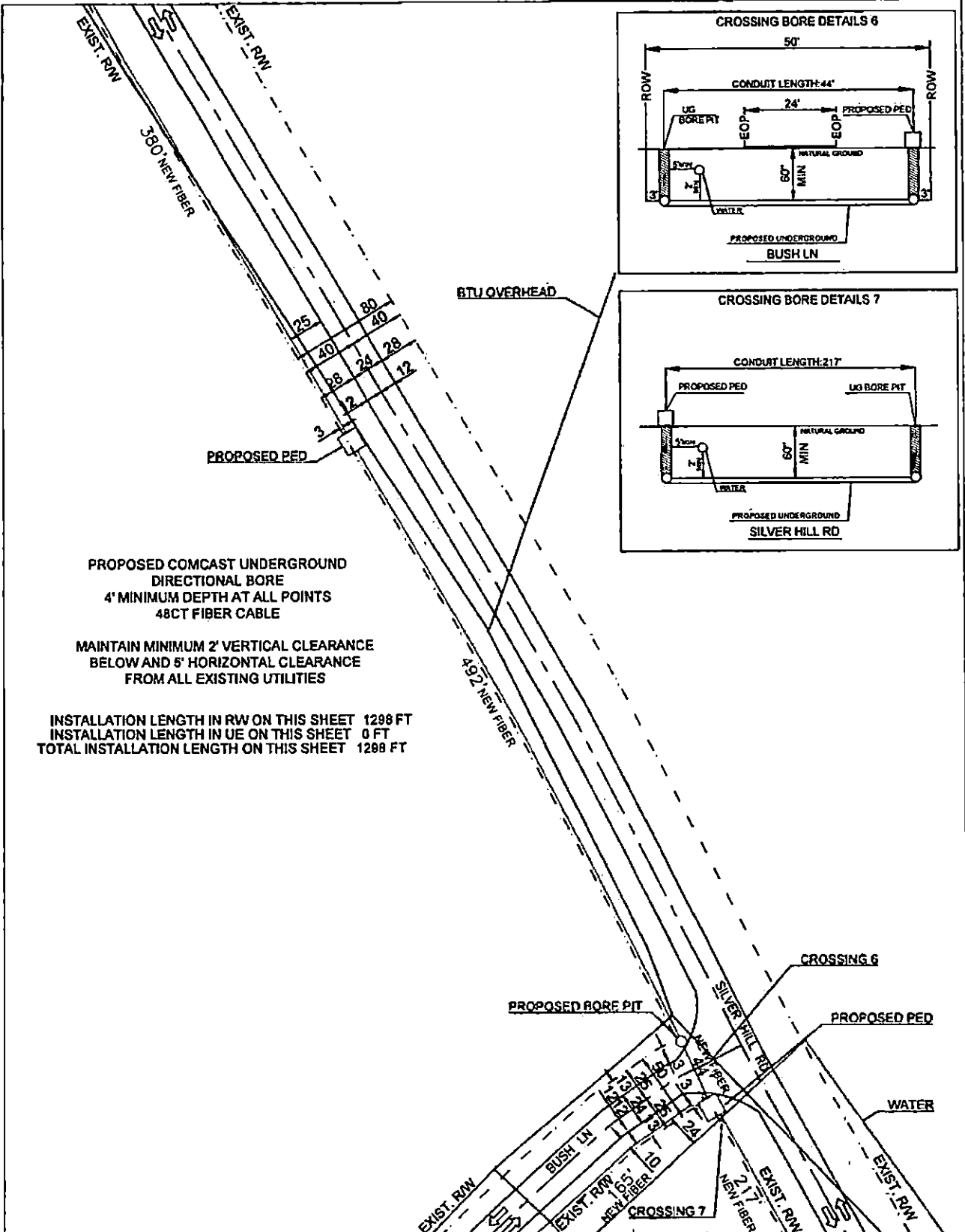

PROPOSED COMCAST UNDERGROUND DIRECTIONAL BORE 4' MINIMUM DEPTH AT ALL POINTS 48CT FIBER CABLE

MAINTAIN MINIMUM 2' VERTICAL CLEARANCE BELOW AND 5' HORIZONTAL CLEARANCE FROM ALL EXISTING UTILITIES

INSTALLATION LENGTH IN RW ON THIS SHEET 1298 FT
 INSTALLATION LENGTH IN UE ON THIS SHEET 0 FT
 TOTAL INSTALLATION LENGTH ON THIS SHEET 1298 FT

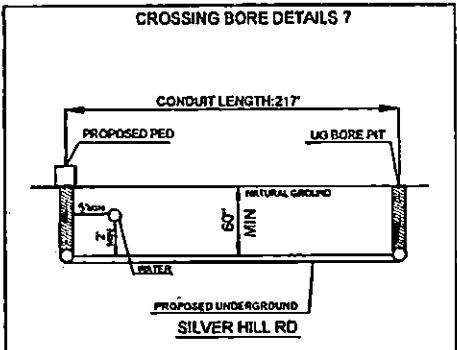
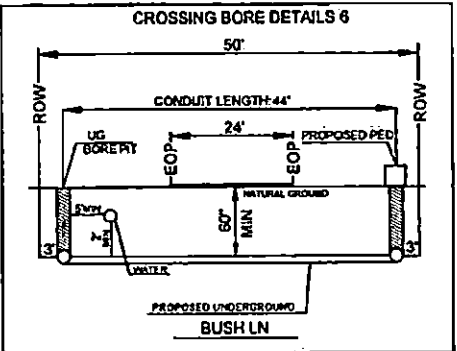

MATCH SHEET 8

MATCH SHEET 10

PREPARED BY 	EXISTING POLE PROPOSED PEDESTAL WATER VALVE FIRE HYDRANT MANHOLE STORM DRAIN	RIGHT OF WAY LINE TELEO LANE WATER LANE GAS LANE EXISTING ANCHOR PROPOSED HOLE	PROPOSED COAXIAL CABLE PROPOSED FIBER CABLE PROPOSED DIRECTIONAL BORE EXISTING CABLE UTILITY EASEMENT BTU UNDERGROUND BTU OVERHEAD		ENGINEERED FOR 	BRAZOS COUNTY SILVER HILL RD BUSH LN TRANSPORT FIBER
	LEGEND RW - RIGHT OF WAY EOP - EDGE OF PAVEMENT LW - DRIVEWAY ROW - PAVED DRIVEWAY				NOTES BORE HOLE TO BE FILLED SAME DAY VAULT HOLE TO BE FILLED SAME DAY ALL HOLES TO BE TAMPED AND ERODED	NO SCALE SHEET 6 OF 18

NO MATCH SHEET

PROPOSED COMCAST UNDERGROUND
DIRECTIONAL BORE
4' MINIMUM DEPTH AT ALL POINTS
24CT FIBER CABLE

INSTALLATION LENGTH IN RW ON THIS SHEET 110 FT
INSTALLATION LENGTH IN UE ON THIS SHEET 164 FT
TOTAL INSTALLATION LENGTH ON THIS SHEET 274 FT

MAINTAIN MINIMUM 2' VERTICAL CLEARANCE
BELOW AND 5' HORIZONTAL CLEARANCE
FROM ALL EXISTING UTILITIES

NO MATCH SHEET

MATCH SHEET 8

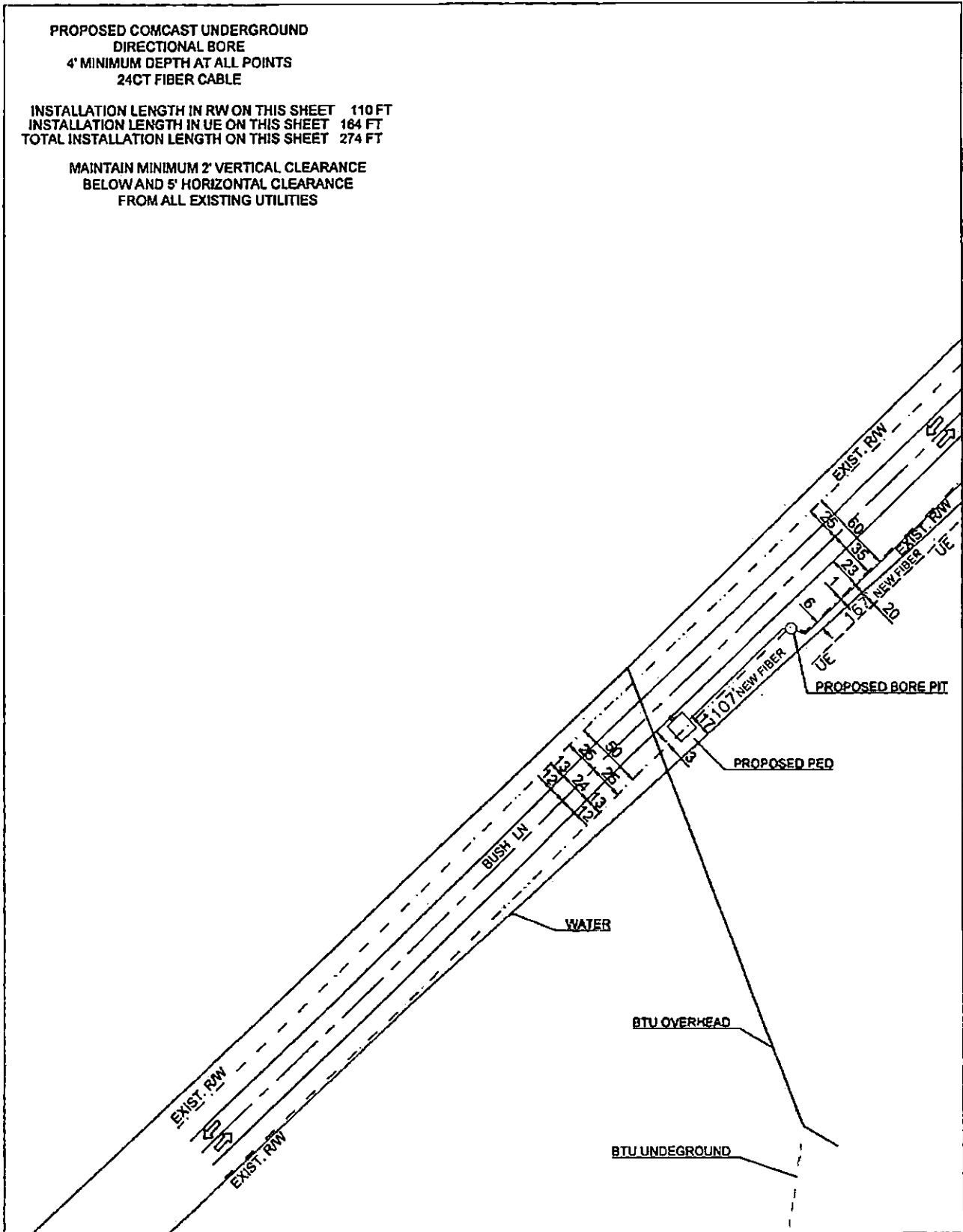

NO MATCH SHEET

PREPARED BY 	EXISTING POLE PROPOSED PEDESTAL WATER VALVE FIRE HYDRANT MANHOLE STORM DRAIN	RIGHT OF WAY LINE TELCO LANE WATER LANE GAS LANE EXISTING ANCHOR PROPOSED FIBER	PROPOSED COAXIAL CABLE PROPOSED FIBER CABLE PROPOSED DIRECTIONAL BORE EXISTING CABLE UTILITY EASEMENT BTU UNDERGROUND BTU OVERHEAD		ENGINEERED FOR 	BRAZOS COUNTY BUSH LN TRANSPORT FIBER
	LEGEND RW - RIGHT OF WAY EOP - EDGE OF PAVEMENT DW - DRIVEWAY PDM - PAVED DRIVEWAY	NOTES BORE HOLE TO BE FILLED SAME DAY VAULT HOLE TO BE FILLED SAME DAY ALL HOLE TO BE TAPPED AND EXPANDED	NO SCALE		SHEET 7 OF 18	

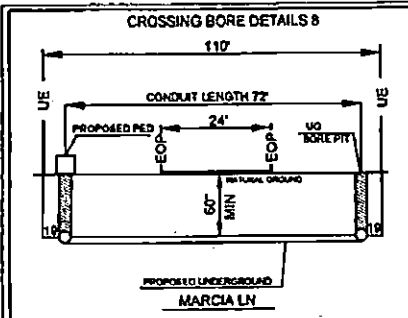

PROPOSED COMCAST UNDERGROUND
DIRECTIONAL BORE
4' MINIMUM DEPTH AT ALL POINTS
24CT FIBER CABLE
48CT FIBER CABLE

INSTALLATION LENGTH IN RW ON THIS SHEET 580 FT
INSTALLATION LENGTH IN UE ON THIS SHEET 943 FT
TOTAL INSTALLATION LENGTH ON THIS SHEET 1523 FT

MAINTAIN MINIMUM 2' VERTICAL CLEARANCE
BELOW AND 5' HORIZONTAL CLEARANCE
FROM ALL EXISTING UTILITIES

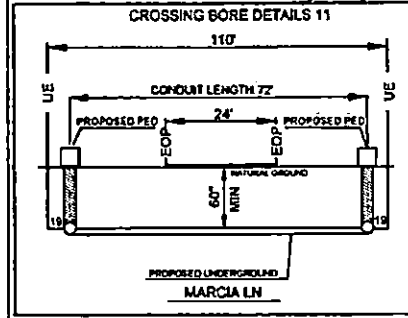
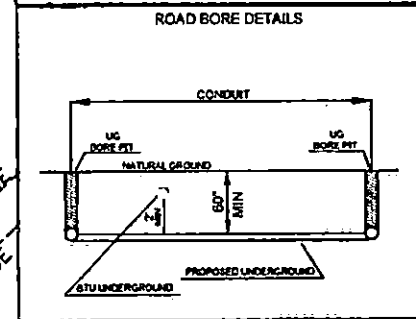
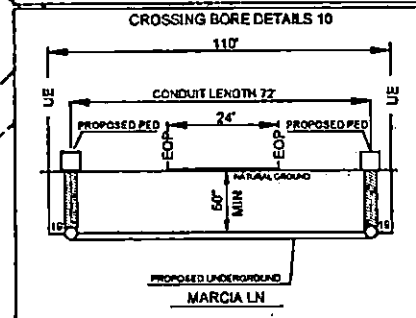
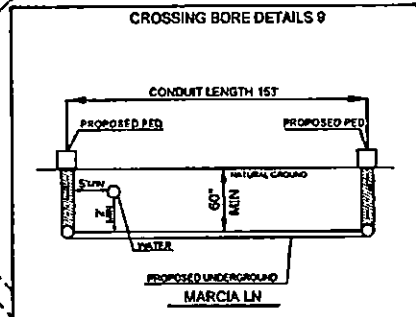

MATCH SHEET 7

NO MATCH SHEET

MATCH SHEET 9

<p>PREPARED BY</p> <p>QUASAR, INC.</p>	<p>EXISTING POLE</p> <p>PROPOSED PEDESTAL</p> <p>WATER VALVE</p> <p>FIRE HYDRANT</p> <p>MANHOLE</p> <p>STORM DRAIN</p>	<p>RIGHT OF WAY LINE</p> <p>TELCO LANE</p> <p>WATER LANE</p> <p>GAS LANE</p> <p>EXISTING ANCHOR</p> <p>PROPOSED FIBER</p>	<p>PROPOSED COAXIAL CABLE</p> <p>PROPOSED FIBER CABLE</p> <p>PROPOSED DIRECTIONAL BORE</p> <p>EXISTING CABLE</p> <p>UTILITY EASEMENT</p> <p>STU UNDERGROUND</p> <p>STU OVERHEAD</p>		<p>ENGINEERED FOR</p> <p>COMCAST</p>	<p>BRAGGS COUNTY</p> <p>MARCIA LN</p> <p>BUSH LN</p> <p>TRANSPORT FIBER</p>
	<p>LEGEND</p> <p>RW - RIGHT OF WAY</p> <p>TOP - EDGE OF PAVEMENT</p> <p>DR - DRIVEWAY</p> <p>PDW - PAVED DRIVEWAY</p>	<p>NOTES</p> <p>BORE HOLE TO BE FILLED SAME DAY</p> <p>VAULT HOLE TO BE FILLED SAME DAY</p> <p>ALL HOLES TO BE TAMPED AND ROLLED</p>	<p>NO SCALE</p> <p>SHEET 9 OF 16</p>			

MATCH SHEET 8

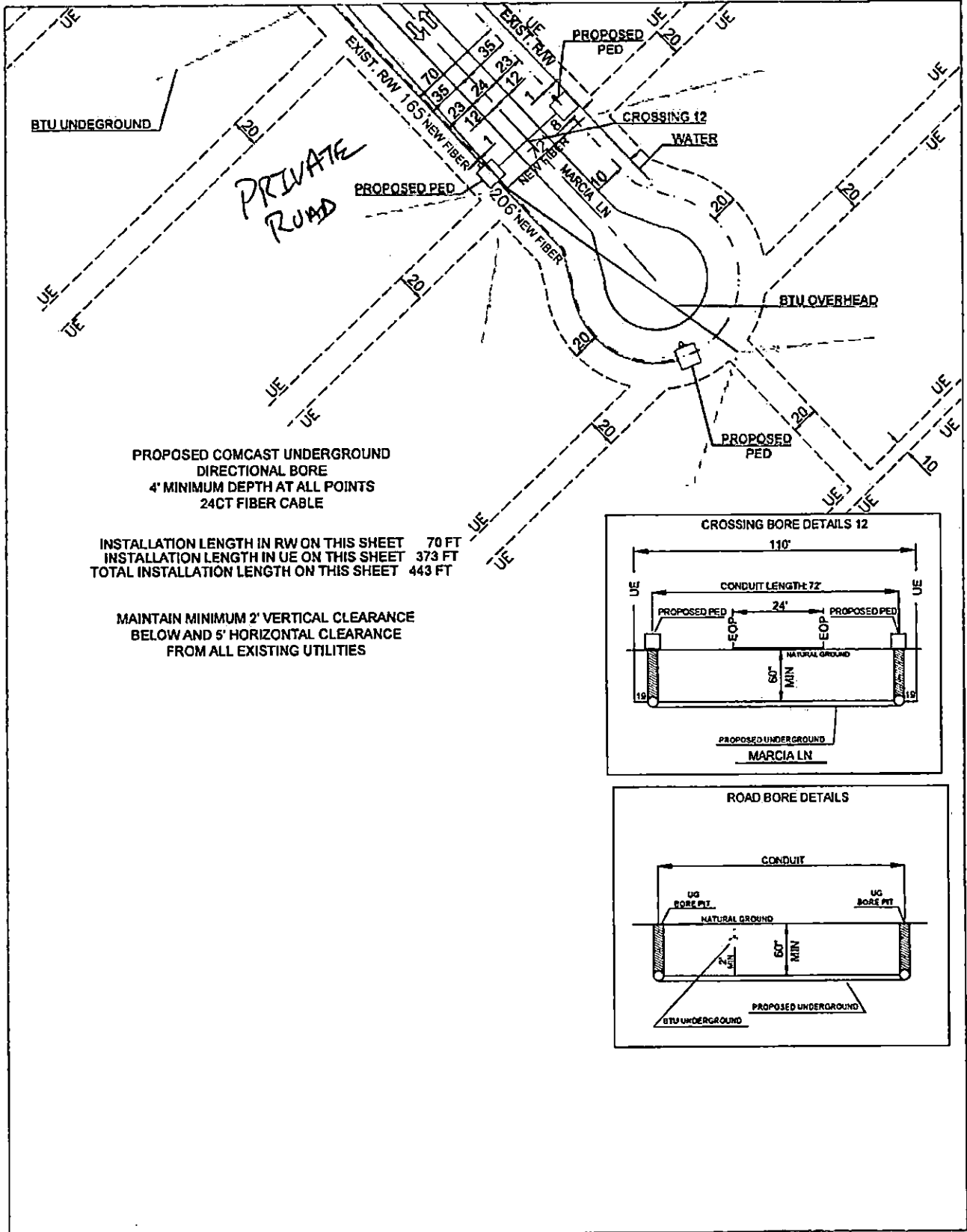

NO MATCH SHEET

NO MATCH SHEET

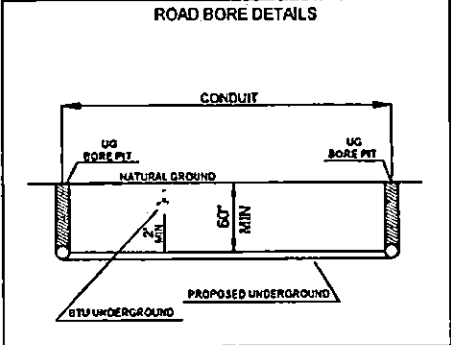
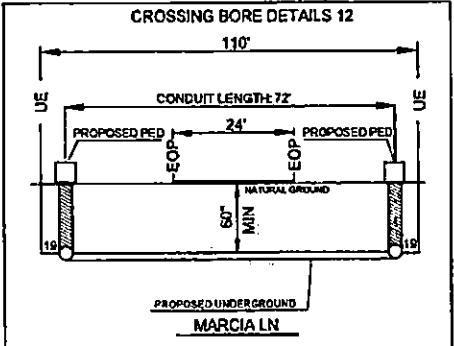

NO MATCH SHEET

<p>PREPARED BY</p> <p>QUASAR, INC.</p>	<p>EXISTING POLE</p> <p>PROPOSED PEDESTAL</p> <p>WATER VALVE</p> <p>FIRE HYDRANT</p> <p>MANHOLE</p> <p>STORM DRAIN</p>	<p>RIGHT OF WAY LINE</p> <p>TELCO LANE</p> <p>WATER LANE</p> <p>GAS LANE</p> <p>EXISTING ANCHOR</p> <p>PROPOSED JOCKER</p>	<p>PROPOSED COAXIAL CABLE</p> <p>PROPOSED FIBER CABLE</p> <p>PROPOSED DIRECTIONAL BORE</p> <p>EXISTING CABLE</p> <p>UTILITY EASEMENT</p> <p>BTU UNDERGROUND</p> <p>BTU OVERHEAD</p>		<p>ENGINEERED FOR.</p> <p>BRAZOS COUNTY</p> <p>MARCIA LN</p> <p>TRANSPORT FIBER</p>		<p>NO SCALE</p>	<p>SHEET 8 OF 18</p>
	<p>LEGEND:</p> <p>R/W - RIGHT OF WAY</p> <p>EOP - EDGE OF PAVEMENT</p> <p>OW - DRIVEWAY</p> <p>P/W - PAVED DRIVEWAY</p>	<p>NOTES:</p> <p>DO NOT HOLE TO BE FILLED SAME DAY</p> <p>VALVE HOLE TO BE FILLED SAME DAY</p> <p>ALL HOLES TO BE TAMPED AND BONDED</p>	<p>COMCAST</p>					

MATCH SHEET 6

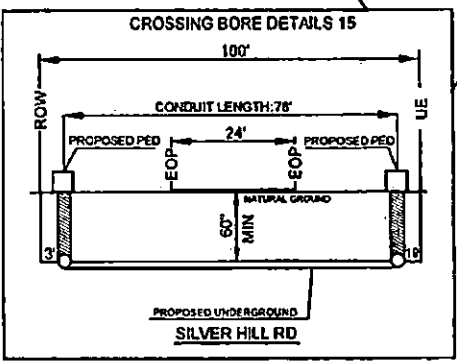
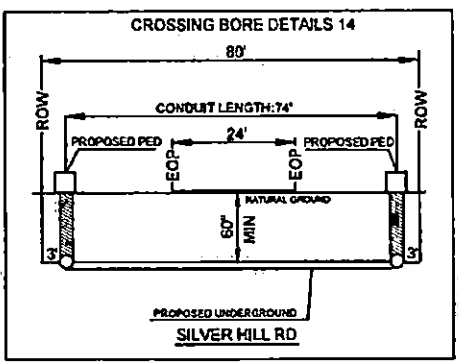
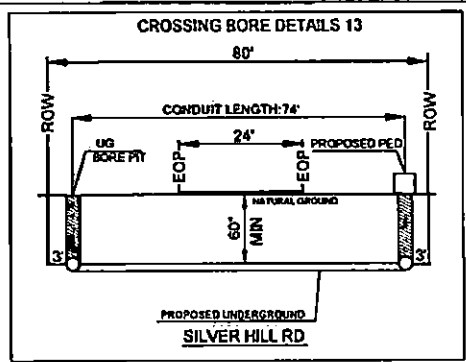
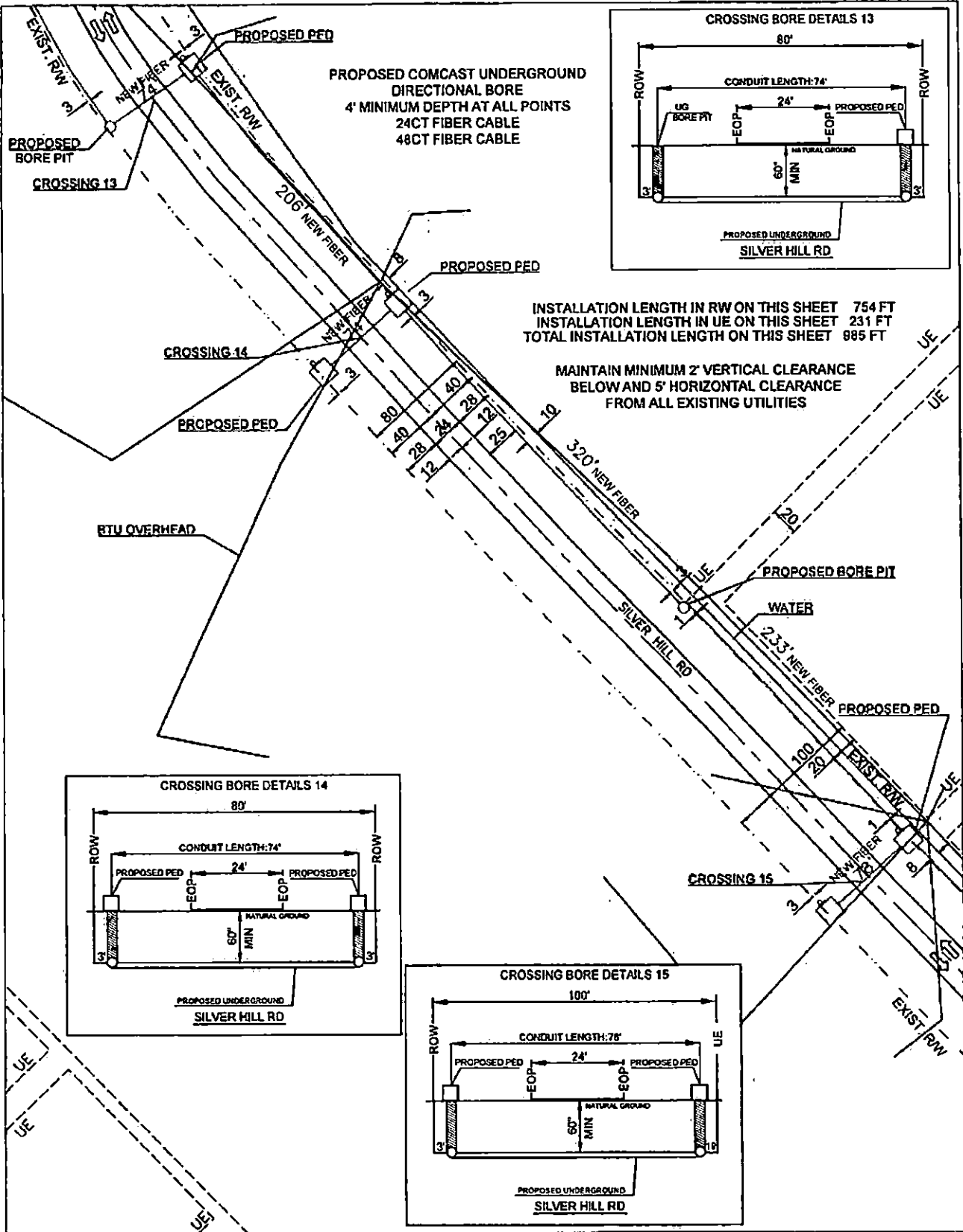

INSTALLATION LENGTH IN RW ON THIS SHEET 754 FT
 INSTALLATION LENGTH IN UE ON THIS SHEET 231 FT
 TOTAL INSTALLATION LENGTH ON THIS SHEET 985 FT

MAINTAIN MINIMUM 2' VERTICAL CLEARANCE
 BELOW AND 5' HORIZONTAL CLEARANCE
 FROM ALL EXISTING UTILITIES

NO MATCH SHEET

MATCH SHEET 11

NO MATCH SHEET

PREPARED BY 	X ⊗ ⊕ EXISTING POLE □ PROPOSED PEDESTAL (W) WATER VALVE (F) FIRE HYDRANT (M) MANHOLE (S) STORM DRAIN	--- RIGHT OF WAY LINE --- TELCO LANE --- WATER LANE --- GAS LANE --- EXISTING ANCHOR --- PROPOSED PISER	--- PROPOSED COAXIAL CABLE --- PROPOSED FIBER CABLE --- PROPOSED DIRECTIONAL BORE --- EXISTING CABLE --- UTILITY EASEMENT --- STU UNDERGROUND --- BTU OVERHEAD		ENGINEERED FOR 	BRAZOS COUNTY SILVER HILL RD TRANSPORT FIBER
	LEGEND RW - RIGHT OF WAY EOP - EDGE OF PAVEMENT LW - DRIVEWAY POW - PAVED DRIVEWAY	NOTES: BORE HOLES TO BE FILLED SAME DAY VAULT HOLES TO BE FILLED SAME DAY ALL HOLES TO BE TAMPER AND ERODED	NO SCALE SHEET 18 OF 18			

NO MATCH SHEET

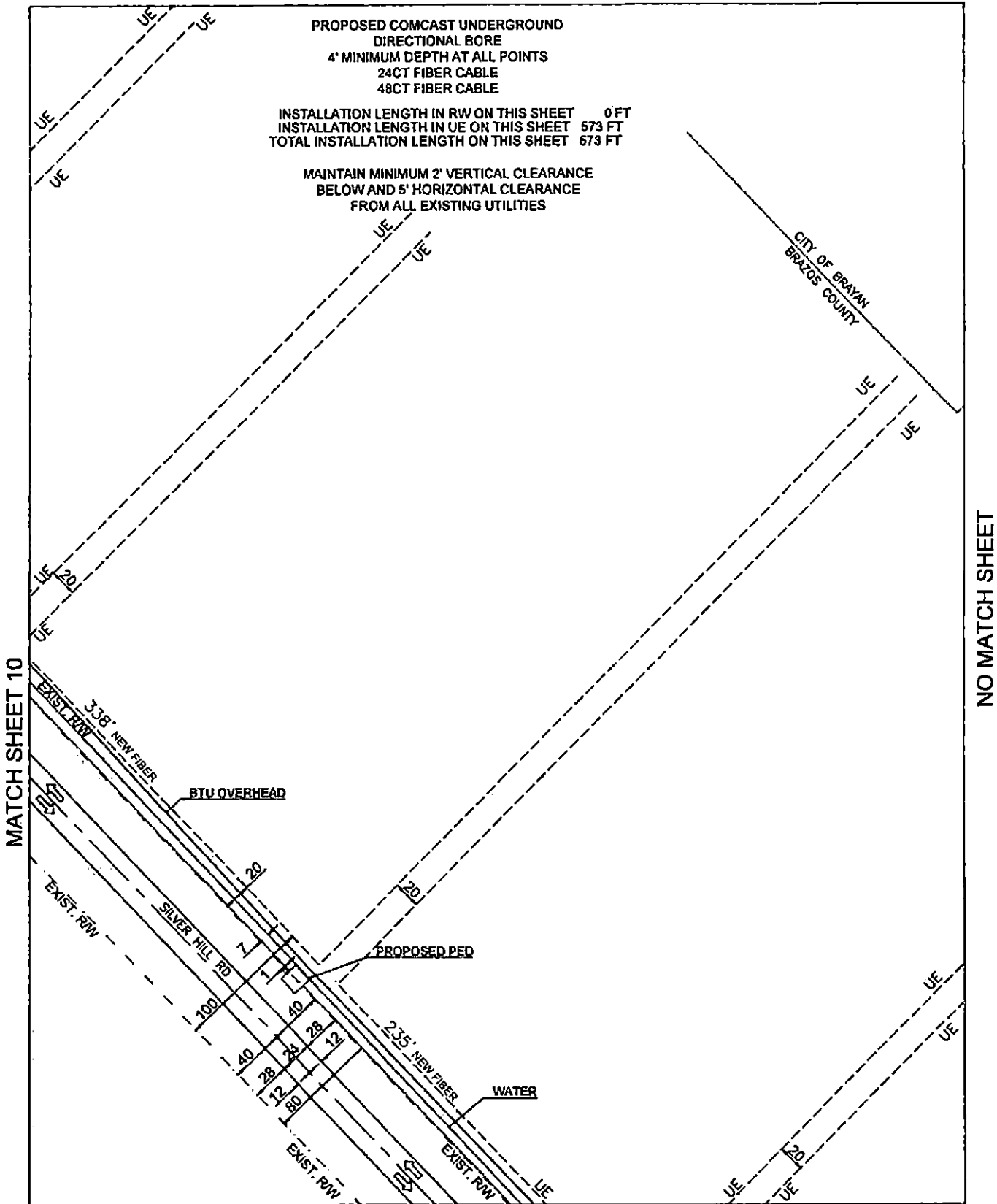

PREPARED BY QUASAR, INC.	<table border="0"> <tr> <td style="font-size: 8px;"> X [] EXISTING POLE [] PROPOSED PEDESTAL [] WATER VALVE [] FIRE HYDRANT [] MANHOLE [] STORM DRAIN </td> <td style="font-size: 8px;"> --- RIGHT OF WAY LINE --- TELCO LANE --- WATER LANE --- GAS LANE --- EXISTING ANCHOR --- PROPOSED RISER </td> <td style="font-size: 8px;"> --- PROPOSED COAXIAL CABLE --- PROPOSED FIBER CABLE --- PROPOSED DIRECTIONAL BORE --- EXISTING CABLE --- UTILITY EASEMENT --- BTU UNDERGROUND --- BTU OVERHEAD </td> </tr> </table>	X [] EXISTING POLE [] PROPOSED PEDESTAL [] WATER VALVE [] FIRE HYDRANT [] MANHOLE [] STORM DRAIN	--- RIGHT OF WAY LINE --- TELCO LANE --- WATER LANE --- GAS LANE --- EXISTING ANCHOR --- PROPOSED RISER	--- PROPOSED COAXIAL CABLE --- PROPOSED FIBER CABLE --- PROPOSED DIRECTIONAL BORE --- EXISTING CABLE --- UTILITY EASEMENT --- BTU UNDERGROUND --- BTU OVERHEAD		ENGINEERED FOR COMCAST	BRAZOS COUNTY SILVER HILL RD TRANSPORT FIBER NO SCALE SHEET 11 OF 19
X [] EXISTING POLE [] PROPOSED PEDESTAL [] WATER VALVE [] FIRE HYDRANT [] MANHOLE [] STORM DRAIN	--- RIGHT OF WAY LINE --- TELCO LANE --- WATER LANE --- GAS LANE --- EXISTING ANCHOR --- PROPOSED RISER	--- PROPOSED COAXIAL CABLE --- PROPOSED FIBER CABLE --- PROPOSED DIRECTIONAL BORE --- EXISTING CABLE --- UTILITY EASEMENT --- BTU UNDERGROUND --- BTU OVERHEAD					
LEGEND: RW - RIGHT OF WAY EOP - EDGE OF PAVEMENT DPT - DRIVEWAY POW - PAVED DRIVEWAY		NOTES: BORE HOLE TO BE FILLED SAME DAY VAULT HOLE TO BE FILLED SAME DAY ALL HOLE TO BE TAMPED AND SODDED					

NO MATCH SHEET

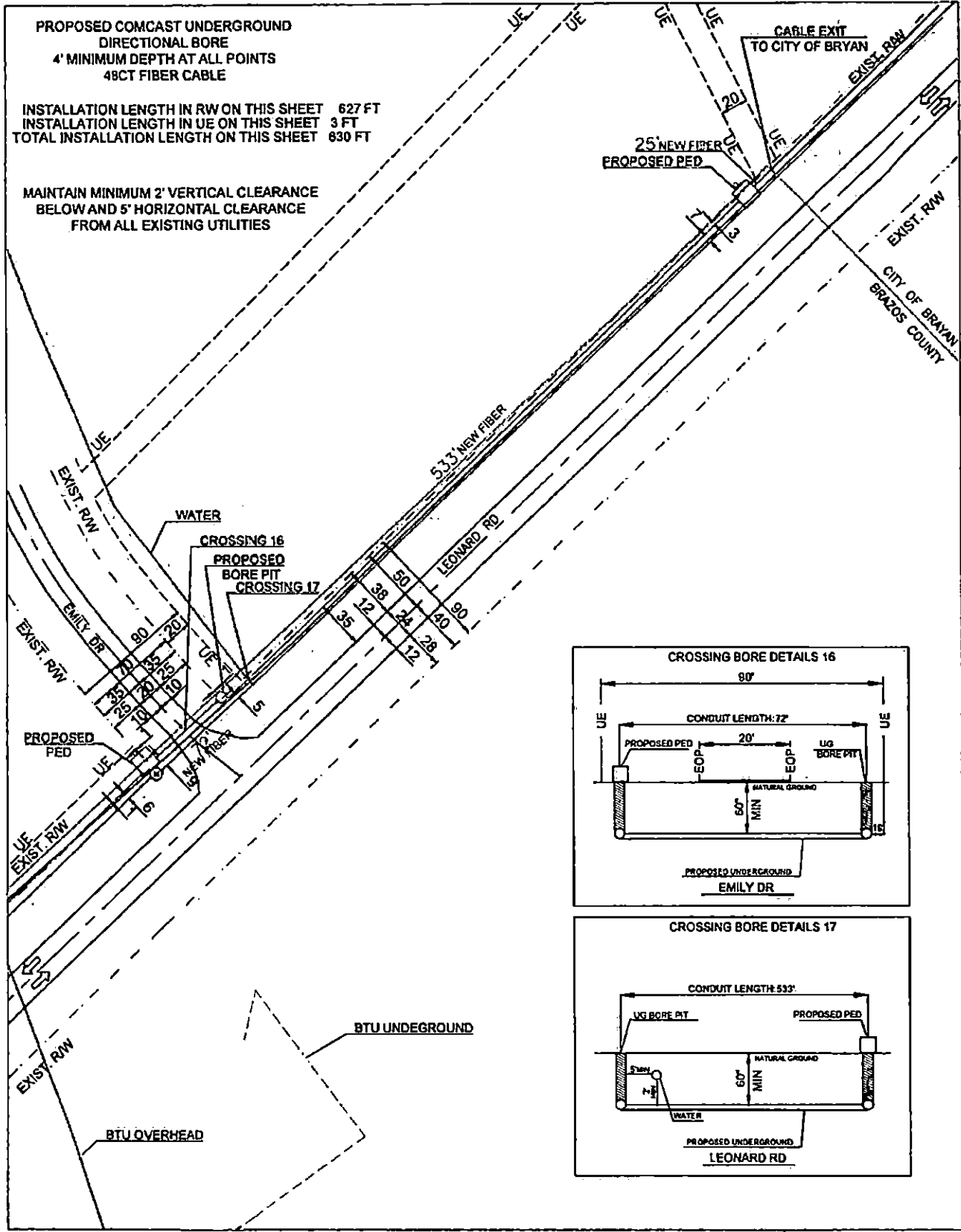

PROPOSED COMCAST UNDERGROUND
DIRECTIONAL BORE
4' MINIMUM DEPTH AT ALL POINTS
48CT FIBER CABLE

INSTALLATION LENGTH IN RW ON THIS SHEET 627 FT
INSTALLATION LENGTH IN UE ON THIS SHEET 3 FT
TOTAL INSTALLATION LENGTH ON THIS SHEET 630 FT

MAINTAIN MINIMUM 2' VERTICAL CLEARANCE
BELOW AND 5' HORIZONTAL CLEARANCE
FROM ALL EXISTING UTILITIES

CABLE EXIT
TO CITY OF BRYAN

25' NEW FIBER
PROPOSED PED

533' NEW FIBER
LEONARD RD

WATER
CROSSING 16

PROPOSED
BORE PIT
CROSSING 17

PROPOSED
PED

BTU UNDERGROUND

BTU OVERHEAD

CROSSING BORE DETAILS 16

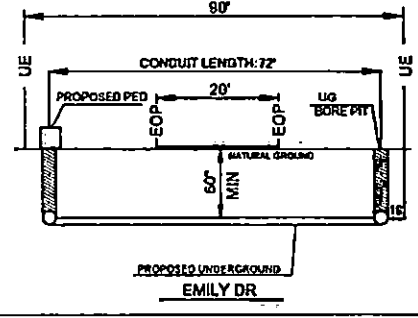

CROSSING BORE DETAILS 17

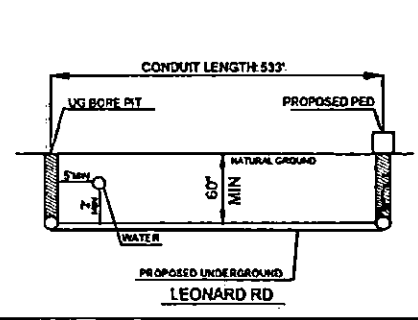

MATCH SHEET 13

NO MATCH SHEET

NO MATCH SHEET

<p>PREPARED BY</p> <p>QUASAR, INC.</p>	<p>LEGEND</p> <ul style="list-style-type: none"> EXISTING POLE PROPOSED PEDESTAL WATER VALVE FIRE HYDRANT MANHOLE STORM DRAIN 	<p>NOTES</p> <ul style="list-style-type: none"> BORE HOLES TO BE FILLED SAME DAY VAULT HOLES TO BE FILLED SAME DAY ALL HOLES TO BE TAMPED AND BODDED 	<p>ENGINEERED FOR</p> <p>COMCAST</p>	<p>BRAZOS COUNTY LEONARD RD, EMILY DR TRANSPORT FIBER</p>

NO MATCH SHEET

PROPOSED COMCAST UNDERGROUND
DIRECTIONAL BORE
4' MINIMUM DEPTH AT ALL POINTS
24CT FIBER CABLE
48CT FIBER CABLE

INSTALLATION LENGTH IN RW ON THIS SHEET 0 FT
INSTALLATION LENGTH IN UE ON THIS SHEET 1088 FT
TOTAL INSTALLATION LENGTH ON THIS SHEET 1088 FT

MAINTAIN MINIMUM 2' VERTICAL CLEARANCE
BELOW AND 5' HORIZONTAL CLEARANCE
FROM ALL EXISTING UTILITIES

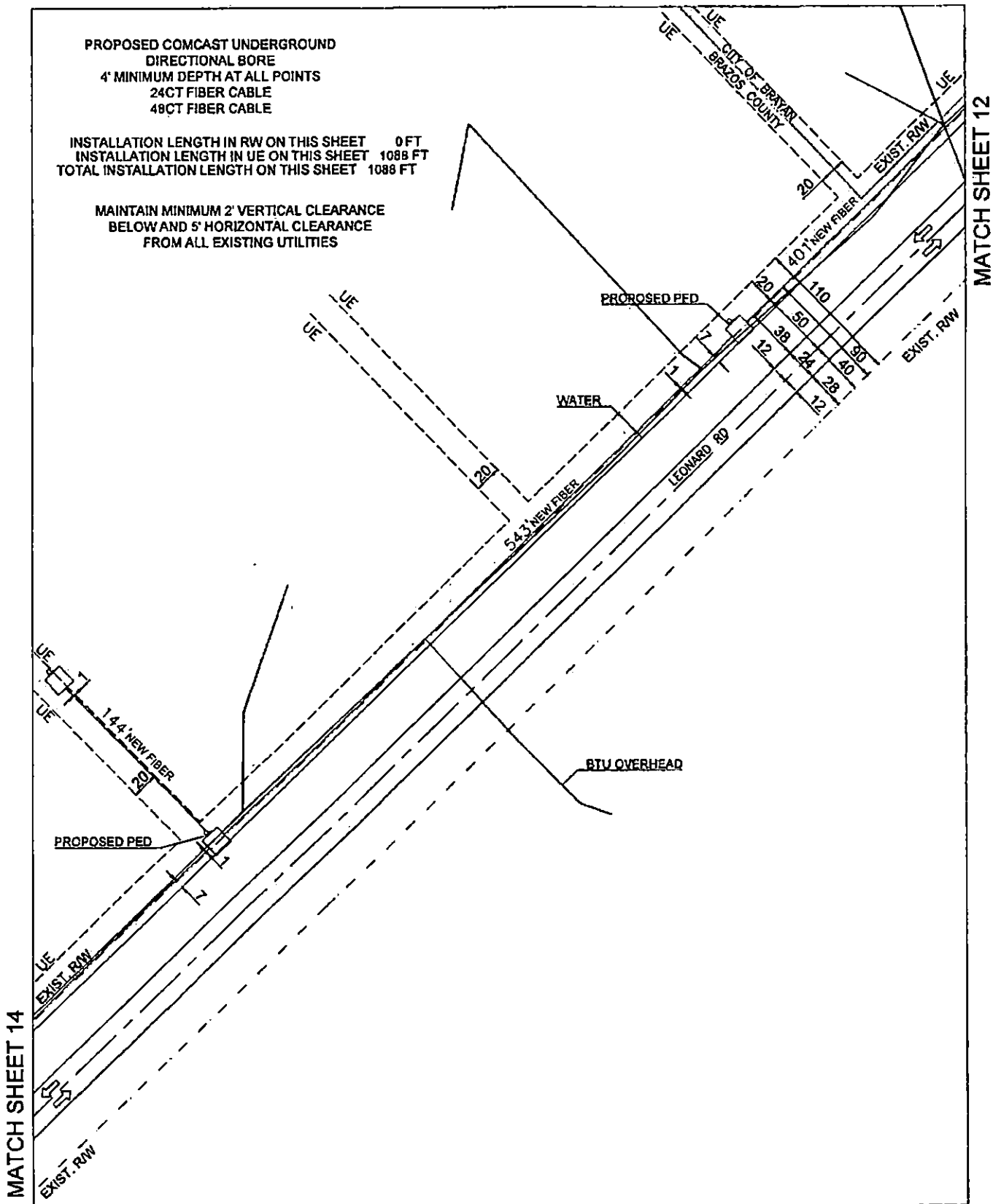

MATCH SHEET 14

MATCH SHEET 12

NO MATCH SHEET

PREPARED BY 	X EXISTING POLE O PROPOSED PEDESTAL V WATER VALVE F FIRE HYDRANT M MANHOLE S S FORM DRAIN	--- RIGHT OF WAY LINE --- TELCO LANE --- WATER LANE --- GAS LANE --- EXISTING ANCHOR --- PROPOSED RISER	--- PROPOSED COAXIAL CABLE --- PROPOSED FIBER CABLE --- PROPOSED DIRECTIONAL BORE --- EXISTING CABLE --- UTILITY EASEMENT --- BTU UNDERGROUND --- BTU OVERHEAD		ENGINEERED FOR BRAZOS COUNTY LEONARD RD TRANSPORT FIBER	NO SCALE SHEET 13 OF 14
	LEGEND RW - RIGHT OF WAY COP - CURB OF PAVEMENT D/W - DRIVEWAY POW - PAVED DRIVEWAY	NOTES BORE HOLE TO BE FILLED SAME DAY VALVE HOLE TO BE FILLED SAME DAY ALL HOLES TO BE TAPPED AND STOPPED				

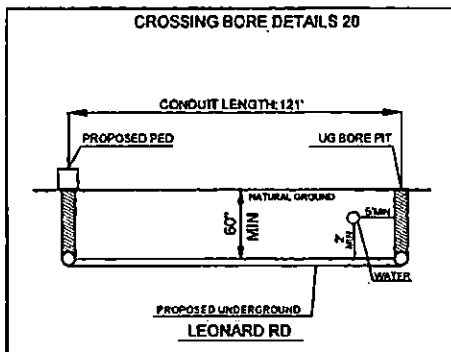
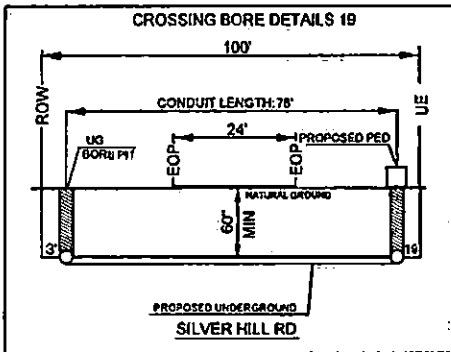
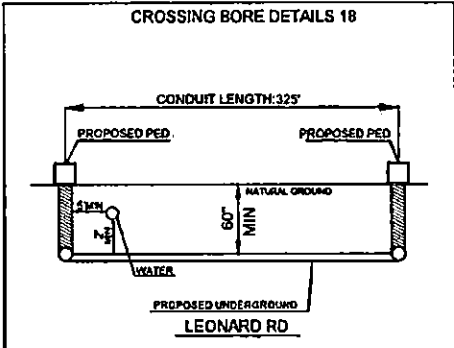
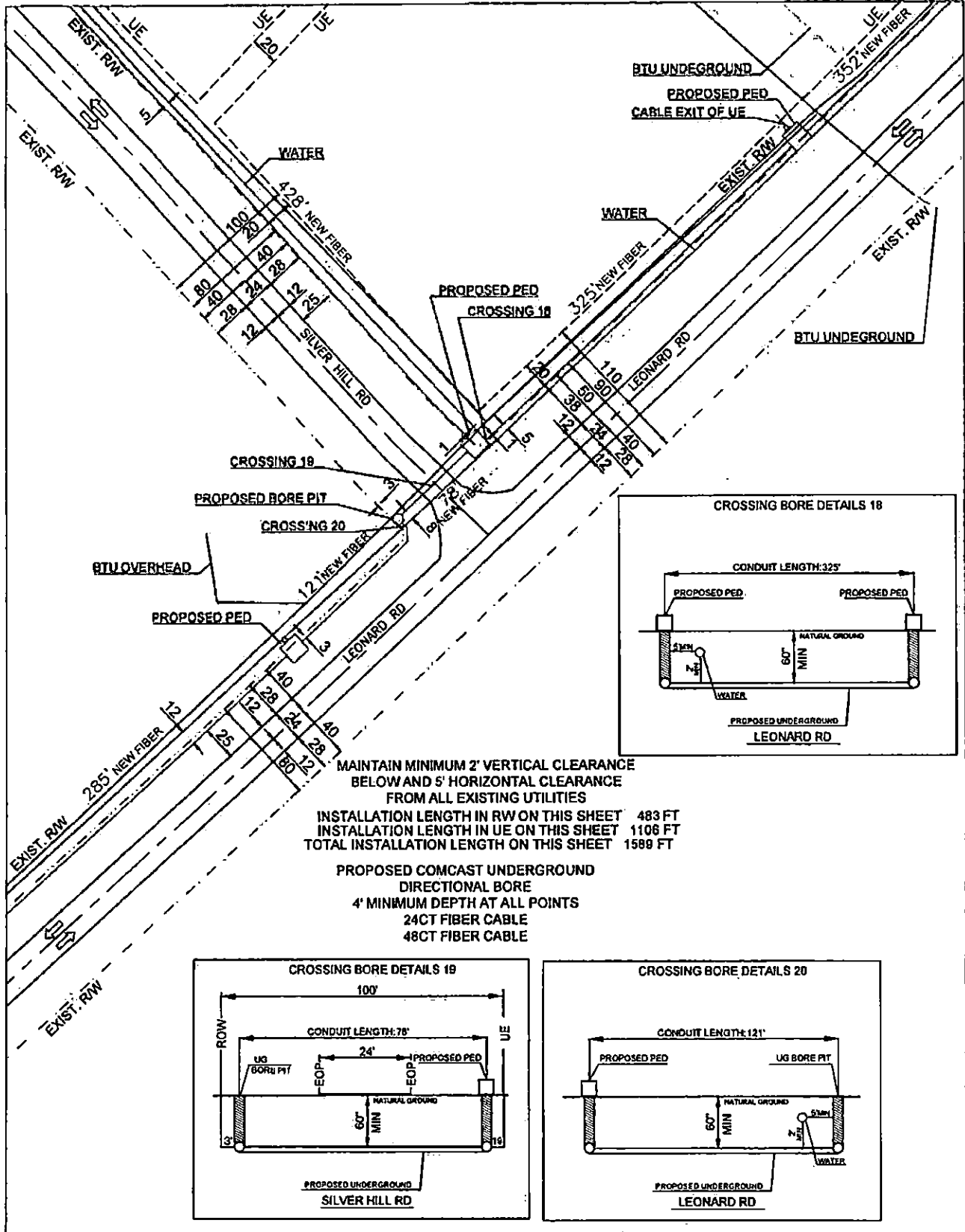

NO MATCH SHEET

<p>PREPARED BY</p>	<p> <input checked="" type="checkbox"/> EXISTING POLE <input checked="" type="checkbox"/> PROPOSED PEDESTAL <input checked="" type="checkbox"/> WATER VALVE <input checked="" type="checkbox"/> FIRE HYDRANT <input checked="" type="checkbox"/> MANHOLE <input checked="" type="checkbox"/> STORM DRAIN </p>	<p> --- RIGHT OF WAY LINE --- TELECOM LANE --- WATER LANE --- GAS LANE --- EXISTING ANCHOR --- PROPOSED RISER </p>	<p> --- PROPOSED COAXIAL CABLE --- PROPOSED FIBER CABLE --- PROPOSED DIRECTIONAL BORE --- EXISTING CABLE --- UTILITY EASEMENT --- BTU UNDERGROUND --- BTU OVERHEAD </p>		<p>ENGINEERED FOR</p> <p style="text-align: center;">COMCAST</p>	<p>BRAZOS COUNTY</p> <p>SILVER HILL RD LEONARD RD TRANSPORT FIBER</p>
<p>QUASAR, INC.</p>	<p> LEGEND: RW - RIGHT OF WAY EOP - EDGE OF PAVEMENT EQ - DRIVEWAY PONT - PAVED DRIVEWAY </p>		<p> NOTES: BORE HOLES TO BE FILLED SAME DAY VALVE HOLES TO BE FILLED SAME DAY ALL HOLES TO BE TAMPED AND EGGED </p>		<p>NO SCALE</p>	<p>SHEET 14 OF 14</p>

NO MATCH SHEET

PROPOSED COMCAST UNDERGROUND
 DIRECTIONAL BORE
 4' MINIMUM DEPTH AT ALL POINTS
 24CT FIBER CABLE
 48CT FIBER CABLE

INSTALLATION LENGTH IN RW ON THIS SHEET 733 FT
 INSTALLATION LENGTH IN UE ON THIS SHEET 0 FT
 TOTAL INSTALLATION LENGTH ON THIS SHEET 733 FT

MAINTAIN MINIMUM 2' VERTICAL CLEARANCE
 BELOW AND 5' HORIZONTAL CLEARANCE
 FROM ALL EXISTING UTILITIES

NO MATCH SHEET

MATCH SHEET 14

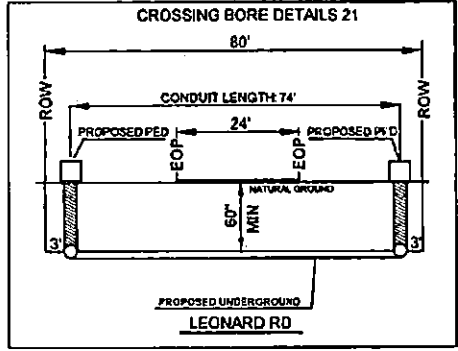
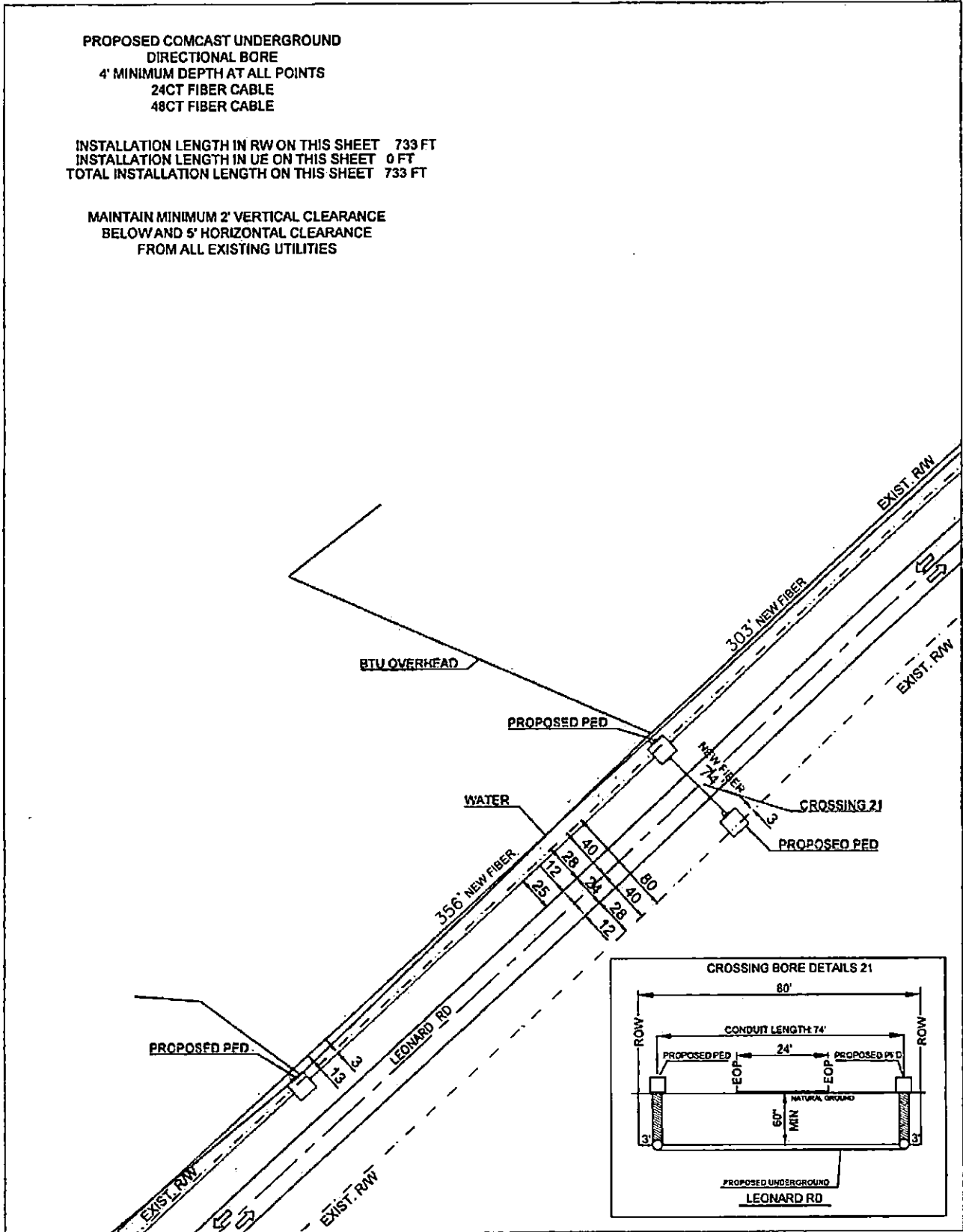

MATCH SHEET 16

PREPARED BY 	EXISTING POLE PROPOSED PEDESTAL WATER VALVE FIRE HYDRANT MANHOLE & FORM DRAIN	RIGHT OF WAY LINE TELECO LANE WATER LANE GAS LANE EXISTING ANCHOR PROPOSED RISER	PROPOSED COAXIAL CABLE PROPOSED FIBER CABLE PROPOSED DIRECTIONAL BORE EXISTING CABLE UTILITY EASEMENT BTU UNDERGROUND BTU OVERHEAD		ENGINEERED FOR 	BRAZOS COUNTY LEONARD RD TRANSPORT FIBER
	LEGEND RW - RIGHT OF WAY EOP - EDGE OF PAVEMENT DR - DRIVEWAY POW - PAVED DRIVEWAY	NOTES: BORE HOLE TO BE FILLED SAME DAY WALK HOLE TO BE FILLED SAME DAY ALL HOLES TO BE TAMPED AND SOODED	NO SCALE SHEET 13 OF 16			

PROPOSED COMCAST UNDERGROUND
DIRECTIONAL BORE
4' MINIMUM DEPTH AT ALL POINTS
24CT FIBER CABLE

INSTALLATION LENGTH IN RW ON THIS SHEET 420 FT
INSTALLATION LENGTH IN UE ON THIS SHEET 0 FT
TOTAL INSTALLATION LENGTH ON THIS SHEET 420 FT

TOTAL INSTALLATION LENGTH 14464 FT
AERIAL: 0 FT

UG: 14464 FT
START 30.627790, -96.441721
END 30.608726, -96.435267

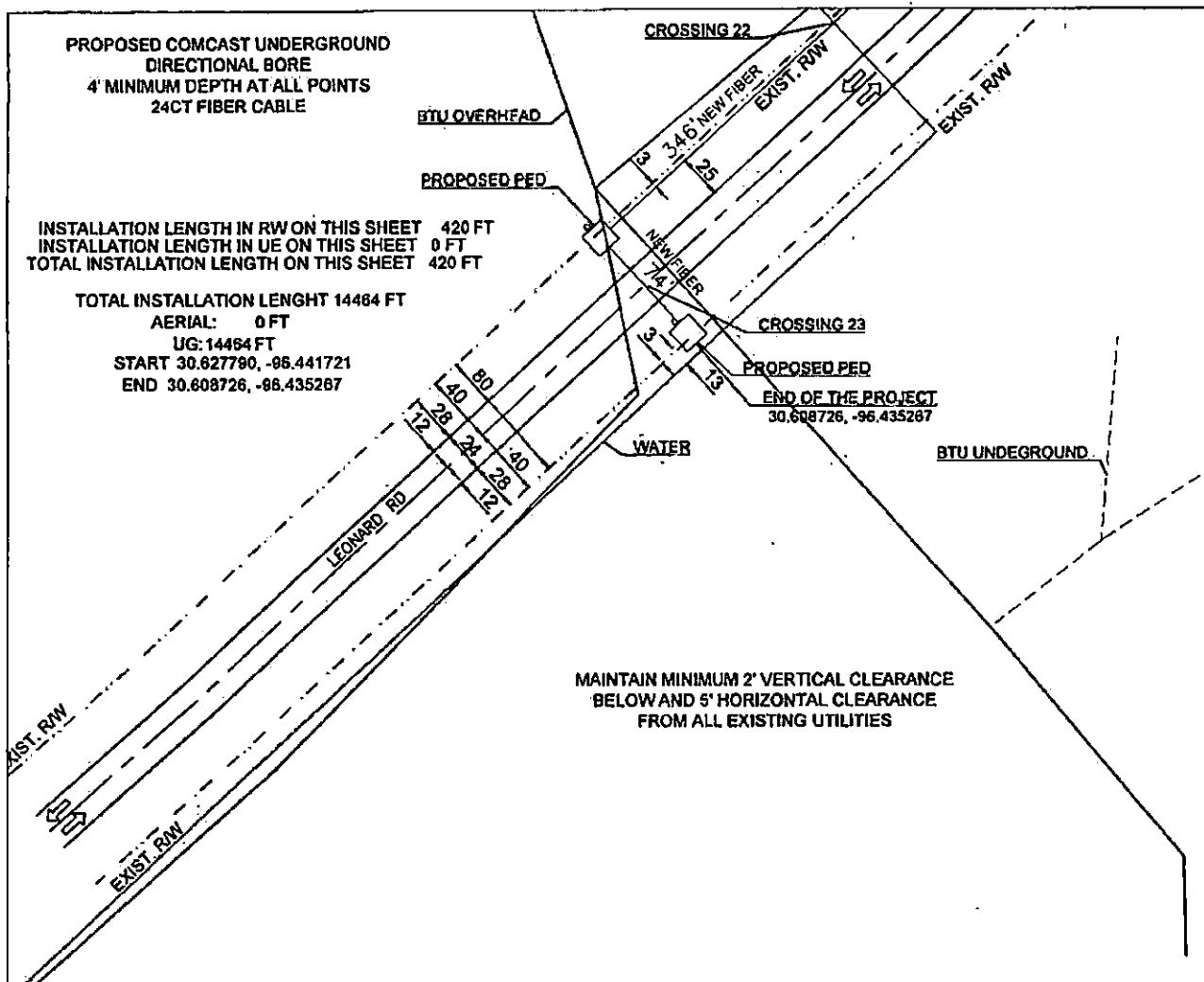

MAINTAIN MINIMUM 2' VERTICAL CLEARANCE
BELOW AND 5' HORIZONTAL CLEARANCE
FROM ALL EXISTING UTILITIES

NO MATCH SHEET

NO MATCH SHEET

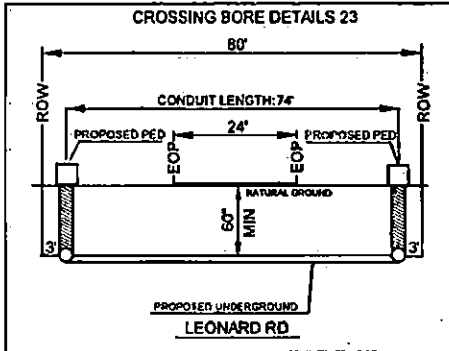
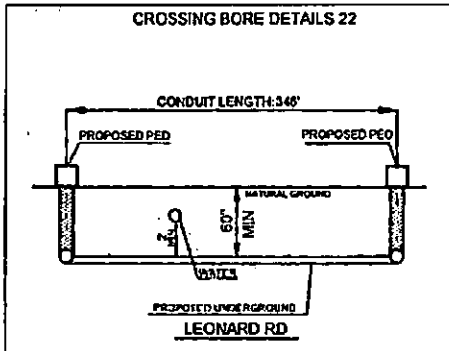

NO MATCH SHEET

PREPARED BY 	EXISTING POLE PROPOSED PEDIestal WATER VALVE FIRE HYDRANT MANHOLE STORM DRAIN	RIGHT OF WAY LINE TELEPHONE LANE WATER LANE GAS LANE EXISTING ANCHOR PROPOSED RISER	PROPOSED COAXIAL CABLE PROPOSED FIBER CABLE PROPOSED DIRECTIONAL BORE EXISTING CABLE UTILITY EASEMENT BTU UNDERGROUND BTU OVERHEAD		ENGINEERED FOR 	BRAZOS COUNTY LEONARD RD TRANSPORT FIBER
	LEGEND RW - RIGHT OF WAY EOP - EDGE OF PAVEMENT DM - DRIVEWAY POM - PAVED DRIVEWAY	NOTES BORE HOLE TO BE FILLED SAME DAY VALVE HOLES TO BE FILLED SAME DAY ALL HOLES TO BE TAMPED AND SLOTTED	NO SCALE SHEET 16 OF 18			

**BRAZOS COUNTY ROADWAY SAFETY AND ROAD
PRESERVATION STANDARDS FOR WORK CONDUCTED IN
BRAZOS COUNTY RIGHTS OF WAY**

A. General Requirements

1. Adequate drainage shall be maintained in ditches at all times.
2. Permittee will use best management practices ("BMP") (EPA and TCEQ both provide lists of examples of BMPs) to minimize erosion and sedimentation resulting from the proposed installation.
3. The permittee shall take precautions to avoid damage to property. All County Right of Way and property shall be restored to its original condition, as far as practical, in the opinion of the County Engineer or appointed representative.
4. The construction and maintenance of such utility shall not interfere with the property or rights of a prior occupant.
5. Permittee shall not interfere with other utilities located in the right of way. In the event damages occur, permittee will be liable to the County or other utilities running through the right of way.
6. County Engineer shall determine whether or not permittee's plans shall inconvenience the public. If it is determined that inconvenience to the public exists, then the County Engineer will decide whether such project will be allowed or if an alternative exists so as not to inconvenience the public.

B. Safety Requirements

1. Proper traffic control measures must be put in place prior to beginning work and remain in place during the duration of the job. All traffic control measures must follow the Texas Manual of Uniform Traffic Control Devices (TMUTCD). See Traffic Control Requirements below.
2. During construction, all safety regulations of the Texas Department of Transportation shall be observed.
3. Permittee must take such precautions and measures, including placing and displaying safety devices, as may be necessary, in order to safely conduct the public through the project area. Company shall provide flagmen, signs, signals or devices necessary to provide complete safety to the public.
4. Adequate provisions must be made to cause minimum inconveniences to traffic and adjacent property owners.
5. No cable, conduit and/or pole line shall be laid, constructed, maintained and/or repaired so as to constitute a danger or hazard of any kind to persons or vehicles using such road. Any poles placed in the Right of Way for future installation shall be placed at the back of the Right of Way. Exceptions may be approved by the County Engineer.

C. Traffic Control Plan

1. A traffic control plan, pursuant to the TMUTCD or Engineered Traffic Control Plan must be provided for the following:
 - a. Any construction (i.e. pit, excavation, hole) left open over night, requires specific nighttime traffic control measures pursuant to the TMUTCD;
 - b. If construction is within ten (10) feet of the roadway; or
 - c. Any work performed in the road right-of-way;

2. Plan must be attached to the permit and kept at the job site any time work is being performed.
3. Plan must set forth the time of completion for the job.

D. Design Standards

1. All overhead installations shall conform to clearance standards of the Texas Department of Transportation and the pole be placed in the designated area for power specified as set forth in the *Texas Utilities Code, Section 181.045*.
2. All pole installation (including lighting) shall be placed at the backside of the Right of Way to ensure safety to the public. Any pole placed in violation of this requirement will be required to be moved to the appropriate location at the company's expense. Exceptions may be approved by the County Engineer.
3. All underground installations shall (these are minimum depths – utility may place deeper):
 - a. be placed at a minimum depth of forty-eight (48) inches below the top of the pavement;
 - b. be at least thirty-six (36) inches below ditch flow line when installation is within the area measured from top of bank to top of bank;
 - c. be at least forty-eight (48) inches below ditch flow line if low pressure gas or petroleum lines. For high pressure gas and petroleum lines, see High Pressure Pipelines requirements listed below;
 - d. not be closer than ten (10) feet from the edge of pavement. Exceptions may apply in rights of way of less than 60'.
4. Water Lines: All water lines must be a minimum 36-inches below the ditch flow line and cased. Waterlines shall be cased if crossing under the roadway.
5. Utilities in all new developments that have 60 feet or greater of right of way shall be installed within designated locations based upon the type of utility. The locations shall be as follows: (measured from back of right-of-way).
 - Power – 0-2 feet, nominally 1'
 - Phone – 2-4 feet, nominally 3'
 - Gas – 4-6 feet, nominally 5'
 - Cable – 6-8 feet, nominally 7'
6. Utilities with less than 60 feet right-of-way in all new developments shall install the utility in a similar manner as referenced in No. 3 above, however, the County Engineer or its designated representative will provide final approval of each utility location.
7. The length of any trench to be opened in advance of the pipe, conduit or ducts may not be longer than 400' if left open over night or unattended.
8. Crossings under a county road shall:
 - a. be bored or jacked. **ABSOLUTELY NO OPEN CUTS WITHIN COUNTY ROAD PAVEMENT;**
 - b. be pressure grouted for the full length of the crossing *if* the annular space between pipe and casing and soil exceeds one (1) inch. Brazos County must be given 24 hours notice of pressure grouting operations and have the opportunity to have an inspector on site to observe pressure grouting operations;
 - c. TxDOT Standard Specification Item 476 shall be followed for all boring, jacking, tunneling and joints.
9. Bore Pits
 - a. no pits shall remain open longer than 2 days;

- b. all pits shall have proper traffic control measures in place. See Traffic Control Plan listed above.
 - c. pits shall NOT be located within ten (10) feet from the edge of pavement without prior approval from the County Engineer or his representative;
 - d. when pits are to remain open for more than 8 hours, due diligence will be used in protecting the spoil pile to prevent drainage problems;
 - e. based upon soil conditions, the County Engineer or his representative may require shoring to protect pavement integrity;
 - f. based upon soil conditions, the County Engineer or his representative may require pits be placed further from the edge of road.
10. Any installation within ten (10) feet of edge of pavement shall meet the following:
- a. location must be approved by the County Engineer or his representative
 - b. backfilled with cement stabilized material.
 - c. based upon soil conditions, the County Engineer or his representative may require shoring to protect pavement integrity.
 - d. All excess water and mud shall be removed from the trench prior to backfilling. Any backfill placed during a rainy period or at other times where excess water cannot be prevented from entering the trench will be considered TEMPORARY and shall be replaced with PERMANENT cement stabilized material as soon as weather permits;
 - e. All disturbed base and pavement materials shall be removed and restored to the satisfaction of the County Engineer or his representatives.
 - f. No side or lateral tamping to fill voids under the base and pavement materials is allowed.
11. Company must be careful to not jeopardize the slope or integrity of the shoulder of the road. In the event Company damages the slope, shoulder or any other portion of the right-of-way, Company will be responsible for repairing the damage and replacing the right-of-way to the condition it was prior to commencing construction.
12. Operation of construction and/or maintenance equipment on the traveled surface of any improved County road will not be permitted, except in an instance whereby the laying, construction, maintenance and/or repair of cables, conduits and/or pole lines cannot be accomplished by any other method and in this event all such equipment shall be of the rubber tire variety. Appropriate traffic control shall be provided meeting TMUTCD requirements.
13. In the event said construction and/or maintenance and/or repair requires Company to remove, cut or jeopardize any section of the road (asphalt, cement, road base, etc), Company will be required to provide a performance bond or letter of credit securing necessary repairs. Said bond amount will be determined by the County Engineer.
14. The applicant shall submit a letter of "No Objection" from the Army Corps of Engineers for all designated wetlands and environmentally sensitive lands.

E. Emergency work

- 1. In the event Company is required to perform emergency services, that requires excavation in a County Right of Way, and unable to notify the County Engineer prior to conducting emergency repairs, Company shall notify County Engineer within 24 hours of beginning construction/repairs. This will allow the County Engineer and Road & Bridge Office an opportunity to inspect the site to ensure the integrity of the County Right of Way and traffic safety controls used.

F. Repairs to existing facilities

1. Maintenance and/or repair to existing cables, conduits, and/or pole lines which require disturbance of the soil, shall not be performed until plans describing such maintenance and/or repair have been approved by the County Engineer or designated representative and a permit has been obtained.

G. Relocation of utilities:

1. When and if the County Engineer determines that it is necessary for the construction, repair, improvement, alteration or relocation of all or any portion of said road, any or all poles, wires, pipes, cables or other facilities and appurtenances authorized hereunder, shall be removed from said road, or reset or relocated thereon, as required by the County Engineer within a reasonable time as determined by the County Engineer and Utility Company, and at the expense of the Utility Company.

H. High Pressure Pipelines

1. All utility Permits for high pressure pipelines (generally 60 PSI or greater), whether pertaining to controlled access or non-controlled access installations, should contain the following additional information in the description of the permit.
 - diameter
 - wall thickness
 - material specification
 - minimum yield strength
 - maximum operation pressure of the pipeline

2. With the exception of the maximum operation pressure of the pipeline, this information is to be supplied for both the carrier pipe and the casing.

3. Assurance must also be given that the installation material and design meet the minimum Federal Safety Standards for Liquid and Gas Pipe Lines. Assurance must be provided on company letterhead and signed by an authorized representative of the company.

4. Petroleum Pipelines:

<u>Type of Pipeline</u>	<u>Depth (below deepest ditch grade)</u>	<u>Special Requirements</u>
Encased Pipe	Less than 10'	Must be covered with concrete pad at least 36" deep
Encased Pipe	Greater than 10'	No concrete pad required
Non-Cased Pipe	Less than 10'	Must be covered with concrete pad at least 48" deep
Non-Cased Pipe	Greater than 10'	No concrete pad required

The Concrete pad shall be minimum of 3" thick and width shall be pipe diameter plus 18" minimum.

5. Under no circumstances will a pipeline be installed parallel to a County Road within the Right-of-Way. Transmission lines have been determined to be petroleum pipelines (which includes natural gas lines) and shall not be parallel to a County Road.

6. Natural Gas Distribution is a line that serves the final customer.

DISCLAIMER: This document is prepared by the Texas Engineering Practice Act. No warranty of any kind is made by TEPAC for any purpose whatsoever. TEPAC assumes no responsibility for the completion of this document or for any consequences that may result from its use.

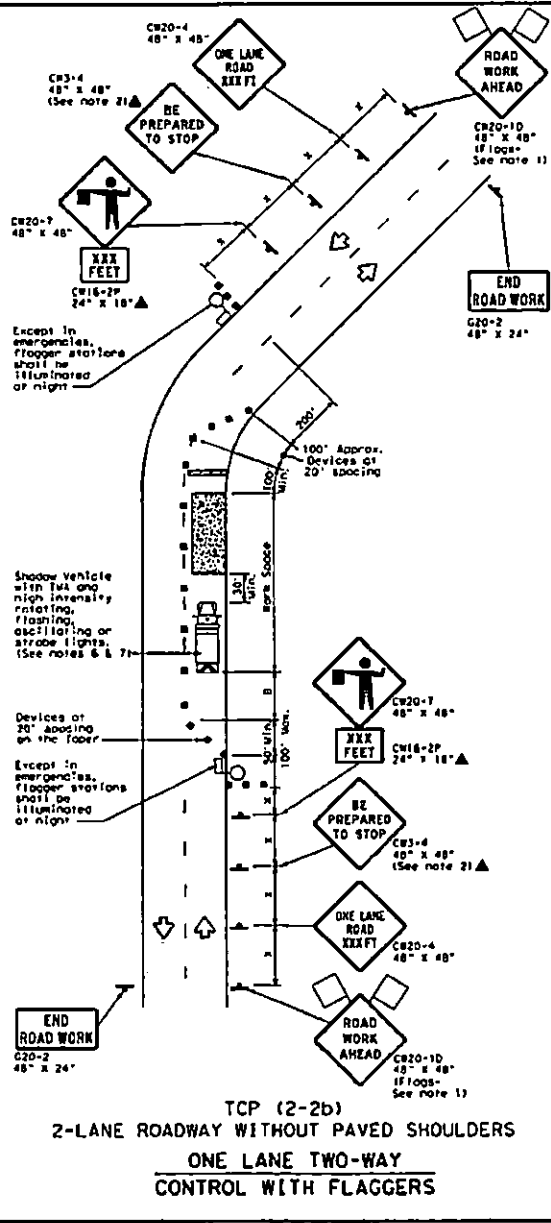
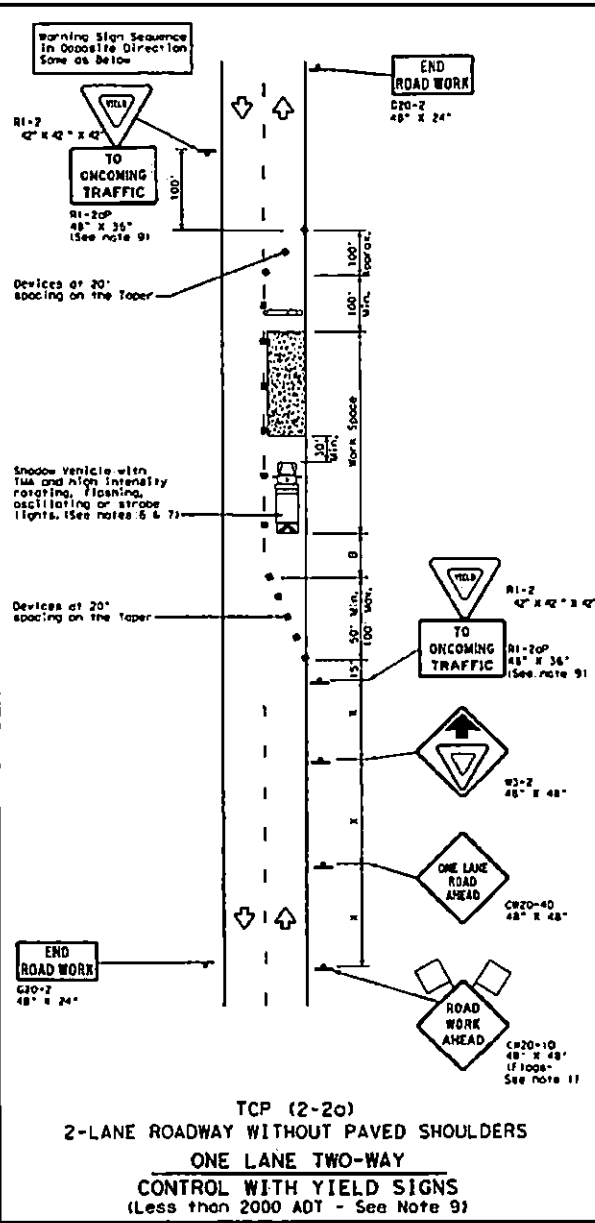

LEGEND

	Type 3 Barricade		Channelizing Devices
	Heavy Work Vehicle		Truck Mounted Attenuator (TMA)
	Trailer Mounted Flashing Arrow Board		Portable Changeable Message Sign (PCMS)
	Sign		Traffic Flow
	Flag		Flagger

Posted Speed #	Formula	Minimum Desirable Taper Lengths M			Suggested Maximum Spacing of Channelizing Devices		Minimum Sign Spacing ft	Suggested Longitudinal Buffer Space ft	Stopping Sight Distance
		10'	11'	12'	On a Taper	On a Taper			
30	L = WS ²	150'	165'	180'	30'	60'	120'	90'	200'
35		205'	225'	245'	35'	70'	160'	120'	250'
40		265'	295'	320'	40'	80'	240'	155'	305'
45		450'	495'	540'	45'	90'	320'	195'	360'
50		300'	330'	360'	50'	100'	400'	240'	425'
55		550'	605'	660'	55'	110'	500'	295'	495'
60		600'	660'	720'	60'	120'	600'	350'	570'
65		650'	715'	780'	65'	130'	700'	410'	645'
70		700'	770'	840'	70'	140'	800'	475'	730'
75		750'	825'	900'	75'	150'	900'	540'	820'

M Conventional Roads Only
 W Taper lengths have been rounded off.
 L Length of Taper (FT) Width of Offsets (FT) S Posted Speed (MPH)

TYPICAL USAGE

MOBILE	SHORT DURATION	SHORT TERM STATIONARY	INTERMEDIATE TERM STATIONARY	LONG TERM STATIONARY

GENERAL NOTES

- Flags attached to signs where shown, are REQUIRED.
- All traffic control devices illustrated are REQUIRED, except those denoted with the triangle symbol may be omitted when stated elsewhere in the plan, or for routine maintenance work, when approved by the Engineer.
- The C20-4 "BE PREPARED TO STOP" sign may be installed after the C20-4 "ONE LANE ROAD AHEAD" sign, but proper sign spacing shall be maintained.
- Flaggers should use two-way radios or other methods of communication to control traffic.
- Length of work space should be based on the ability of flaggers to communicate.
- A Shadow Vehicle with a TMA should be used anytime it can be positioned 30 to 100 feet in advance of the area of crew exposure without adversely affecting the performance or quality of the work. If workers are no longer present but road or work conditions require the traffic control to remain in place, Type 3 Barricades or other channelizing devices may be substituted for the Shadow Vehicle and TMA.
- Additional Shadow Vehicles with TMA may be positioned off the paved surface, near to those shown in order to protect a larger work space.

TCP (2-2a)

- The RI-2 "YIELD" sign traffic control may be used on projects with approaches that have adequate sight distance. For projects in urban areas, work space should be no longer than one half city block. In rural areas, roadways with less than 2000 ADT, work space should be no longer than 400 feet.
- The RI-2P "YIELD TO ONCOMING TRAFFIC" sign shall be placed on a support of a 1 foot minimum mounting height.

TCP (2-2b)

- Channelizing devices on the center line may be omitted when a pilot car is leading traffic and approved by the Engineer.
- If the work space is located near a horizontal or vertical curve, the buffer distances should be increased in order to maintain stopping sight distance to the flagger and a queue of stopped vehicles. (See table above).
- Flaggers should use 24" STOP/SLOW paddles to control traffic. Flags should be limited to emergency situations.

Notes:
 The contractor must notify the precinct at least 48 hours before a lane closure.

No lanes shall be closed during the hours of 7:00 AM to 9:00 AM and 4:00 PM to 6:00 PM Monday through Friday.

Texas Department of Transportation
 Traffic Operations Division Standards

TRAFFIC CONTROL PLAN
ONE-LANE TWO-WAY
TRAFFIC CONTROL

TCP (2-2) - 1B

FILE#	1007-2-1B.dwg	REV	1	DATE	01/12/12
PROJECT	1007-2-1B	DATE	01/12/12	APP	01/12/12
DATE	01-12-12	DATE	01-12-12	DATE	01-12-12
DATE	01-12-12	DATE	01-12-12	DATE	01-12-12



**BRAZOS COUNTY
BRYAN, TEXAS**

DEPARTMENT: Road and Bridge NUMBER: CC-2026-Comcast-Old Spanish Trail-Oak Trail-Spanish Hill-Redbud

DATE OF COURT MEETING: 6/23/2026

ITEM: Consider and take action on the Comcast utility permit to construct road bores under the following County Roads located within Old Spanish Trail Estates and Benchley Oaks Subdivision. Sites are located in Precinct 4.

- a. Old Spanish Trail – 10 crossings
- b. Oak Trail – 3 crossings
- c. Spanish Hill – 2 crossings
- d. Redbud Drive – 1 crossing

TO: Commissioners Court

FROM: Joe Salvato

DATE: 06/02/2026

FISCAL IMPACT: False

BUDGETED: False

DOLLAR AMOUNT: \$0.00

Permit approval is for ROAD BORES ONLY, all other lines, conduits and appurtenances that parallel any roadway MUST be placed within the platted Public Utility Easement (PUE) of Old Spanish Trail Estates and Benchley Oaks Subdivisions

NOTES/EXCEPTIONS: Department requesting agenda item: Road and Bridge
Department impacted by agenda item: Road and Bridge
Brief explanation of agenda item and if in current year budget: Permit allows Comcast to install road bores within right-of-way of following County Roads located in Old Spanish Trail Estates Subdivision: Old Spanish Trail - 10; Oak Trail - 3 and Spanish Hill - 2 and Benchley Oaks Subdivision - Redbud - 1
Brazos County has NO financial responsibility in project.
Consequences for failing to approve agenda item: Less customer choice for internet
Deadline for agenda item approval: As soon as possible
Site of work being performed: Precinct 4 - Old Spanish Trail Estates Subdivision - Old Spanish Trail, Oak Hill and Spanish Hill and Benchley Oaks Subdivision - Redbud Drive

ATTACHMENTS:

File Name

[Utility Permit-Comcast-Old Spanish Trail-Oak Trail-Spanish Hill-Redbud.pdf](#)

Description

Utility Permit-Comcast-Old Spanish Trail Estates-Benchley Oaks

Type

Backup Material

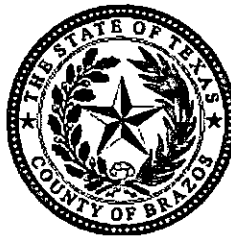

**BRAZOS COUNTY
BRYAN, TEXAS**

DEPARTMENT: Road and Bridge NUMBER: CC-2026-Comcast-Old Spanish Trail-Oak Trail-Spanish Hill-Redbud

DATE OF COURT MEETING: 6/23/2026

ITEM: Consider and take action on the Comcast utility permit to construct road bores under the following County Roads located within Old Spanish Trail Estates and Benchley Oaks Subdivision. Sites are located in Precinct 4.

- a. Old Spanish Trail – 10 crossings
- b. Oak Trail – 3 crossings
- c. Spanish Hill – 2 crossings
- d. Redbud Drive – 1 crossing

TO: Commissioners Court

FROM: Joe Salvato

DATE: 06/02/2026

FISCAL IMPACT: False

BUDGETED: False

DOLLAR AMOUNT: \$0.00

APPROVED



6/23/26
Date

Duane Peters
County Judge

Permit approval is for ROAD BORES ONLY, all other lines, conduits and appurtenances that parallel any roadway MUST be placed within the platted Public Utility Easement (PUE) of Old Spanish Trail Estates and Benchley Oaks Subdivisions

Department requesting agenda item: Road and Bridge
 Department impacted by agenda item: Road and Bridge
 Brief explanation of agenda item and if in current year budget: Permit allows Comcast to install road bores within right-of-way of following County Roads located in Old Spanish Trail Estates Subdivision: Old Spanish Trail - 10; Oak Trail - 3 and Spanish Hill - 2 and Benchley Oaks Subdivision - Redbud - 1
 Brazos County has NO financial responsibility in project.
 Consequences for failing to approve agenda item: Less customer choice for internet
 Deadline for agenda item approval: As soon as possible
 Site of work being performed: Precinct 4 - Old Spanish Trail Estates Subdivision - Old Spanish Trail, Oak Hill and Spanish Hill and Benchley Oaks Subdivision - Redbud Drive

NOTES/EXCEPTIONS:

ATTACHMENTS:

<u>File Name</u>	<u>Description</u>	<u>Type</u>
<u>Utility_Permit-Comcast-Old_Spanish_Trail-Oak_Trail-Spanish_Hill-Redbud.pdf</u>	Utility Permit-Comcast-Old Spanish Trail Estates-Benchley Oaks	Backup Material

**NOTIFICATION OF PROPOSED INSTALLATION AND/OR REPAIRS
OF TELEPHONE FACILITIES AND DESIGNATING
PLACEMENT OF UTILITY IN COUNTY RIGHT OF WAY
TO: THE COUNTY ENGINEER OF BRAZOS COUNTY, TEXAS**

Comes now Comcast of Houston, LLC [company name], hereinafter referred to as "Company" a Texas [state] Corporation, with authority to transact business in Texas, acting by and through its duly authorized representative, and hereby notifies the County Engineer of its intent to lay, construct, maintain, repair and/or operate a telephone facility under, over, across and/or along certain County Roads as shown on drawings and diagrams attached hereto and said location described as follows:

Comcast proposes to install by directional bore a single 2-inch SDR-11 HDPE conduit under the following County Roads within Old Spanish Trail Estates and Benchley Oaks Subdivisions:

Old Spanish Trail – 10 crossings
Oak Trail – 3 crossings
Spanish Hill – 2 crossings
Redbud Drive – 1 crossing

Project includes the installation of 24/48-count fiber optic cable at a minimum depth of 4-feet at all points and a minimum of 5-feet under roadways, along with associated pedestals in the platted subdivision PUE

The location and description of the proposed installation and appurtenances must be fully shown on detailed drawings attached to this Notification.

The Company shall commence actual construction/work in good faith within 60 days from the date of said permit and shall complete said construction /work within 10 working days. (COMPANY MUST FILL IN). If such construction is not begun by the 60th day, Company will be required to provide a new notice.

Company declares that prior to filing this application, it has ascertained the location of all existing utilities, both aerial and underground, and the filing of this application is prima facie evidence that the proposed installation will not conflict with any existing utility.

A copy of this notice shall be kept at the job site any time work is being performed.

In the event of deviation from this notice, the Brazos County Engineer's Office or its designated representative will be notified as soon as practicable.

Approval of County Engineer's Office may take as long as two weeks after complete application is received.

Failure to notify the County Engineer's Office within 24 hours of beginning construction shall constitute grounds for job shutdown.

By signing below, I certify that I am authorized to represent the Company listed below, and that the Company agrees to the conditions/provisions included in this notification.

Comcast of Houston LLC

Company Name

Justin Valentine

By:

Justin Valentine

Signature

Planning & Design Manager

Title

8590 West Tidwell Rd, Houston, Tx, 77040

Address

Phone Number 281-889-5413

Email:

dwenta@quasar.us
Justin_Valentine@comcast.com
shaneitra_jones@comcast.com
Ryan_Hawkins@comcast.com
kpiszczek@quasar.us

ACCEPTANCE OF NOTIFICATION

Brazos County offers no objection to the proposed location of the utility in the County right of way as shown by accompanying drawings and notice dated June 3, 2026 except as noted below:

EXCEPTIONS: Permit is for ROAD BORES ONLY, all other lines, conduits and appurtenances that parallel any roadway MUST be placed within the platted subdivision Public Utility Easement (PUE) of Old Spanish Trail Estates and Benchley Oaks Subdivision

FOR  _____
Brazos County Engineer



WORK AREA
START: 30.738050, -96.462496
END: 30.726355, -96.458801

PREPARED BY:



QUASAR, INC.

COMCAST IS BORING AND INSTALLING NEW CONDUIT
 WITHIN THE RIGHT-OF-WAY AND UTILITY EASMENT
 OWNED BY THE BRAZOS COUNTY.
 TOTAL: 14473ft

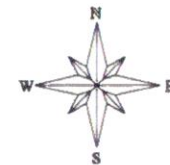

ENGINEERED FOR:



NO SCALE

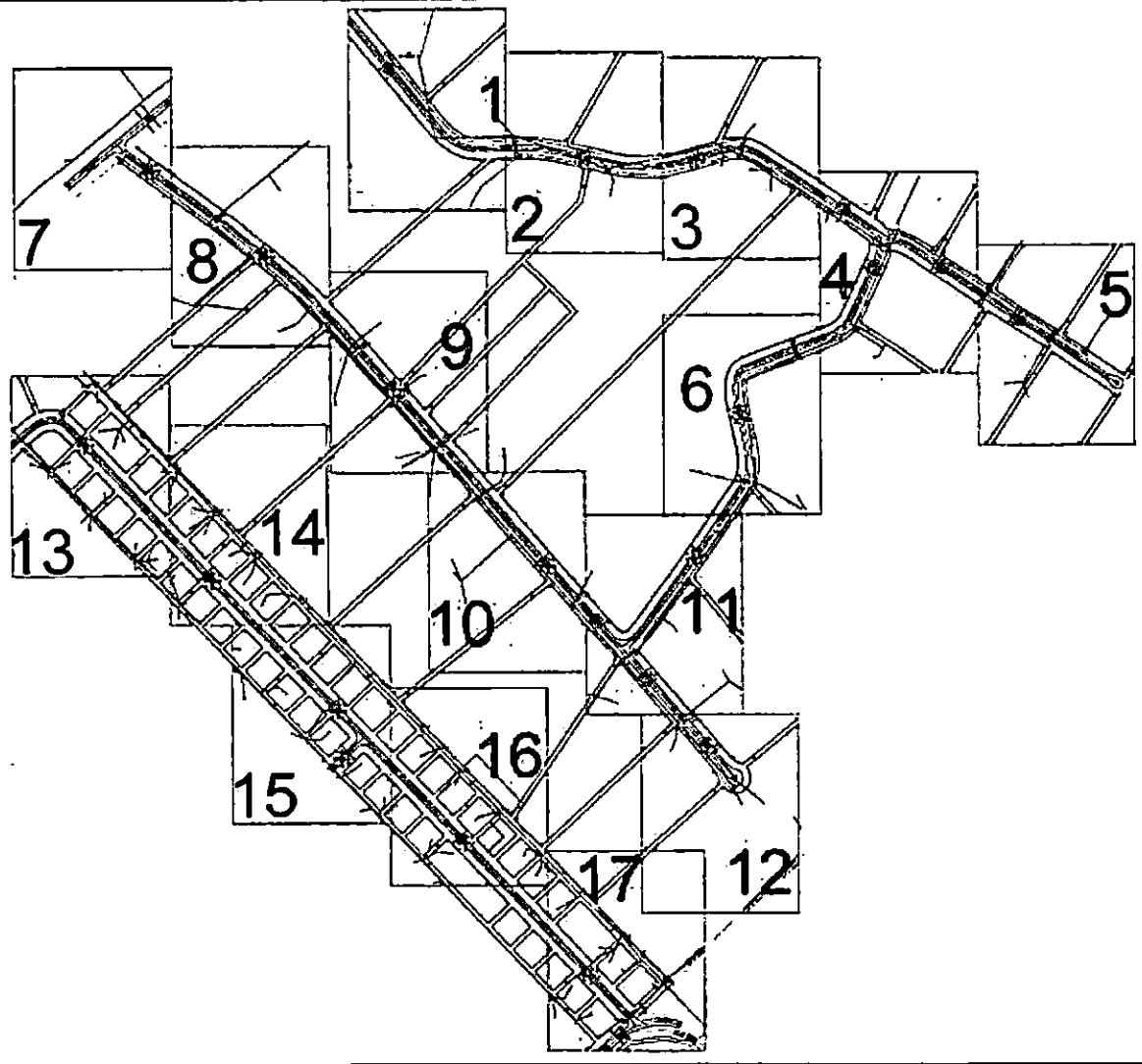

PREPARED BY:



QUASAR, INC.

COMCAST IS BORING AND INSTALLING NEW CONDUIT
 WITHIN THE RIGHT-OF-WAY AND UTILITY EASMENT
 OWNED BY THE BRAZOS COUNTY.
 TOTAL: 14473ft

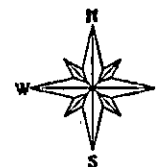

ENGINEERED FOR:



NO SCALE

NO MATCH SHEET

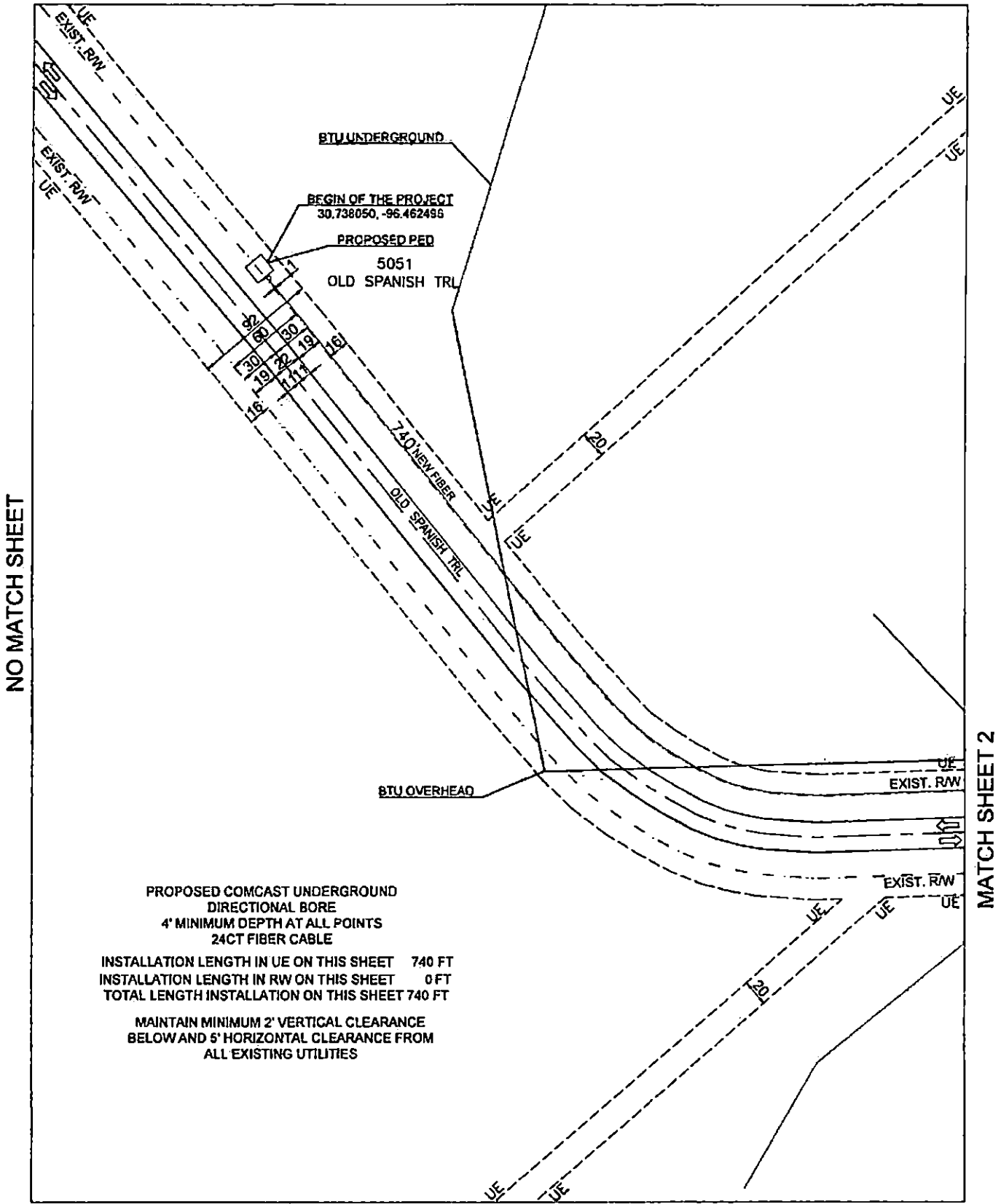

NO MATCH SHEET

MATCH SHEET 2

PROPOSED COMCAST UNDERGROUND
 DIRECTIONAL BORE
 4' MINIMUM DEPTH AT ALL POINTS
 24CT FIBER CABLE

INSTALLATION LENGTH IN UE ON THIS SHEET 740 FT
 INSTALLATION LENGTH IN RW ON THIS SHEET 0 FT
 TOTAL LENGTH INSTALLATION ON THIS SHEET 740 FT

MAINTAIN MINIMUM 2' VERTICAL CLEARANCE
 BELOW AND 5' HORIZONTAL CLEARANCE FROM
 ALL EXISTING UTILITIES

NO MATCH SHEET

PREPARED BY 	EXISTING POLE PROPOSED PEDestal WATER VALVE FIBER MARKER GAS MARKER MANHOLE REVEAL MANHOLE STORM DRAIN	RIGHT OF WAY LINE UTILITY EASEMENT TELECO LINE WATER LINE GAS LINE BTU UNDERGROUND BTU OVERHEAD	PROPOSED COAXIAL CABLE PROPOSED FIBER CABLE PROPOSED DIRECTIONAL BORE EXISTING CABLE		ENGINEERED FOR 	BRAZOS COUNTY OLD SPANISH TRL TRANSPORT FIBER
	LEGEND RW - RIGHT OF WAY COP - EDGE OF PAVEMENT DWP - DRIVEWAY PDW - PAVED DRIVEWAY	NOTES BORE HOLE TO BE FILLED SAME DAY VAULT HOLE TO BE FILLED SAME DAY ALL HOLE TO BE TAMPED AND BODDED	NO SCALE SHEET 1 OF 11			

NO MATCH SHEET

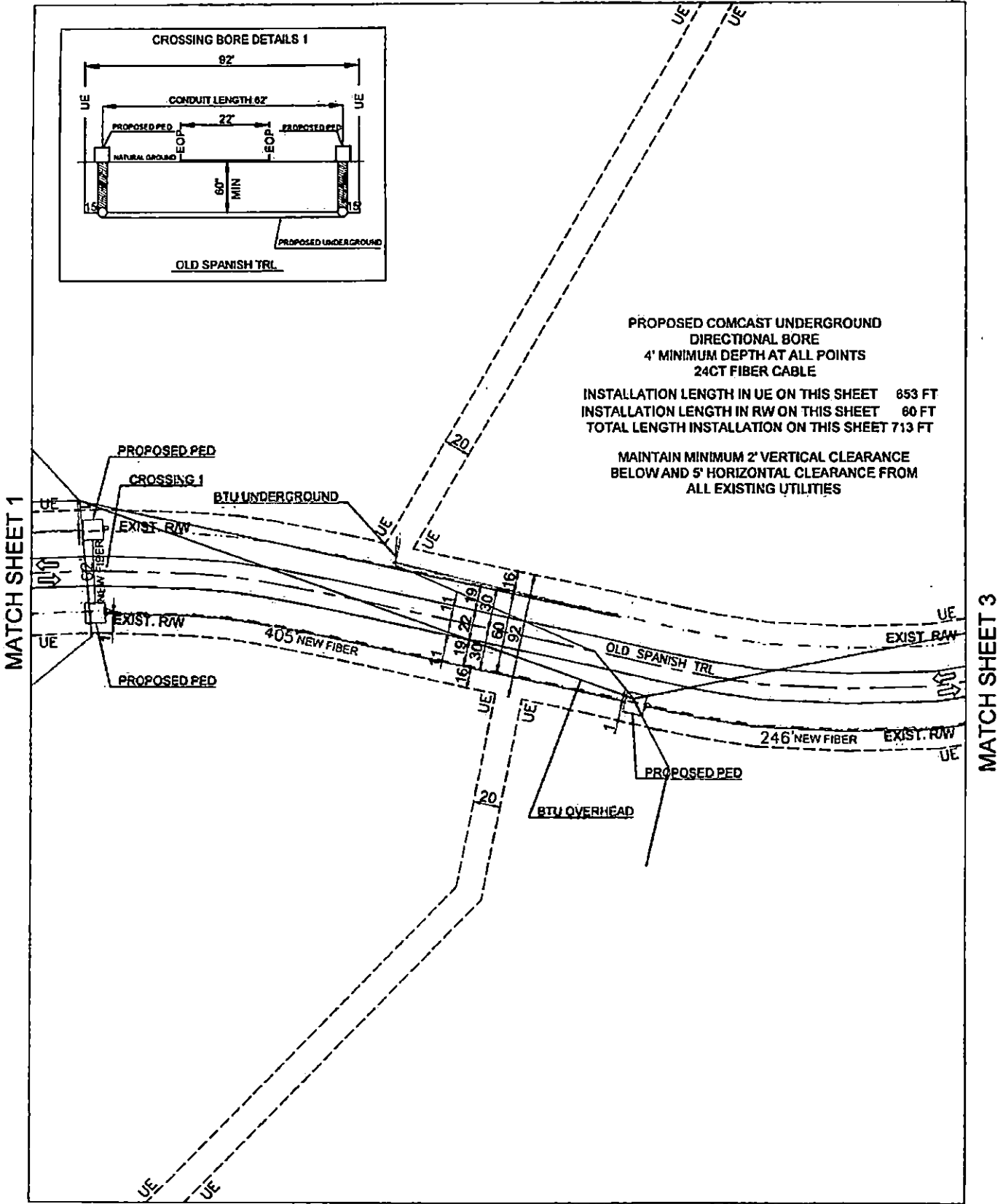

PROPOSED COMCAST UNDERGROUND DIRECTIONAL BORE
 4' MINIMUM DEPTH AT ALL POINTS
 24CT FIBER CABLE

INSTALLATION LENGTH IN UE ON THIS SHEET 653 FT
 INSTALLATION LENGTH IN RW ON THIS SHEET 60 FT
 TOTAL LENGTH INSTALLATION ON THIS SHEET 713 FT

MAINTAIN MINIMUM 2' VERTICAL CLEARANCE BELOW AND 5' HORIZONTAL CLEARANCE FROM ALL EXISTING UTILITIES

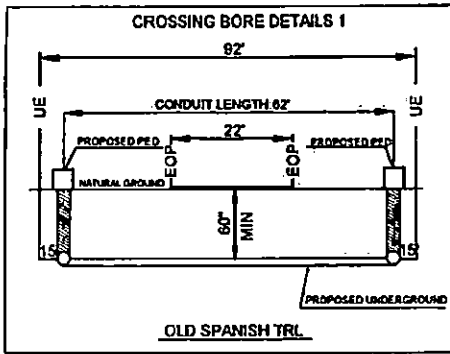

MATCH SHEET 1

MATCH SHEET 3

NO MATCH SHEET

PREPARED BY: 	EXISTING POLE PROPOSED PEDESTAL WATER VALVE FIBER MARKER GAS MARKER MANHOLE SEWER MANHOLE STORM DRAIN	RIGHT OF WAY LINE UTILITY EASMENT TELCO LINE WATER LINE GAS LINE BTU UNDERGROUND BTU OVERHEAD	PROPOSED COAXIAL CABLE PROPOSED FIBER CABLE PROPOSED DIRECTIONAL BORE EXISTING CABLE		ENGINEERED FOR 	GRAZOS COUNTY OLD SPANISH TRL TRANSPORT FIBER
	LEGEND: TOP - POINT OF HWY TOP - EDGE OF PAVEMENT DASH - DRIVEWAY DASH - PAVED DRIVEWAY	NOTES: CONE HOLE TO BE FILLED SAME DAY HOLE TO BE FILLED SAME DAY ALL HOLE TO BE TAMPED AND SMOOTHED	NO SCALE SHEET 2 OF 17			

NO MATCH SHEET

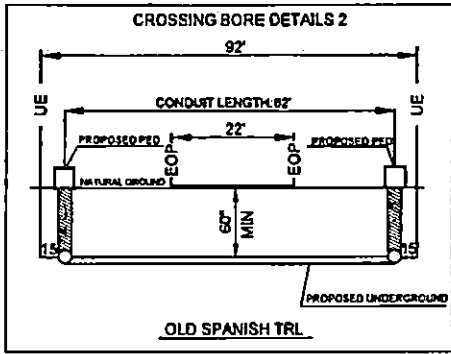

PROPOSED COMCAST UNDERGROUND DIRECTIONAL BORE
 4' MINIMUM DEPTH AT ALL POINTS
 24CT FIBER CABLE
 48CT FIBER CABLE

INSTALLATION LENGTH IN UE ON THIS SHEET 814 FT
 INSTALLATION LENGTH IN RW ON THIS SHEET 60 FT
 TOTAL LENGTH INSTALLATION ON THIS SHEET 874 FT

MAINTAIN MINIMUM 2' VERTICAL CLEARANCE BELOW AND 5' HORIZONTAL CLEARANCE FROM ALL EXISTING UTILITIES

MATCH SHEET 2

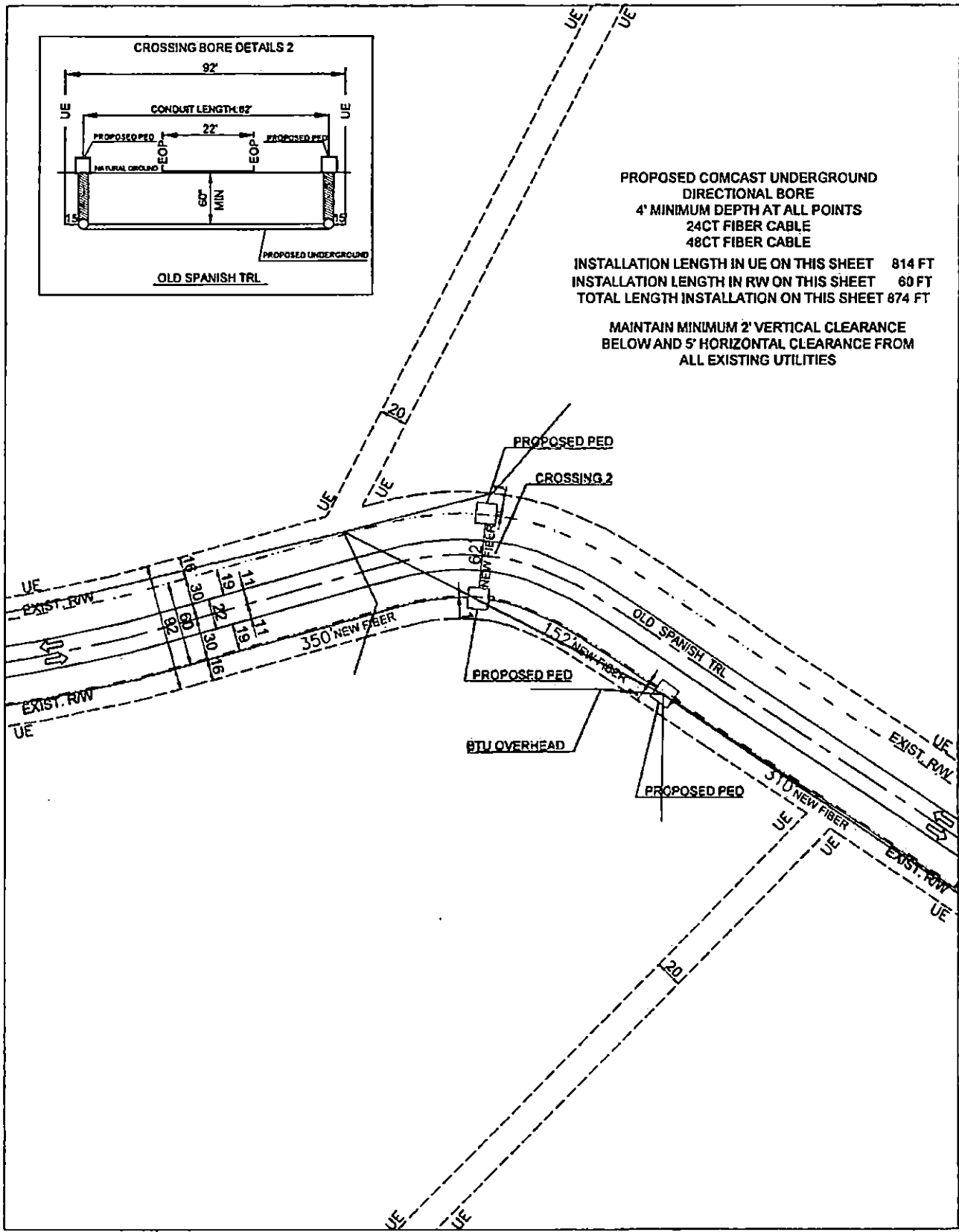

MATCH SHEET 4

NO MATCH SHEET

PREPARED BY 	EXISTING POLE PROPOSED PIEDestal WATER VALVE FIBER MARKER GAS MARKER MANHOLE SEWER MANHOLE STORM DRAIN	RIGHT OF WAY LINE UTILITY EASEMENT TELCO LINE WATER LINE GAS LINE BTU UNDERGROUND BTU OVERHEAD	PROPOSED COAXIAL CABLE PROPOSED FIBER CABLE PROPOSED DIRECTIONAL BORE EXISTING CABLE		ENGINEERED FOR 	BRAZOS COUNTY OLD SPANISH TRL TRANSPORT FIBER
	LEGEND: RW - RIGHT OF WAY EOP - EDGE OF PAVEMENT DRY - DRIVEWAY POW - PAVED DRIVEWAY	NOTES: BORE HOLES TO BE FILLED SAME DAY VAULT HOLES TO BE FILLED SAME DAY ALL HOLES TO BE TAMPED AND BODDED	NO SCALE SHEET 3 OF 11			

NO MATCH SHEET

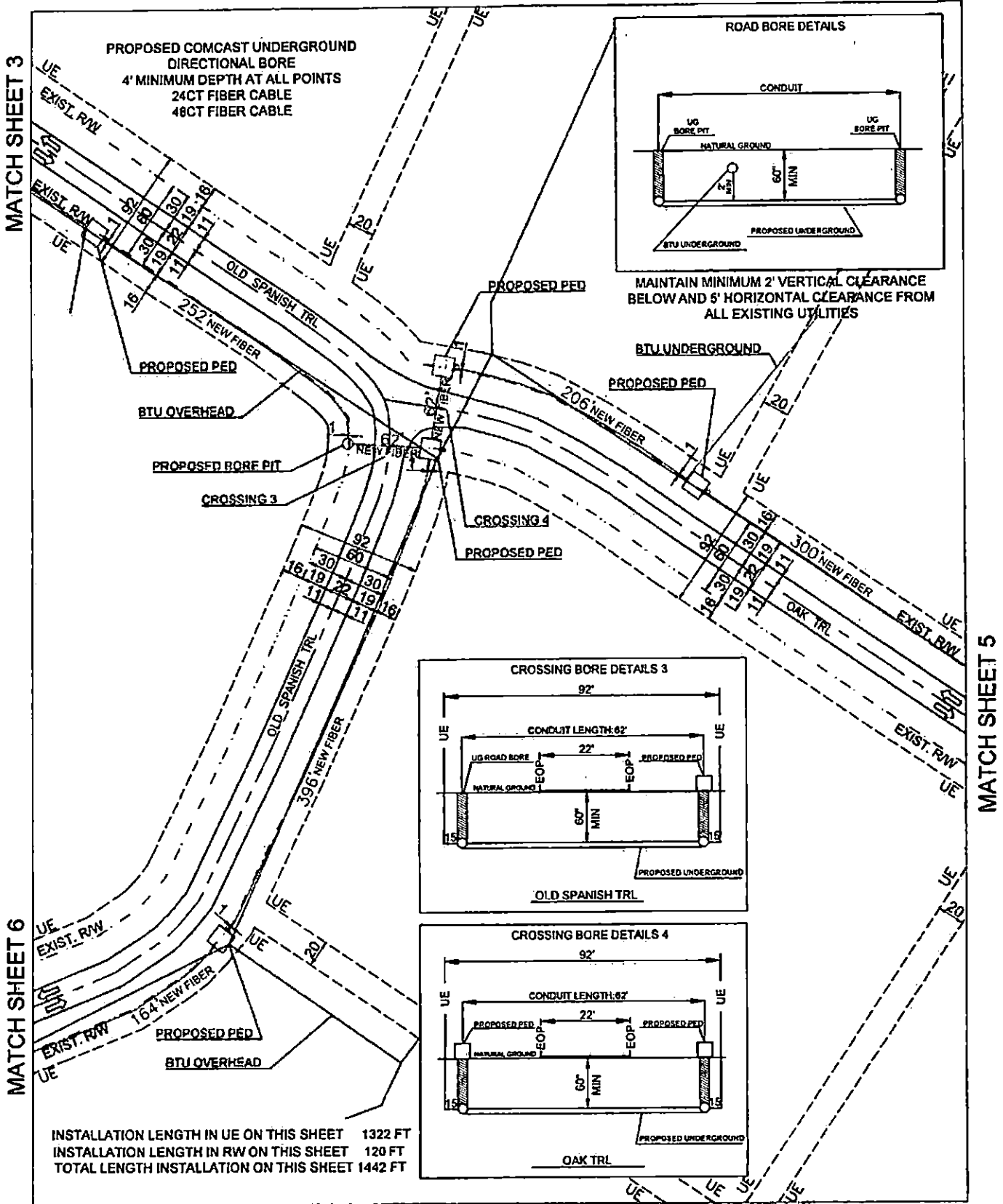

INSTALLATION LENGTH IN UE ON THIS SHEET 1322 FT
 INSTALLATION LENGTH IN RW ON THIS SHEET 120 FT
 TOTAL LENGTH INSTALLATION ON THIS SHEET 1442 FT

NO MATCH SHEET

PREPARED BY: 	X ⊗ ⊗ EXISTING POLE □ PROPOSED PEDESTAL ○ WATER VALVE ⊕ FIBER MARKER ⊙ CAR MARKER ⊕ MAN-HOLE ⊕ SEWER MANHOLE ⊕ STORM GRAB	--- RIGHT OF WAY LINE --- UTILITY EASEMENT --- TELCO LINE --- WATER LINE --- GAS LINE --- BTU UNDERGROUND --- BTU OVERHEAD --- LEGEND --- RW - RIGHT OF WAY --- EOP - EDGE OF PAVEMENT --- ON - OPENLY --- PAV - PAVED DRIVEWAY	--- PROPOSED COAXIAL CABLE --- PROPOSED FIBER CABLE --- PROPOSED DIRECTIONAL BORE --- EXISTING CABLE		ENGINEERED FOR 	BRAZOS COUNTY OLD SPANISH TRL OAK TRL TRANSPORT FIBER
	NOTES: BORE HOLE TO BE FILLED SAME DAY VALVE HOLE TO BE FILLED SAME DAY ALL HOLE TO BE TAMPED AND SODDED				NO SCALE SHEET 4 OF 11	

NO MATCH SHEET

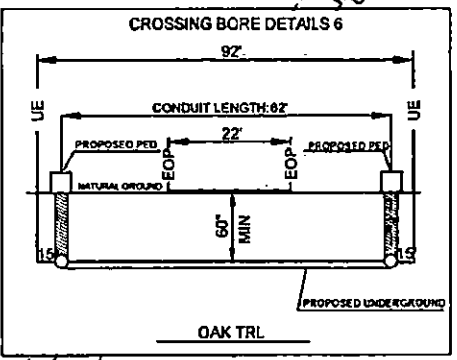
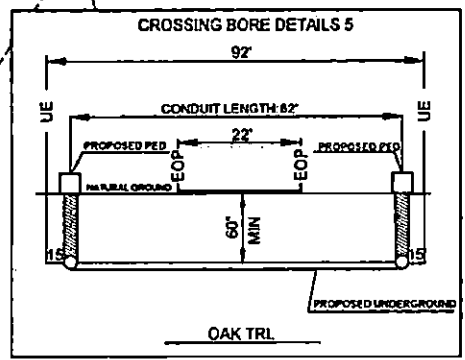
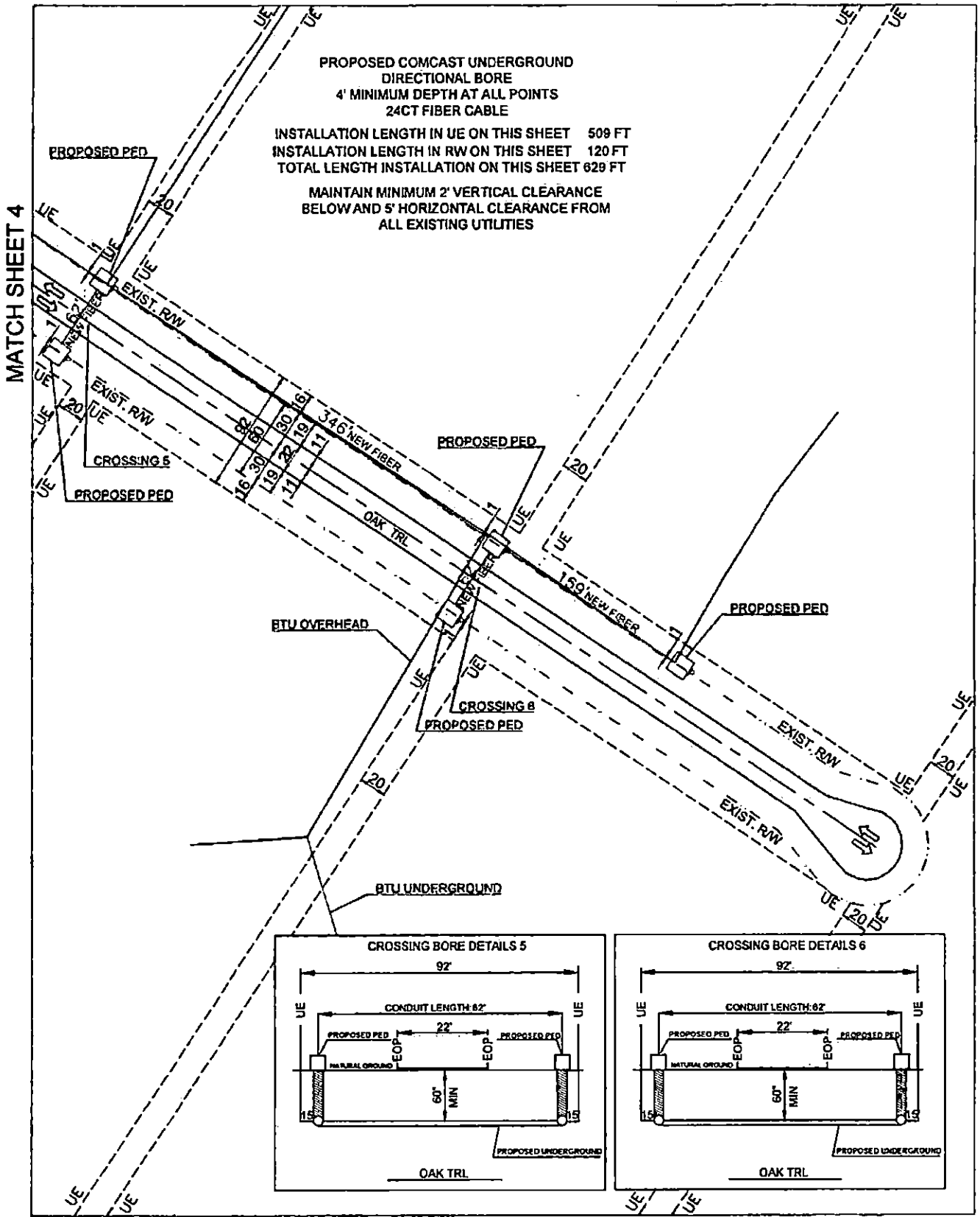

NO MATCH SHEET

PREPARED BY 	EXISTING POLE PROPOSED PEDESTAL WATER VALVE FIBER MARKER GAS MARKER MANHOLE REVERING MANHOLE STORM DRAIN	RIGHT OF WAY LINE UTILITY EASEMENT YELLOW LINE WATER LINE GAS LINE BTU UNDERGROUND BTU OVERHEAD	PROPOSED COAXIAL CABLE PROPOSED FIBER CABLE PROPOSED DIRECTIONAL BORE EXISTING CABLE		ENGINEERED FOR 	BRAZOS COUNTY OAK TRL TRANSPORT FIBER
	LEGEND RW - RIGHT OF WAY EOP - EDGE OF PAVEMENT DM - DRIVEWAY POW - PAVED DRIVEWAY				NOTES: BORE HOLE TO BE FILLED SAME DAY VAULT HOLE TO BE FILLED SAME DAY ALL HOLE TO BE TAMPED AND BODDED	NO SCALE SHEET 6 OF 17

NO MATCH SHEET

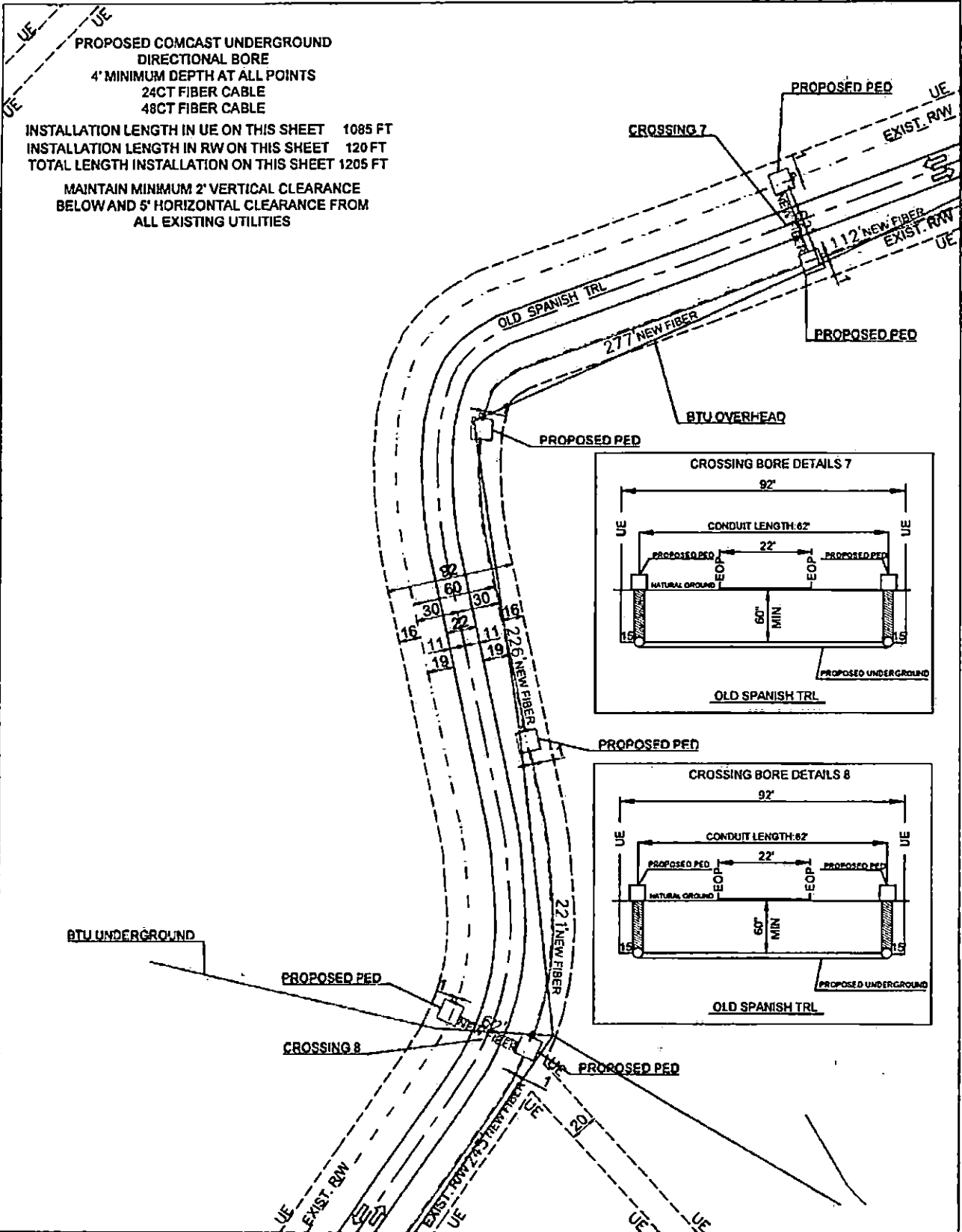

NO MATCH SHEET

MATCH SHEET 4

PROPOSED COMCAST UNDERGROUND
 DIRECTIONAL BORE
 4" MINIMUM DEPTH AT ALL POINTS
 24CT FIBER CABLE
 48CT FIBER CABLE
 INSTALLATION LENGTH IN UE ON THIS SHEET 1085 FT
 INSTALLATION LENGTH IN RW ON THIS SHEET 120 FT
 TOTAL LENGTH INSTALLATION ON THIS SHEET 1205 FT
 MAINTAIN MINIMUM 2' VERTICAL CLEARANCE
 BELOW AND 5' HORIZONTAL CLEARANCE FROM
 ALL EXISTING UTILITIES

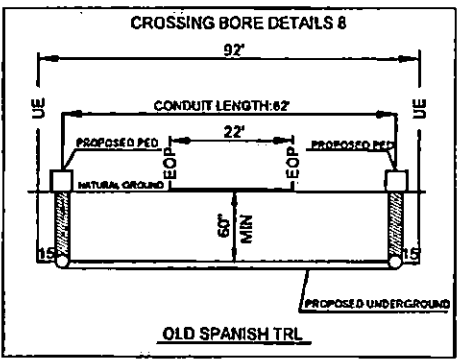
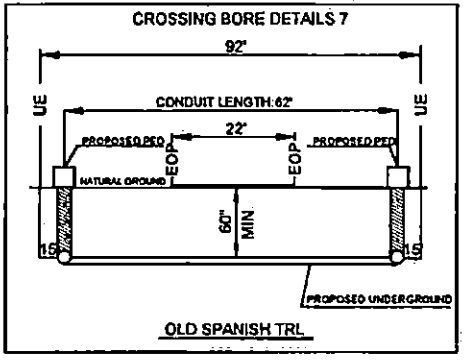

MATCH SHEET 11

PREPARED BY: 	EXISTING POLE PROPOSED PDE & BAL WATER VALVE FIBER MARKER GAS MARKER MANHOLE SEWER MANHOLE STORM DRAIN	RIGHT OF WAY LINE UTILITY EASEMENT TIE/GO LINE WATER LINE GAS LINE BTU UNDERGROUND BTU OVERHEAD	PROPOSED COAXIAL CABLE PROPOSED FIBER CABLE PROPOSED DIRECTIONAL BORE EXISTING CABLE		ENGINEERED FOR 	BRAZOS COUNTY OLD SPANISH TRL TRANSPORT FIBER
	LEGEND RW - RIGHT OF WAY EOP - EDGE OF PAVEMENT DW - DRIVEWAY PDW - PAVED DRIVEWAY	NOTE: BORE HOLE TO BE FILLED SAME DAY WALK HOLE TO BE FILLED SAME DAY ALL HOLE TO BE TAMPED AND SOODED	NO SCALE SHEET 8 OF 17			

NO MATCH SHEET

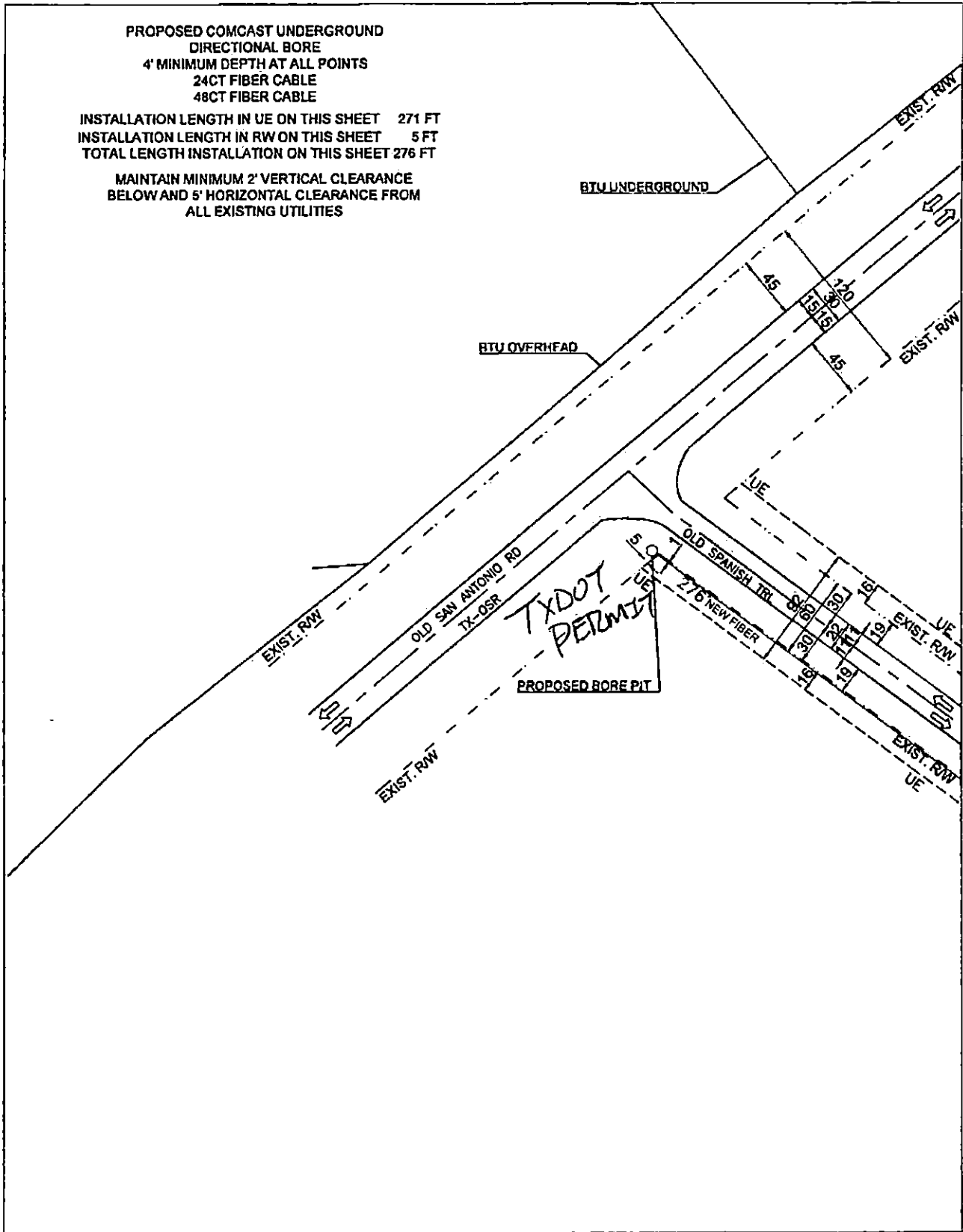

NO MATCH SHEET

MATCH SHEET 8

NO MATCH SHEET

PREPARED BY: 	EXISTING POLE PROPOSED PEDESTAL WATER VALVE FIBER MARKER GAS MARKER MANHOLE SEWER MANHOLE STORM DRAIN	RIGHT OF WAY LINE UTILITY EASEMENT TELCO LINE WATER LINE GAS LINE BTU UNDERGROUND BTU OVERHEAD	PROPOSED COAXIAL CABLE PROPOSED FIBER CABLE PROPOSED DIRECTIONAL BORE EXISTING CABLE		ENGINEERED FOR 	BRAZOS COUNTY OLD SPANISH TRL TRANSPORT FIBER
	LEGEND RW - RIGHT OF WAY EOP - EDGE OF PAVEMENT DW - DRIVEWAY POW - PAVED DRIVEWAY	NOTES BORE HOLE TO BE FILLED SAME DAY VALVE HOLE TO BE FILLED SAME DAY ALL HOLE TO BE TAMPED AND SOODED	NO SCALE SHEET 1 OF 17			

NO MATCH SHEET

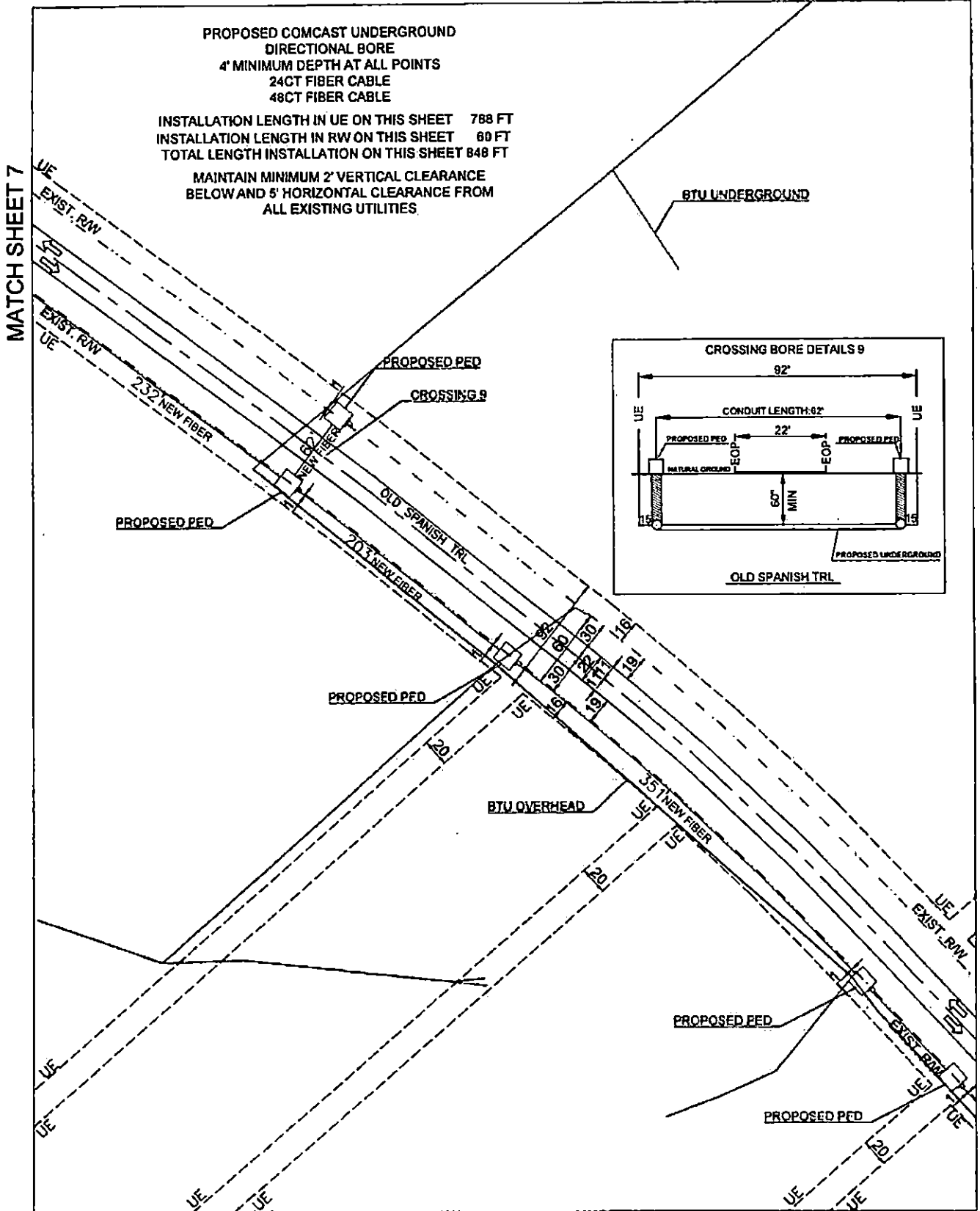

NO MATCH SHEET

PREPARED BY 					ENGINEERED FOR 	BRAZOS COUNTY OLD SPANISH TRL TRANSPORT FIBER
	LEGEND RW - RIGHT OF WAY EOP - FACE OF PAVEMENT DRY DRIVEWAY PDM - PAVED DRIVEWAY	NOTES BORE HOLE TO BE FILLED SAME DAY WALK HOLE TO BE FILLED SAME DAY ALL HOLE TO BE TAMPED AND BODDED	NO SCALE		SHEET 8 OF 17	

NO MATCH SHEET

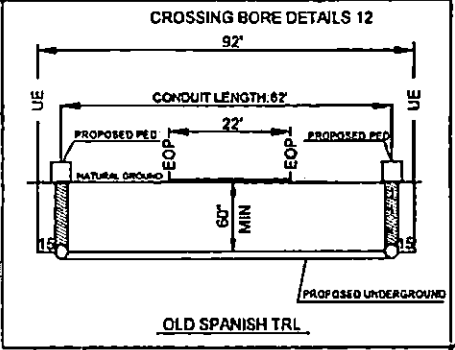
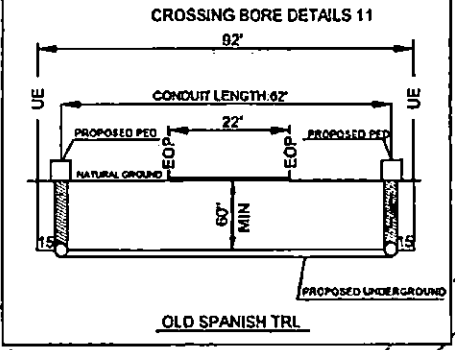
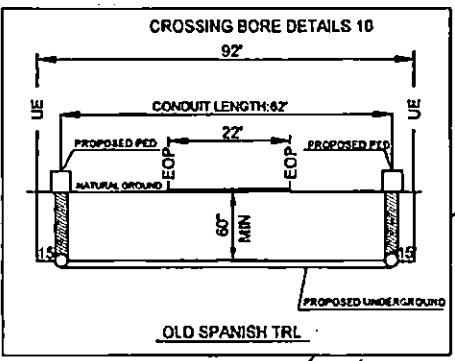
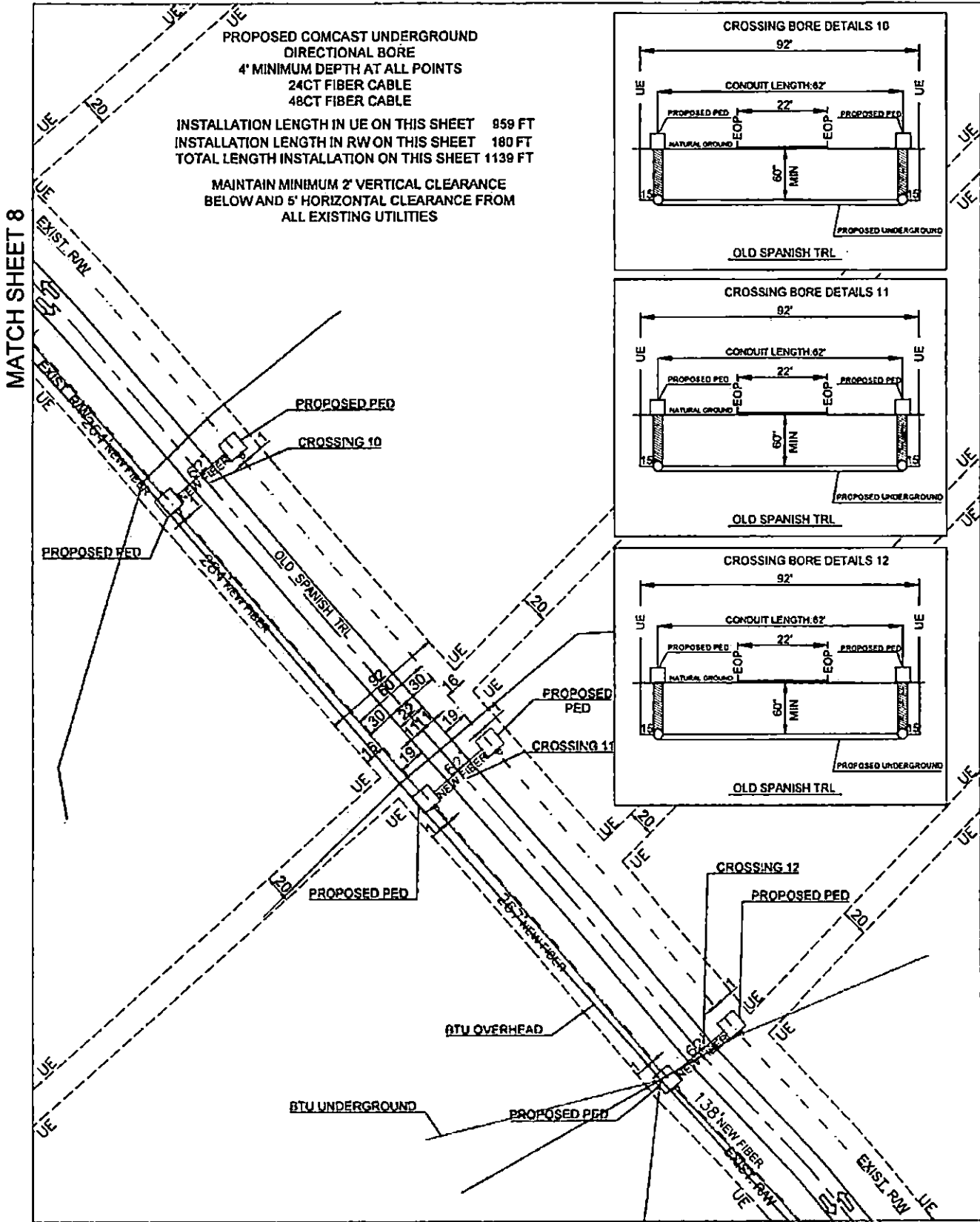

MATCH SHEET 10

PREPARED BY 	EXISTING POLE PROPOSED PEDIESTAL WATER VALVE FIBER MARKER GAS MANHOLE MANHOLE SEWER MANHOLE STORM DRAIN	RIGHT OF WAY LINE UTILITY EASEMENT TIE/LOG LINE WATER LINE GAS LINE BTU UNDERGROUND BTU OVERHEAD	PROPOSED COAXIAL CABLE PROPOSED FIBER CABLE PROPOSED DIRECTIONAL BORE EXISTING CABLE	ENGINEERED FOR COMCAST	GRAZOS COUNTY OLD SPANISH TRL TRANSPORT FIBER
	LEGEND RW - RIGHT OF WAY EOP - EDGE OF PAVEMENT DR - DRIVEWAY POW - PAVED DRIVEWAY	NOTES BORE HOLE TO BE FILLED SAME DAY VAULT HOLE TO BE FILLED SAME DAY ALL HOLE TO BE TAMPED AND SOODED	NO SCALE SHEET 9 OF 11		

MATCH SHEET 9

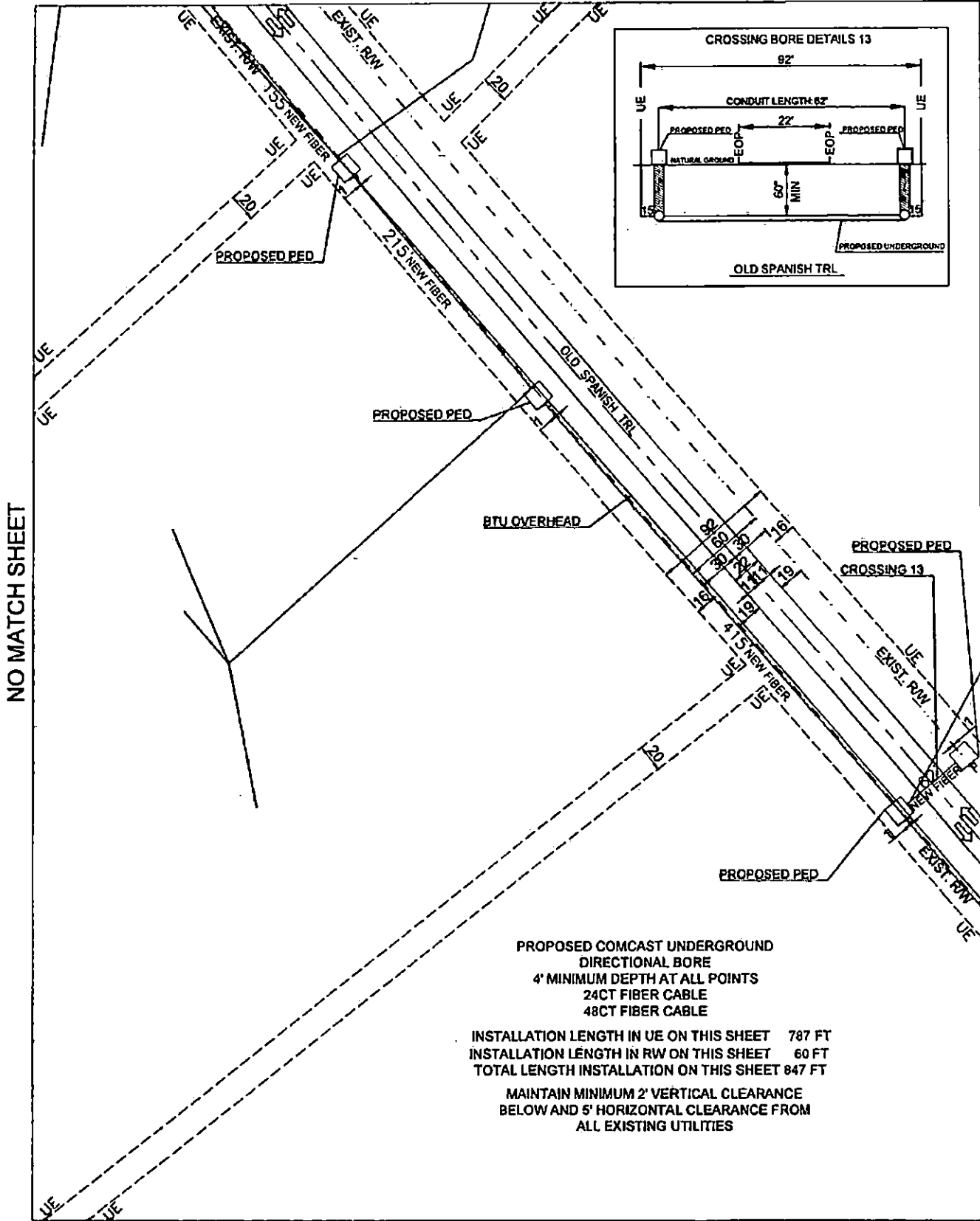

NO MATCH SHEET

MATCH SHEET 11

**PROPOSED COMCAST UNDERGROUND
DIRECTIONAL BORE**
 4' MINIMUM DEPTH AT ALL POINTS
 24CT FIBER CABLE
 48CT FIBER CABLE

INSTALLATION LENGTH IN UE ON THIS SHEET 787 FT
 INSTALLATION LENGTH IN RW ON THIS SHEET 60 FT
 TOTAL LENGTH INSTALLATION ON THIS SHEET 847 FT

MAINTAIN MINIMUM 2' VERTICAL CLEARANCE
 BELOW AND 5' HORIZONTAL CLEARANCE FROM
 ALL EXISTING UTILITIES

NO MATCH SHEET

PREPARED BY 	EXISTING POLE PROPOSED PEDestal WATER VALVE FIBER MARKER GAS MARKER MANHOLE SEWER MANHOLE STORM DRAIN	RIGHT OF WAY LINE UTILITY EASMENT TELCO LINE WATER LINE GAS LINE BTU UNDERGROUND BTU OVERHEAD	PROPOSED COAXIAL CABLE PROPOSED FIBER CABLE PROPOSED DIRECTIONAL BORE EXISTING CABLE		ENGINEERED FOR 	BRAZOS COUNTY OLD SPANISH TRL TRANSPORT FIBER
	LEGEND: RW - RIGHT OF WAY EOP - EDGE OF PAVEMENT LW - DRIVEWAY PDW - PAVED DRIVEWAY	NOTES: BORE HOLES TO BE FILLED SAME DAY VALVE HOLES TO BE FILLED SAME DAY ALL HOLES TO BE TAMPED AND SOCKED	NO SCALE SHEET 10 OF 11			

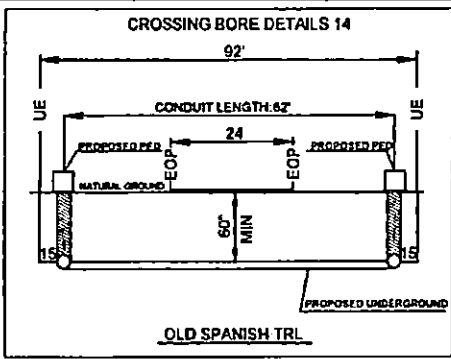

MATCH SHEET 10

NO MATCH SHEET

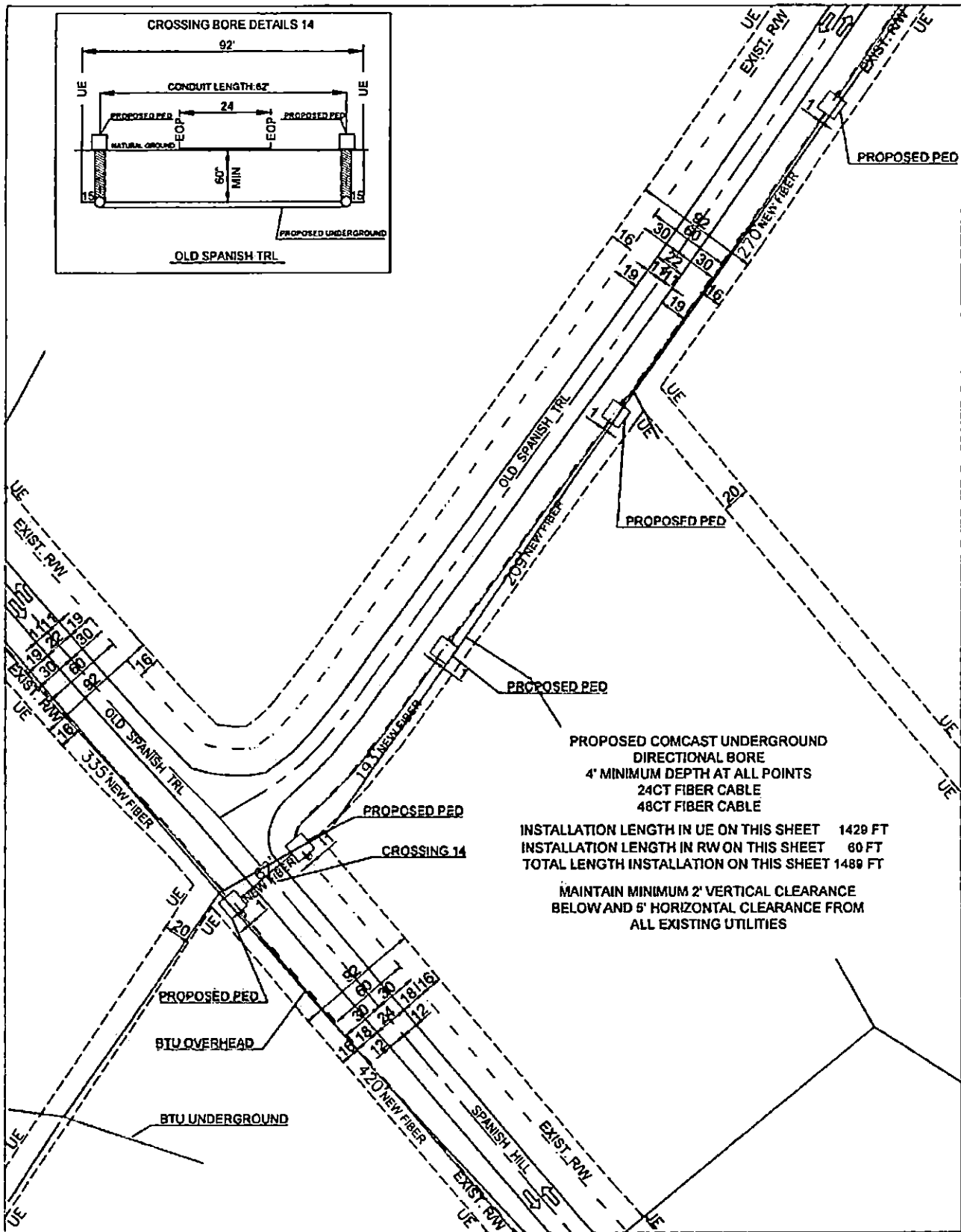

PROPOSED COMCAST UNDERGROUND
 DIRECTIONAL BORE
 4" MINIMUM DEPTH AT ALL POINTS
 24CT FIBER CABLE
 48CT FIBER CABLE
 INSTALLATION LENGTH IN UE ON THIS SHEET 1428 FT
 INSTALLATION LENGTH IN RW ON THIS SHEET 60 FT
 TOTAL LENGTH INSTALLATION ON THIS SHEET 1489 FT
 MAINTAIN MINIMUM 2' VERTICAL CLEARANCE
 BELOW AND 5' HORIZONTAL CLEARANCE FROM
 ALL EXISTING UTILITIES

MATCH SHEET 12

PREPARED BY 	EXISTING POLE PROPOSED PEDESTAL WATER VALVE FIBER MARKER GAS MARKER SEWER MAN-HOLE STORM DRAIN	RIGHT OF WAY LINE UTILITY EASMENT TELCO LINE WATER LINE GAS LINE BTU UNDERGROUND BTU OVERHEAD	PROPOSED COAXIAL CABLE PROPOSED FIBER CABLE PROPOSED DIRECTIONAL BORE EXISTING CABLE		ENGINEERED FOR 	BRAZOS COUNTY OLD SPANISH TRL SPANISH HILL TRANSPORT FIBER
	LEGEND RW - RIGHT OF WAY EOP - EDGE OF PAVEMENT DRY - DRIVEWAY POW - PAVED DRIVEWAY	NOTES BORE HOLE TO BE FILLED SAME DAY VAULT HOLE TO BE FILLED SAME DAY ALL HOLE TO BE TAMPED AND BODDED	NO SCALE SHEET 11 OF 11			

MATCH SHEET 11

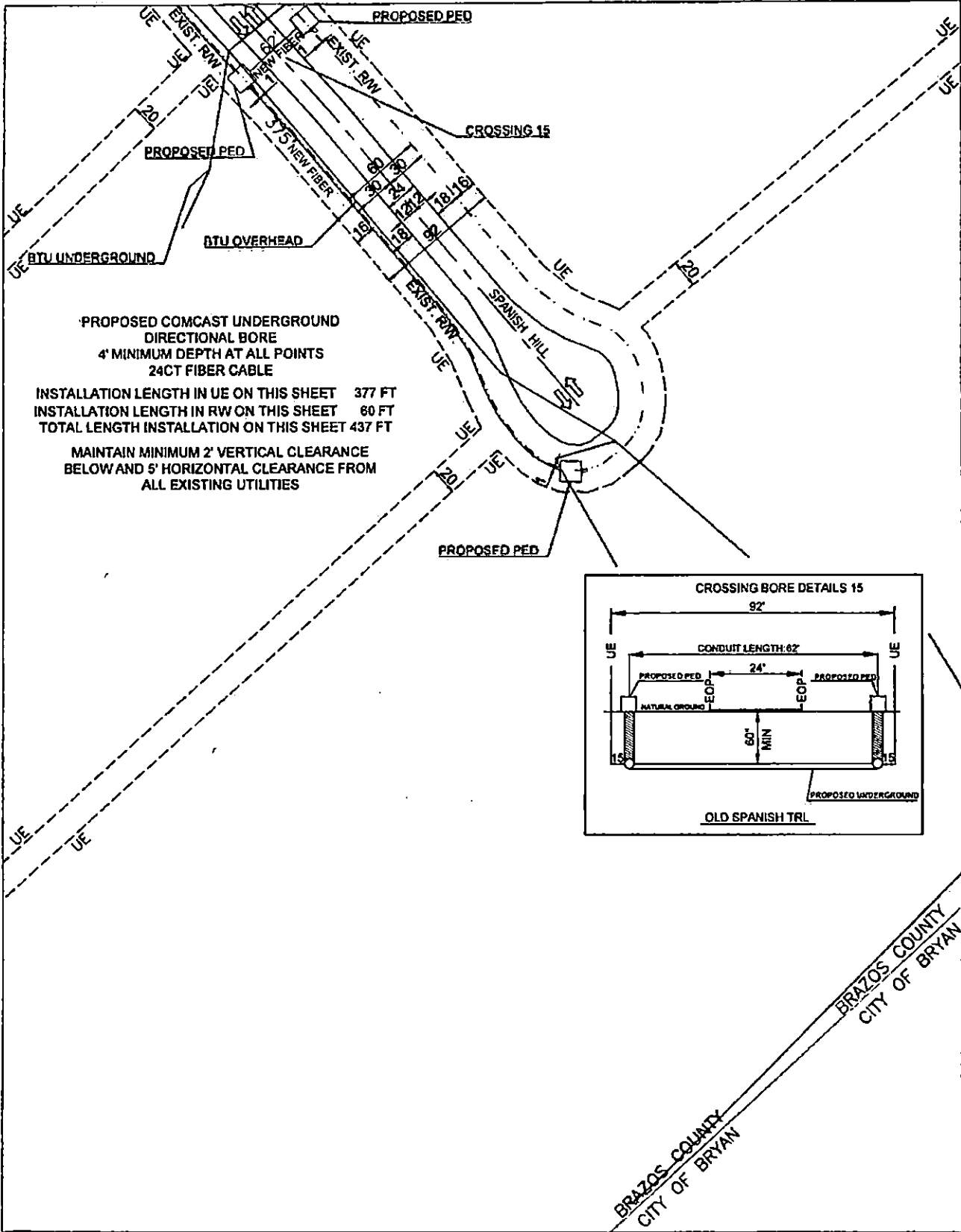

NO MATCH SHEET

NO MATCH SHEET

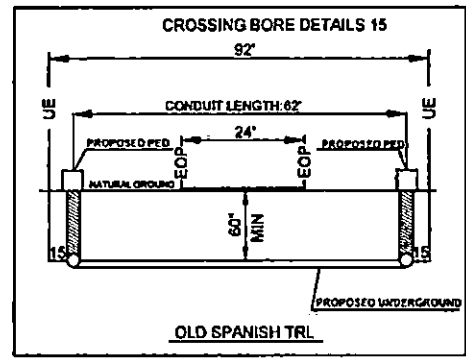

BRAZOS COUNTY
CITY OF BRYAN

MATCH SHEET 17

PREPARED BY 			ENGINEERED FOR 	BRAZOS COUNTY SPANISH HILL TRANSPORT FIBER
	LEGEND: RW - RIGHT OF WAY EOP - EDGE OF PAYMENT OVE - DRIVEWAY POW - PAVED DRIVEWAY		NOTES: BORE HOLE TO BE FILLED SAME DAY VISIT HOLE TO BE FILLED SAME DAY ALL HOLE TO BE TAMPED AND SOGDED	NO SCALE SHEET 12 OF 11

NO MATCH SHEET

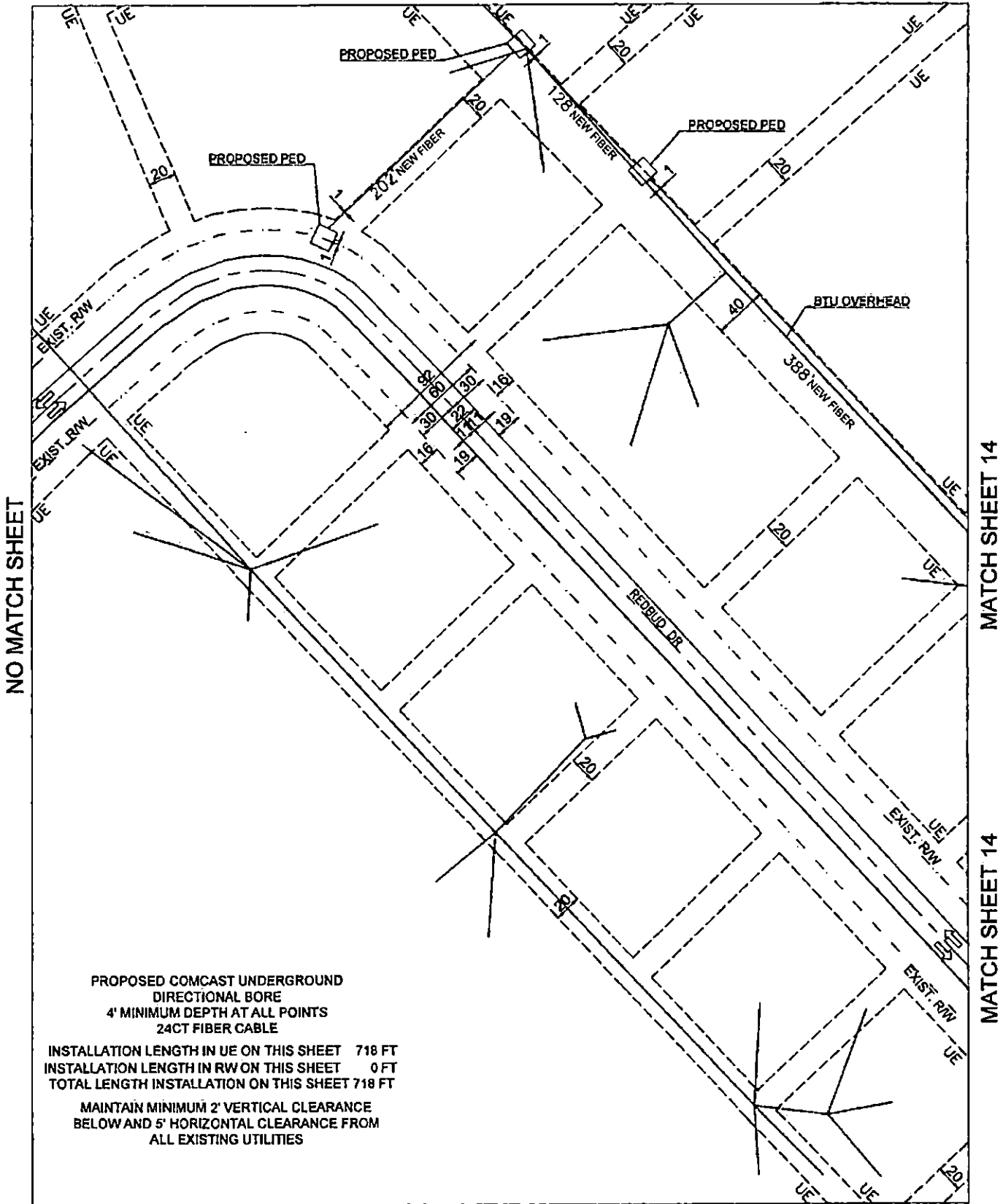

NO MATCH SHEET

MATCH SHEET 14

MATCH SHEET 14

PROPOSED COMCAST UNDERGROUND
 DIRECTIONAL BORE
 4' MINIMUM DEPTH AT ALL POINTS
 24CT FIBER CABLE

INSTALLATION LENGTH IN UE ON THIS SHEET 718 FT
 INSTALLATION LENGTH IN RW ON THIS SHEET 0 FT
 TOTAL LENGTH INSTALLATION ON THIS SHEET 718 FT

MAINTAIN MINIMUM 2' VERTICAL CLEARANCE
 BELOW AND 5' HORIZONTAL CLEARANCE FROM
 ALL EXISTING UTILITIES

NO MATCH SHEET

PREPARED BY 	EXISTING POLE PROPOSED PEDestal WATER VALVE FIBER MARKER GAS MARKER MANHOLE SEWER MANHOLE STORM DRAIN	RIGHT OF WAY LINE UTILITY EASMENT TELCO LINE WATER LINE GAS LINE STU UNDERGROUND STU OVERHEAD	PROPOSED COAXIAL CABLE PROPOSED FIBER CABLE PROPOSED DIRECTIONAL BORE EXISTING CABLE		ENGINEERED FOR 	BRAZOS COUNTY REDBUD OR TRANSPORT FIBER
	LEGEND: RW - RIGHT OF WAY EOP - EDGE OF PAVEMENT OP - OPENWAY PPD - PAVED DRIVEWAY	NOTES: BORE HOLE TO BE FILLED SAME DAY VALVE HOLE TO BE FILLED SAME DAY ALL HOLE TO BE TAMPED AND SODDED	NO SCALE SHEET 13 OF 17			

NO MATCH SHEET

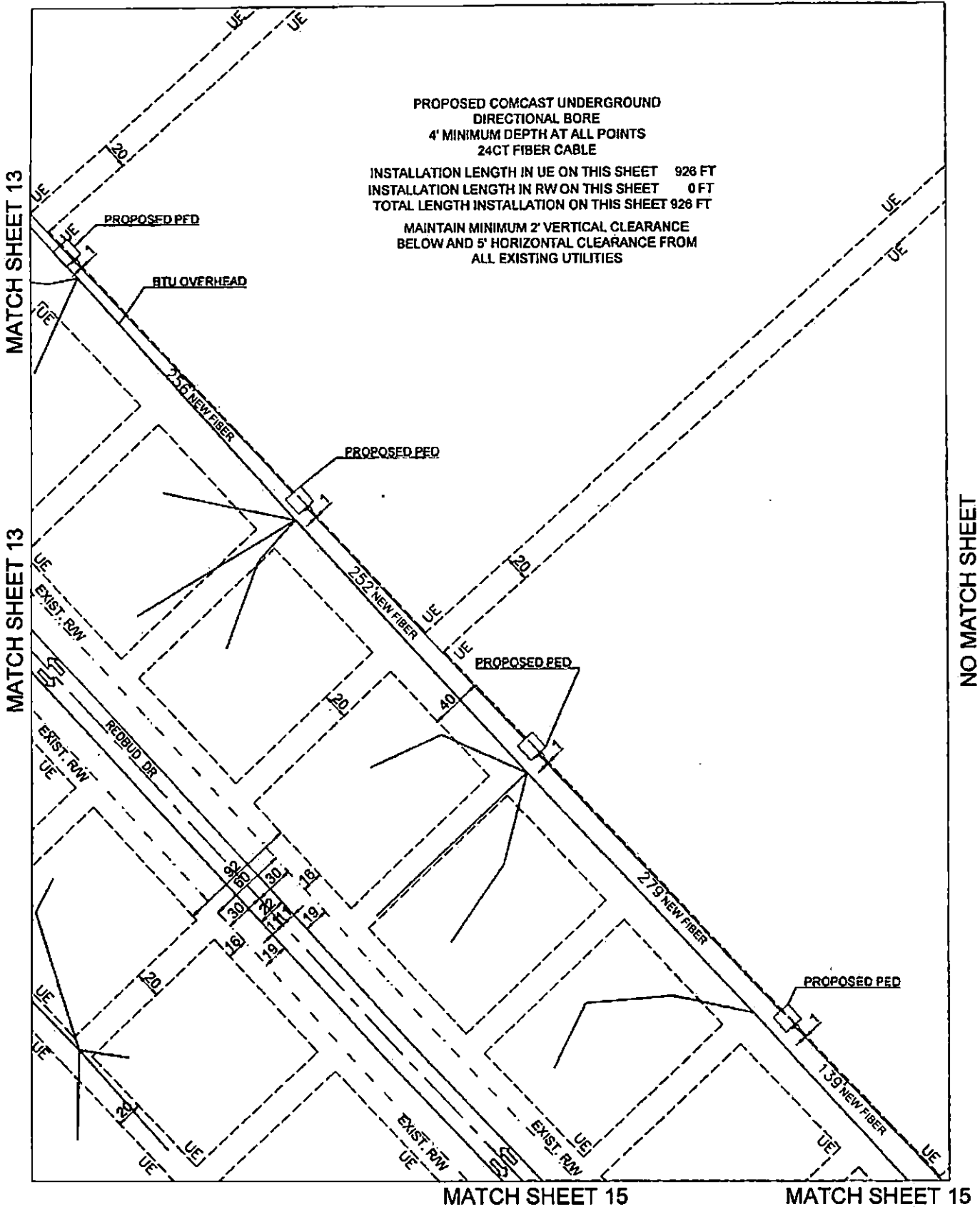

MATCH SHEET 15

MATCH SHEET 15

NO MATCH SHEET

PREPARED BY: 	EXISTING POLE PROPOSED PEDESTAL WATER VALVE FIBER MARKER GAS MARKER MANHOLE SEWER MANHOLE STORM DRAIN	RIGHT OF WAY LINE UTILITY EASEMENT WATER LINE GAS LINE BTU UNDERGROUND BTU OVERHEAD	PROPOSED COAXIAL CABLE PROPOSED FIBER CABLE PROPOSED DIRECTIONAL BORE EXISTING CABLE		ENGINEERED FOR 	BRAZOS COUNTY REDBUD DR TRANSPORT FIBER
	LEGEND RW - RIGHT OF WAY TOP - EDGE OF PAVEMENT DRY - DRIVEWAY PDM - PAVED DRIVEWAY	NOTES BORE HOLE TO BE FILLED SAME DAY VALVE HOLE TO BE FILLED SAME DAY ALL HOLE TO BE TAMPED AND SOCCED	HO SCALE SHEET 14 OF 17			

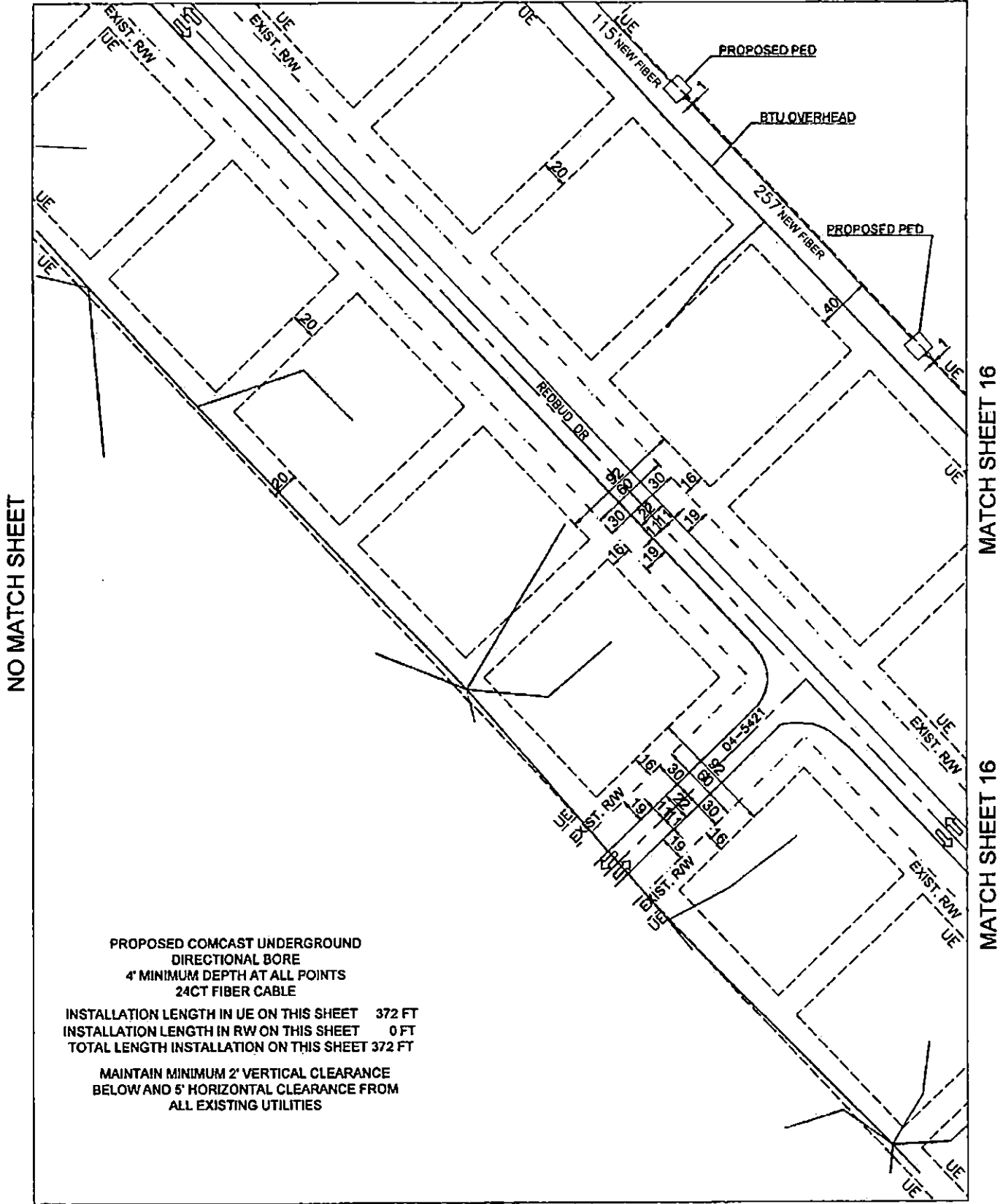

PROPOSED COMCAST UNDERGROUND
 DIRECTIONAL BORE
 4' MINIMUM DEPTH AT ALL POINTS
 24CT FIBER CABLE

INSTALLATION LENGTH IN UE ON THIS SHEET 372 FT
 INSTALLATION LENGTH IN RW ON THIS SHEET 0 FT
 TOTAL LENGTH INSTALLATION ON THIS SHEET 372 FT

MAINTAIN MINIMUM 2' VERTICAL CLEARANCE
 BELOW AND 5' HORIZONTAL CLEARANCE FROM
 ALL EXISTING UTILITIES

NO MATCH SHEET

MATCH SHEET 16

MATCH SHEET 16

NO MATCH SHEET

PREPARED BY: 	EXISTING POLE PROPOSED PEDESTAL WATER VALVE FIBER MARKER GAS MARKER MANHOLE SEWER MANHOLE STORM DRAIN	RIGHT OF WAY LINE UTILITY EASEMENT TELCO LINE WATER LINE GAS LINE STU UNDERGROUND STU OVERHEAD	PROPOSED COAXIAL CABLE PROPOSED FIBER CABLE PROPOSED DIRECTIONAL BORE EXISTING CABLE		ENGINEERED FOR 	BRAZOS COUNTY REDBUD DR TRANSPORT FIBER
	LEGEND RW - FRONT OF WALK COP - EDGE OF PAVEMENT DOW - DRIVEWAY POW - PAVED DRIVEWAY	NOTES BORE HOLE TO BE FILLED SAME DAY VAULT HOLE TO BE FILLED SAME DAY ALL HOLES TO BE TAMPED AND MENDED	NO SCALE SHEET 15 OF 17			

NO MATCH SHEET

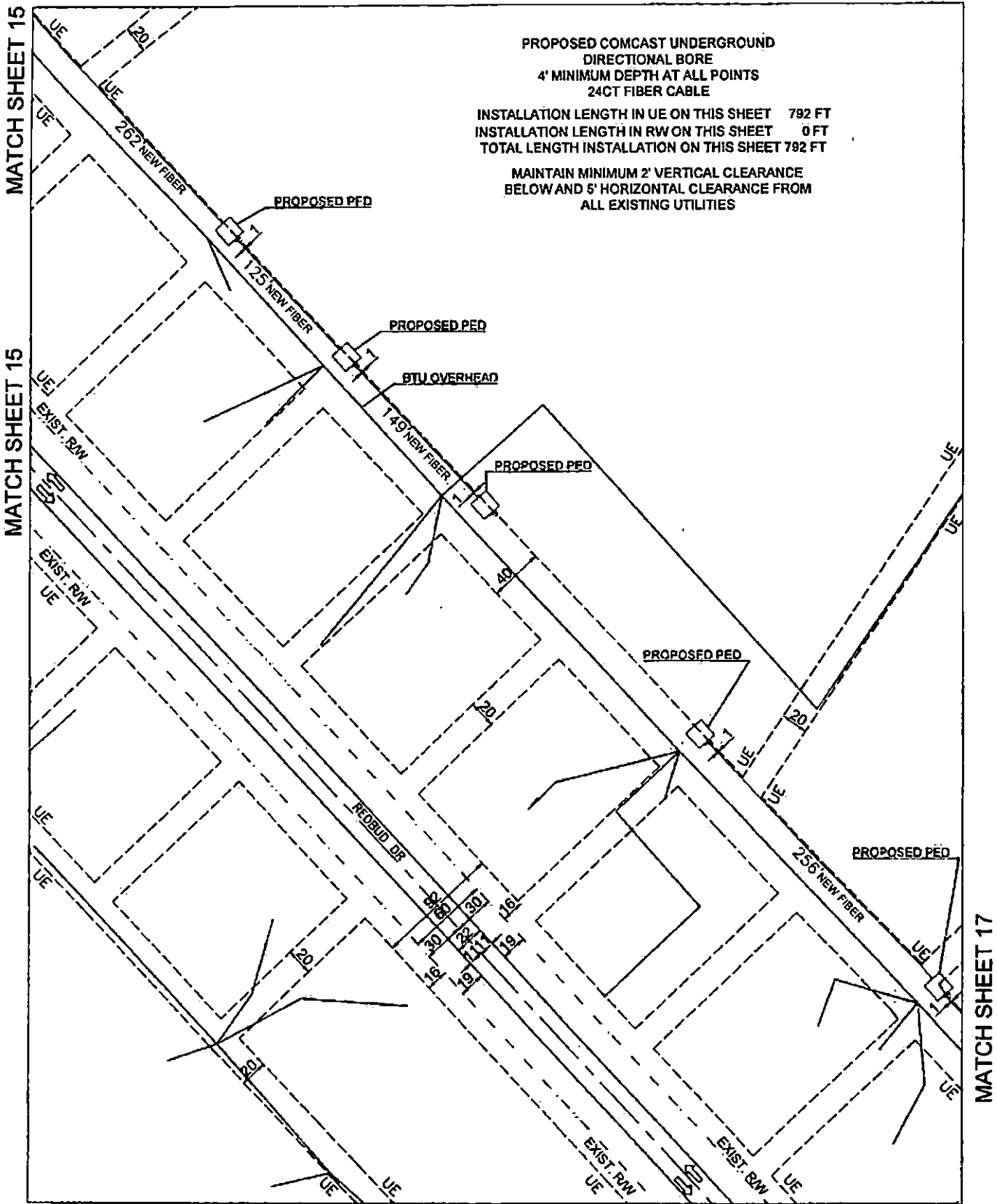

NO MATCH SHEET

PREPARED BY: 			ENGINEERED FOR 	BRAZOS COUNTY REDBUD DR TRANSPORT FIBER
	LEGEND RW - RIGHT OF WAY EOP - EDGE OF PAVEMENT DOW - DRIVEWAY POW - PAVED DRIVEWAY		NOTES BORE HOLE TO BE FILLED SAME DAY VALVE HOLE TO BE FILLED SAME DAY ALL HOLE TO BE TAMPED AND SODDED	NO SCALE SHEET 16 OF 17

NO MATCH SHEET

MATCH SHEET 16

PROPOSED COMCAST UNDERGROUND
DIRECTIONAL BORE
4" MINIMUM DEPTH AT ALL POINTS
24CT FIBER CABLE
48CT FIBER CABLE

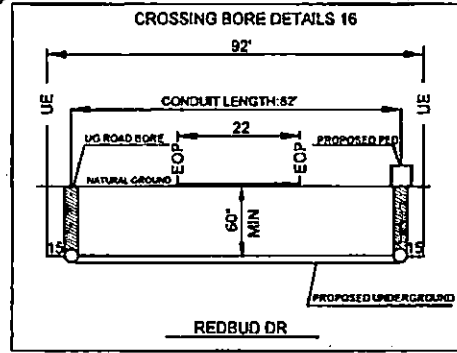

INSTALLATION LENGTH IN UE ON THIS SHEET 1016 FT
INSTALLATION LENGTH IN RW ON THIS SHEET 60 FT
TOTAL LENGTH INSTALLATION ON THIS SHEET 1076 FT

MAINTAIN MINIMUM 2' VERTICAL CLEARANCE
BELOW AND 5' HORIZONTAL CLEARANCE FROM
ALL EXISTING UTILITIES

TOTAL INSTALLATION LENGTH 14473 FT
AERIAL: 0 FT
UG: 14473 FT
START 30.738050, -96.462496
END 30.726355, -96.458801

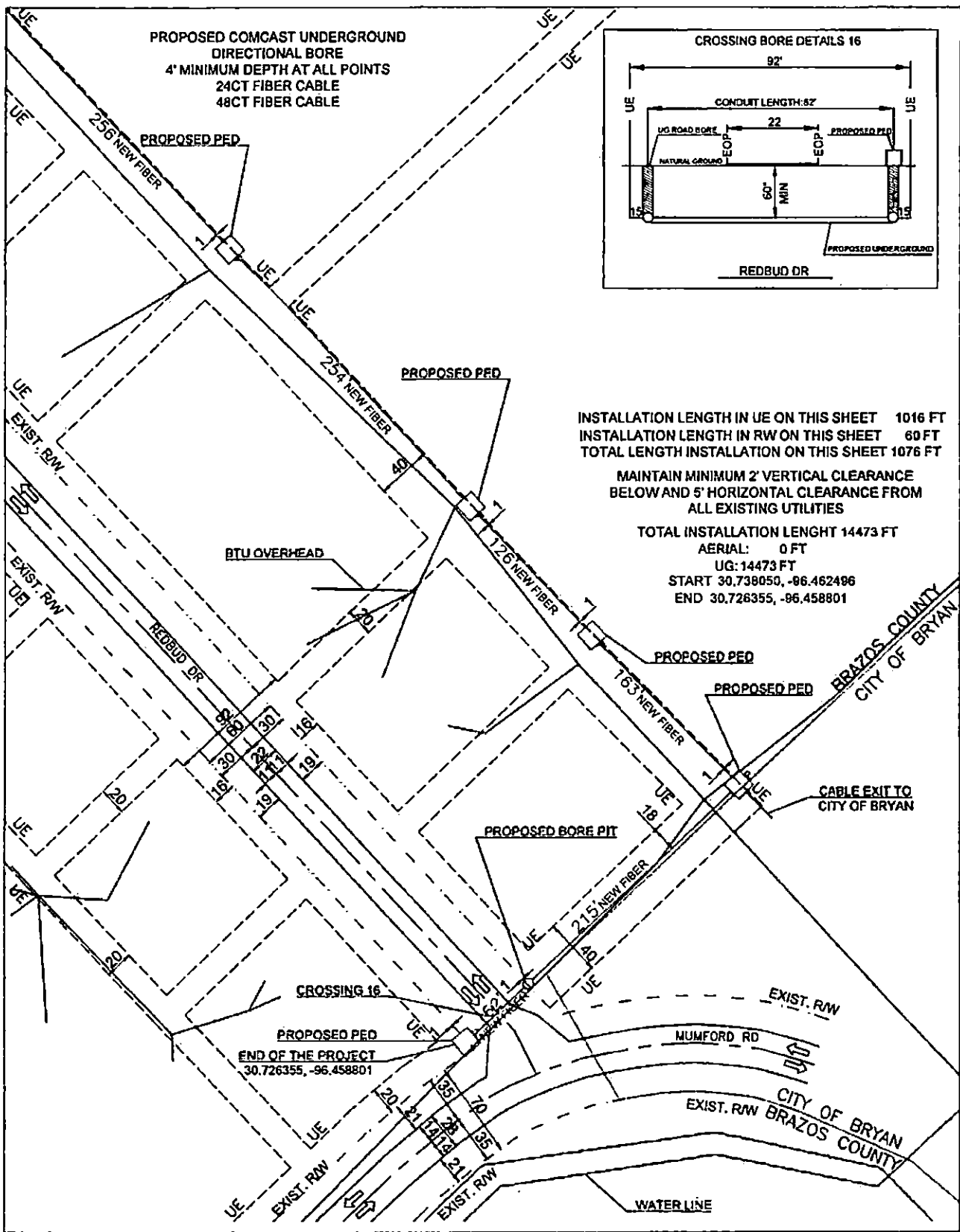

MATCH SHEET 12

NO MATCH SHEET

<p>PREPARED BY</p> <p>QUASAR, INC.</p>	<p>EXISTING POLE</p> <p>PROPOSED PEDestal</p> <p>WATER VALVE</p> <p>FIBER MARKER</p> <p>GAS MARKER</p> <p>MANHOLE</p> <p>SEWER MANHOLE</p> <p>STORM DRAIN</p>	<p>RIGHT OF WAY LINE</p> <p>UTILITY ELEMENT</p> <p>TELCO LINE</p> <p>WATER LINE</p> <p>GAS LINE</p> <p>BTU UNDERGROUND</p> <p>BTU OVERHEAD</p>	<p>PROPOSED COAXIAL CABLE</p> <p>PROPOSED FIBER CABLE</p> <p>PROPOSED DIRECTIONAL BORE</p> <p>EXISTING CABLE</p>		<p>ENGINEERED FOR</p> <p>BRAZOS COUNTY</p> <p>REDBUD DR</p> <p>TRANSPORT FIBER</p>
	<p>LEGEND</p> <p>RW - RIGHT OF WAY</p> <p>EOP - EDGE OF PAVEMENT</p> <p>CH - DRIVEWAY</p> <p>POW - PAVED DRIVEWAY</p>	<p>NOTES</p> <p>BORE HOLE TO BE FILLED SAME DAY</p> <p>VAULT HOLE TO BE FILLED SAME DAY</p> <p>ALL HOLE TO BE TAMPED AND SOODED</p>	<p>COMCAST</p>	<p>NO SCALE</p> <p>SHEET 17 OF 17</p>	

**BRAZOS COUNTY ROADWAY SAFETY AND ROAD
PRESERVATION STANDARDS FOR WORK CONDUCTED IN
BRAZOS COUNTY RIGHTS OF WAY**

A. General Requirements

1. Adequate drainage shall be maintained in ditches at all times.
2. Permittee will use best management practices ("BMP") (EPA and TCEQ both provide lists of examples of BMPs) to minimize erosion and sedimentation resulting from the proposed installation.
3. The permittee shall take precautions to avoid damage to property. All County Right of Way and property shall be restored to its original condition, as far as practical, in the opinion of the County Engineer or appointed representative.
4. The construction and maintenance of such utility shall not interfere with the property or rights of a prior occupant.
5. Permittee shall not interfere with other utilities located in the right of way. In the event damages occur, permittee will be liable to the County or other utilities running through the right of way.
6. County Engineer shall determine whether or not permittee's plans shall inconvenience the public. If it is determined that inconvenience to the public exists, then the County Engineer will decide whether such project will be allowed or if an alternative exists so as not to inconvenience the public.

B. Safety Requirements

1. Proper traffic control measures must be put in place prior to beginning work and remain in place during the duration of the job. All traffic control measures must follow the Texas Manual of Uniform Traffic Control Devices (TMUTCD). See Traffic Control Requirements below.
2. During construction, all safety regulations of the Texas Department of Transportation shall be observed.
3. Permittee must take such precautions and measures, including placing and displaying safety devices, as may be necessary, in order to safely conduct the public through the project area. Company shall provide flagmen, signs, signals or devices necessary to provide complete safety to the public.
4. Adequate provisions must be made to cause minimum inconveniences to traffic and adjacent property owners.
5. No cable, conduit and/or pole line shall be laid, constructed, maintained and/or repaired so as to constitute a danger or hazard of any kind to persons or vehicles using such road. Any poles placed in the Right of Way for future installation shall be placed at the back of the Right of Way. Exceptions may be approved by the County Engineer.

C. Traffic Control Plan

1. A traffic control plan, pursuant to the TMUTCD or Engineered Traffic Control Plan must be provided for the following:
 - a. Any construction (i.e. pit, excavation, hole) left open over night, requires specific nighttime traffic control measures pursuant to the TMUTCD;
 - b. If construction is within ten (10) feet of the roadway; or
 - c. Any work performed in the road right-of-way;

2. Plan must be attached to the permit and kept at the job site any time work is being performed.
3. Plan must set forth the time of completion for the job.

D. Design Standards

1. All overhead installations shall conform to clearance standards of the Texas Department of Transportation and the pole be placed in the designated area for power specified as set forth in the *Texas Utilities Code, Section 181.045*.
2. All pole installation (including lighting) shall be placed at the backside of the Right of Way to ensure safety to the public. Any pole placed in violation of this requirement will be required to be moved to the appropriate location at the company's expense. Exceptions may be approved by the County Engineer.
3. All underground installations shall (these are minimum depths – utility may place deeper):
 - a. be placed at a minimum depth of forty-eight (48) inches below the top of the pavement;
 - b. be at least thirty-six (36) inches below ditch flow line when installation is within the area measured from top of bank to top of bank;
 - c. be at least forty-eight (48) inches below ditch flow line if low pressure gas or petroleum lines. For high pressure gas and petroleum lines, see High Pressure Pipelines requirements listed below;
 - d. not be closer than ten (10) feet from the edge of pavement. Exceptions may apply in rights of way of less than 60'.
4. Water Lines: All water lines must be a minimum 36-inches below the ditch flow line and cased. Waterlines shall be cased if crossing under the roadway.
5. Utilities in all new developments that have 60 feet or greater of right of way shall be installed within designated locations based upon the type of utility. The locations shall be as follows: (measured from back of right-of-way).
 - Power – 0-2 feet, nominally 1'
 - Phone – 2-4 feet, nominally 3'
 - Gas – 4-6 feet, nominally 5'
 - Cable – 6-8 feet, nominally 7'
6. Utilities with less than 60 feet right-of-way in all new developments shall install the utility in a similar manner as referenced in No. 3 above, however, the County Engineer or its designated representative will provide final approval of each utility location.
7. The length of any trench to be opened in advance of the pipe, conduit or ducts may not be longer than 400' if left open over night or unattended.
8. Crossings under a county road shall:
 - a. be bored or jacked. **ABSOLUTELY NO OPEN CUTS WITHIN COUNTY ROAD PAVEMENT;**
 - b. be pressure grouted for the full length of the crossing *if* the annular space between pipe and casing and soil exceeds one (1) inch. Brazos County must be given 24 hours notice of pressure grouting operations and have the opportunity to have an inspector on site to observe pressure grouting operations;
 - c. TxDOT Standard Specification Item 476 shall be followed for all boring, jacking, tunneling and joints.
9. Bore Pits
 - a. no pits shall remain open longer than 2 days;

- b. all pits shall have proper traffic control measures in place. See Traffic Control Plan listed above.
 - c. pits shall NOT be located within ten (10) feet from the edge of pavement without prior approval from the County Engineer or his representative;
 - d. when pits are to remain open for more than 8 hours, due diligence will be used in protecting the spoil pile to prevent drainage problems;
 - e. based upon soil conditions, the County Engineer or his representative may require shoring to protect pavement integrity;
 - f. based upon soil conditions, the County Engineer or his representative may require pits be placed further from the edge of road.
10. Any installation within ten (10) feet of edge of pavement shall meet the following:
- a. location must be approved by the County Engineer or his representative
 - b. backfilled with cement stabilized material.
 - c. based upon soil conditions, the County Engineer or his representative may require shoring to protect pavement integrity.
 - d. All excess water and mud shall be removed from the trench prior to backfilling. Any backfill placed during a rainy period or at other times where excess water cannot be prevented from entering the trench will be considered TEMPORARY and shall be replaced with PERMANENT cement stabilized material as soon as weather permits;
 - e. All disturbed base and pavement materials shall be removed and restored to the satisfaction of the County Engineer or his representatives.
 - f. No side or lateral tamping to fill voids under the base and pavement materials is allowed.
11. Company must be careful to not jeopardize the slope or integrity of the shoulder of the road. In the event Company damages the slope, shoulder or any other portion of the right-of-way, Company will be responsible for repairing the damage and replacing the right-of-way to the condition it was prior to commencing construction.
12. Operation of construction and/or maintenance equipment on the traveled surface of any improved County road will not be permitted, except in an instance whereby the laying, construction, maintenance and/or repair of cables, conduits and/or pole lines cannot be accomplished by any other method and in this event all such equipment shall be of the rubber tire variety. Appropriate traffic control shall be provided meeting TMUTCD requirements.
13. In the event said construction and/or maintenance and/or repair requires Company to remove, cut or jeopardize any section of the road (asphalt, cement, road base, etc), Company will be required to provide a performance bond or letter of credit securing necessary repairs. Said bond amount will be determined by the County Engineer.
14. The applicant shall submit a letter of "No Objection" from the Army Corps of Engineers for all designated wetlands and environmentally sensitive lands.

E. Emergency work

- 1. In the event Company is required to perform emergency services, that requires excavation in a County Right of Way, and unable to notify the County Engineer prior to conducting emergency repairs, Company shall notify County Engineer within 24 hours of beginning construction/repairs. This will allow the County Engineer and Road & Bridge Office an opportunity to inspect the site to ensure the integrity of the County Right of Way and traffic safety controls used.

F. Repairs to existing facilities

1. Maintenance and/or repair to existing cables, conduits, and/or pole lines which require disturbance of the soil, shall not be performed until plans describing such maintenance and/or repair have been approved by the County Engineer or designated representative and a permit has been obtained.

G. Relocation of utilities:

1. When and if the County Engineer determines that it is necessary for the construction, repair, improvement, alteration or relocation of all or any portion of said road, any or all poles, wires, pipes, cables or other facilities and appurtenances authorized hereunder, shall be removed from said road, or reset or relocated thereon, as required by the County Engineer within a reasonable time as determined by the County Engineer and Utility Company, and at the expense of the Utility Company.

H. High Pressure Pipelines

1. All utility Permits for high pressure pipelines (generally 60 PSI or greater), whether pertaining to controlled access or non-controlled access installations, should contain the following additional information in the description of the permit.
 - diameter
 - wall thickness
 - material specification
 - minimum yield strength
 - maximum operation pressure of the pipeline
2. With the exception of the maximum operation pressure of the pipeline, this information is to be supplied for both the carrier pipe and the casing.
3. Assurance must also be given that the installation material and design meet the minimum Federal Safety Standards for Liquid and Gas Pipe Lines. Assurance must be provided on company letterhead and signed by an authorized representative of the company.

4. Petroleum Pipelines:

<u>Type of Pipeline</u>	<u>Depth (below deepest ditch grade)</u>	<u>Special Requirements</u>
Encased Pipe	Less than 10'	Must be covered with concrete pad at least 36" deep
Encased Pipe	Greater than 10'	No concrete pad required
Non-Cased Pipe	Less than 10'	Must be covered with concrete pad at least 48" deep
Non-Cased Pipe	Greater than 10'	No concrete pad required

The Concrete pad shall be minimum of 3" thick and width shall be pipe diameter plus 18" minimum.

5. Under no circumstances will a pipeline be installed parallel to a County Road within the Right-of-Way. Transmission lines have been determined to be petroleum pipelines (which includes natural gas lines) and shall not be parallel to a County Road.
6. Natural Gas Distribution is a line that serves the final customer.

DISCLAIMER: This standard is covered by the "Texas Engineering Practice Act". No warranty of any kind is made by TxDOT for any purpose whatsoever. TxDOT assumes no responsibility for the conversion of this standard to other formats or for indirect results of damage resulting from its use.

DATE FILED:

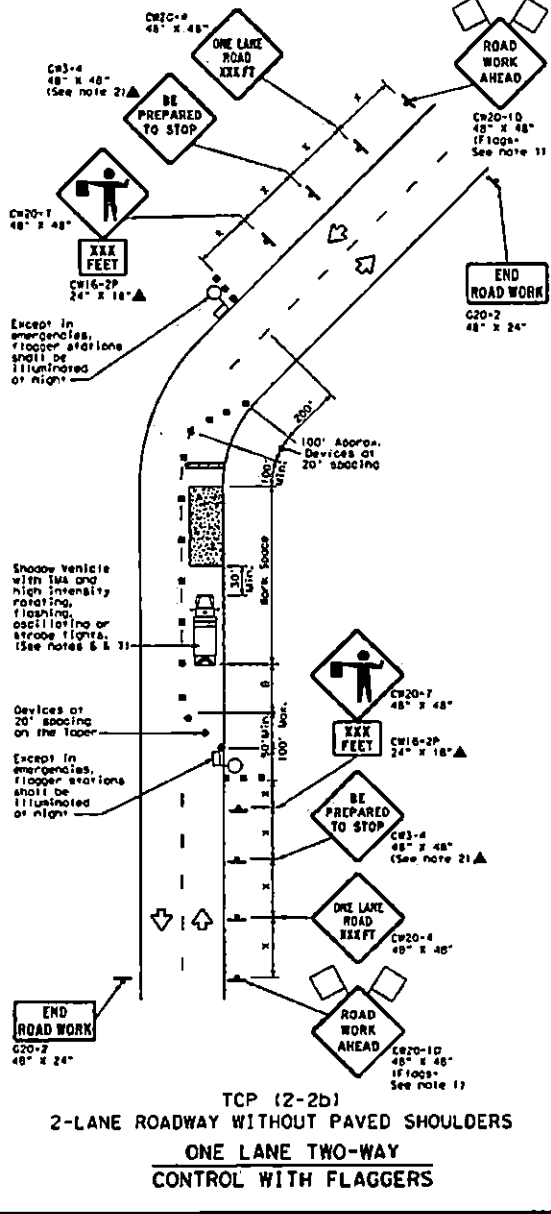
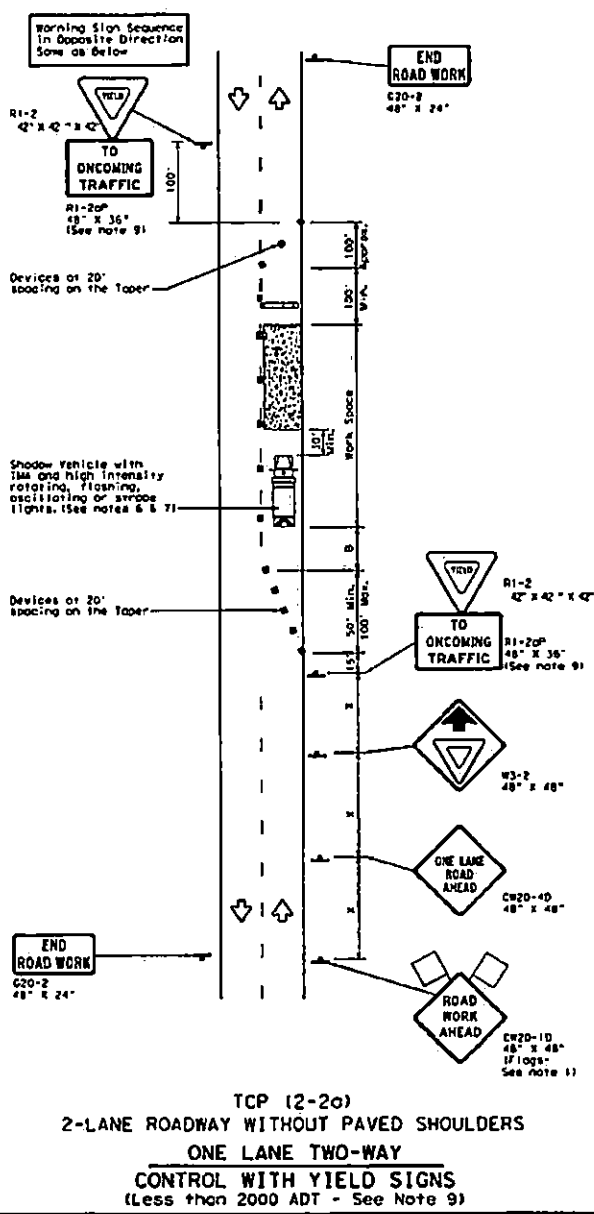

LEGEND

	Type 3 Barricade		Channelizing Devices
	Heavy Work Vehicle		Truck Mounted Attenuator (TMA)
	Trailer Mounted Flashing Arrow Board		Portable Changeable Message Sign (PCMS)
	Sign		Traffic Flow
	Flagger		Flagger

Posted Speed M	Formula	Minimum Desired Taper Lengths M			Suggested Maximum Spacing of Channelizing Devices		Minimum Sign Spacing Distance ft	Suggested Longitudinal Buffer Space ft	Stopping Distance
		10' or less	11' - 12'	12' or more	On a Taper	On a Tangent			
30	L = .5S	150'	165'	180'	30'	60'	120'	90'	200'
35		205'	225'	245'	35'	70'	160'	120'	250'
40	L = .6S	265'	295'	320'	40'	80'	240'	155'	305'
45		330'	365'	395'	45'	90'	320'	195'	365'
50	L = .7S	400'	440'	480'	50'	100'	400'	240'	425'
55		475'	520'	565'	55'	110'	500'	295'	495'
60	L = .8S	560'	610'	660'	60'	120'	600'	350'	570'
65		650'	705'	760'	65'	130'	700'	410'	645'
70	L = .9S	750'	810'	870'	70'	140'	800'	475'	730'
75		850'	915'	980'	75'	150'	900'	540'	820'

M Conventional Roads Only
M Taper lengths have been rounded off.
L Length of Taper (F) M Width of Offset (F) S Posted Speed (MPH)

TYPICAL USAGE

MOBILE	SHORT DURATION	SHORT TERM STATIONARY	INTERMEDIATE TERM STATIONARY	LONG TERM STATIONARY
	✓	✓	✓	✓

GENERAL NOTES

- Flags attached to signs where shown, are REQUIRED.
- All traffic control devices illustrated are REQUIRED, except those denoted with the triangle symbol may be omitted when stated elsewhere in the plan, or for routine maintenance work, when approved by the Engineer.
- The C20-4 "BE PREPARED TO STOP" sign may be installed after the C20-4 "ONE LANE ROAD XXX FT" sign, but proper sign spacing shall be maintained.
- Flaggers should use two-way radios or other methods of communication to control traffic.
- Length of work space should be based on the ability of flaggers to communicate.
- A Shadow Vehicle with a TMA should be used anytime it can be positioned 30 to 100 feet in advance of the area of crew exposure without adversely affecting the performance or quality of the work. If workers are no longer present but road or work conditions require the traffic control to remain in place, Type 3 Barricades or other channelizing devices may be substituted for the Shadow Vehicle and TMA.
- Additional Shadow Vehicles with TMAs may be positioned off the paved surface, next to those shown in order to protect a wider work space.

TCP (2-2a)

- The R1-2 "YIELD" sign traffic control may be used on projects with approaches that have adequate sight distance. For projects in urban areas, work space should be no longer than one half city block. In rural areas, roadways with less than 2000 ADT, work space should be no longer than 500 feet.
- The R1-2P "YIELD TO ONCOMING TRAFFIC" sign shall be placed on a support of a 7 foot minimum mounting height.

TCP (2-2b)

- Channelizing devices on the center line may be omitted when a pilot car is leading traffic and approved by the Engineer.
- If the work space is located near a horizontal or vertical curve, the buffer distances should be increased in order to maintain stopping sight distance to the flagger and a queue of stopped vehicles. (See table above).
- Flaggers should use 24" STOP/SLOW paddles to control traffic. Flags should be limited to emergency situations.

Notes:
The contractor must notify the precinct at least 48 hours before a lane closure.
No lanes shall be closed during the hours of 7:00 AM to 9:00 AM and 4:00 PM to 6:00 PM Monday through Friday.

Texas Department of Transportation

Traffic Operations Manual Standard

TRAFFIC CONTROL PLAN
ONE-LANE, TWO-WAY
TRAFFIC CONTROL

TCP (2-2) - 18

Date:	02/27/18	Rev:	0
Project:	02/27/18	Drawn:	02/27/18
Checked:	02/27/18	Reviewed:	02/27/18
Approved:	02/27/18	Scale:	AS SHOWN



**BRAZOS COUNTY
BRYAN, TEXAS**

DEPARTMENT:

NUMBER:

DATE OF COURT MEETING: 6/23/2026

ITEM: Proclamation 26-019 proclaiming July 4, 2026, Declaration of Independence Day and recognizing the 250th Anniversary of American Independence (America 250).

TO: Commissioners Court

DATE: 05/04/2026

FISCAL IMPACT: False

BUDGETED: False

DOLLAR AMOUNT: \$0.00

ATTACHMENTS:

File Name

[Proclamation - with America 250.pdf](#)

Description

Proclamation - America 250

Type

Cover Memo

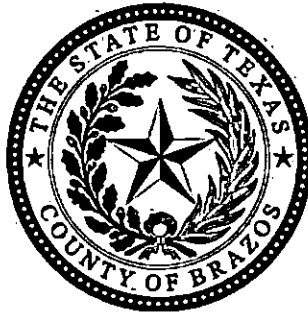

Proclamation

- Whereas:** On July 4, 2026, our nation will commemorate America 250, marking the 250th anniversary of the signing of the Declaration of Independence; and,
- Whereas:** The journey toward this historic milestone is an opportunity to reflect on our nation's past, honor the contributions of all Americans, and look ahead to the future generations who will carry forward the ideals of democracy and individual liberty that make the United States a unique nation in the world community; and,
- Whereas:** **NOW THEREFORE**, we, the Commissioners Court of Brazos County do hereby proclaim July 4, 2026 as

DECLARATION OF INDEPENDENCE DAY

and ask our citizens to join with the La Villita, William Scott and Come and Take It Chapters of the National Society of the Daughters of the American Revolution to reaffirm the ideals the framers of the Declaration of Independence had when they bravely created this great document of freedom for all Americans.

Proclaimed this 23rd day of June 2026.

A large, stylized handwritten signature in black ink, appearing to read "Duane Peters".

Duane Peters, County Judge

A handwritten signature in black ink, appearing to read "Bentley Nettles".

Commissioner Bentley Nettles
Precinct 1

A handwritten signature in black ink, appearing to read "Chuck Konderla".

Commissioner Chuck Konderla
Precinct 2

A handwritten signature in black ink, appearing to read "Fred Brown".

Commissioner Fred Brown
Precinct 3

A handwritten signature in black ink, appearing to read "Wanda J. Watson".

Commissioner Wanda J. Watson
Precinct 4



**BRAZOS COUNTY
BRYAN, TEXAS**

DEPARTMENT:

NUMBER:

DATE OF COURT MEETING: 6/23/2026

ITEM: Resolution 26-013 requesting permission to host the 2028 North and East Texas County Judges and Commissioners Conference in Bryan/College Station if selected by the committee.

TO: Commissioners Court

DATE: 06/15/2026

FISCAL IMPACT: False

BUDGETED: False

DOLLAR AMOUNT: \$0.00

ATTACHMENTS:

File Name

Description

Type

[Resolution - Permission to Host 2028 North and East Conference.pdf](#)

Resolution to Host 2028 North & East TX
Conference

Cover Memo



BRAZOS COUNTY
BRYAN, TEXAS
RESOLUTION

WHEREAS, Bryan/College Station has a diverse population of more than 230,000, all of whom would be thrilled to welcome the 2028 North and East Texas County Judges and Commissioners Conference and its attendees to share in our numerous attractions. With a nationally famous university, presidential library and vibrant economy, Bryan/College Station is a wonderful place to live and visit! Our convenient location is in the center of the geographic triangle formed by Houston, Dallas/Fort Worth, and Austin/San Antonio, and provides numerous attractions to visitors.

WHEREAS, we are home to Texas A&M University, which is one of the largest universities in the country, and home to the “Fighting Texas Aggies.” Founded in 1876 as Texas’ first public institution of higher learning, this land, sea and space grant institution includes an enrollment of more than 70,000 students studying for degrees in 17 academic colleges. In addition to nationally recognized degree programs, Texas A&M boasts a proud and decorated athletic history, which can be experienced at the Texas A&M Sports Museum.

WHEREAS, our community also serves as the gateway to the George Bush Presidential Library and Museum which houses the archives, and chronicles the life, of our nation’s 41st President. The museum exhibits reveal the unique influences and challenges that shaped George H.W. Bush’s life and presidency, including his time in the U.S. Navy during WWII as a pilot, as captain of Yale University Baseball Team, and through his storied political career.

WHEREAS, a short drive away from College Station is downtown Bryan, which was designated as a Texas Main Street City in 1992. This thriving cultural district is a mix of businesses, locally owned shops, restaurants, and museums, as well as serving as a gathering spot for the community every first Friday of the month.

WHEREAS, Bryan is home to Messina Hof Winery & Resort, which is one of the first and most-awarded wineries in Texas and continues to lead the charge in crafting quality wine from Texas vines. The beautiful grounds are open to tours, and visitors are encouraged to sample the 24 varietal wines at their state-of-the-art facility.

WHEREAS, our mix of cultures means that we have a great variety of authentic food from around the world, and nightlife with music that spans all genres. One of the only three African American museums in the State of Texas is in Bryan, and educational opportunities abound at the Brazos Valley Museum of Natural History, the Children’s Museum of the Brazos Valley, and Museum of the American GI.

WHEREAS, the variety of attractions, quality hotels, restaurants and entertainment venues make Bryan/College Station a premier destination for visitors. In addition to all that the community can offer, more than 80 percent of Texas’ population can drive to Bryan/College Station in less than three hours, making it accessible for all attendees. Our hope is that you will select our destination to experience all that we, and our surrounding communities, can provide for your conference and its attendees.

Now Be It Resolved, that the Brazos County Commissioners Court would like to request that you select Bryan/College Station as host for the 2028 North and East Texas County Judges and Commissioners Conference.

RESOLVED this 23 day of June, 2026.

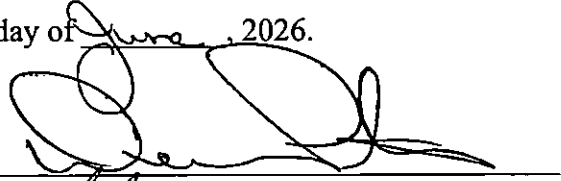

Duane Peters, County Judge

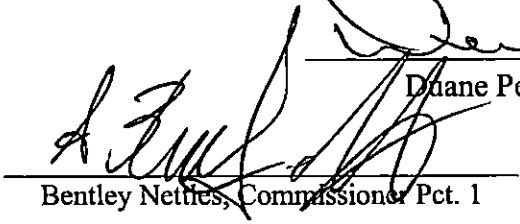

Bentley Nettles, Commissioner Pct. 1



Chuck Konderla, Commissioner Pct. 2



Fred Brown, Commissioner Pct. 3

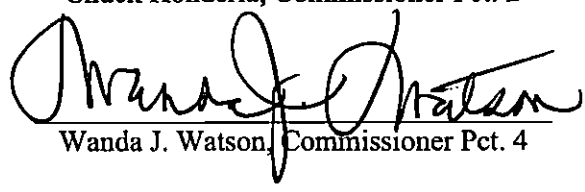

Wanda J. Watson, Commissioner Pct. 4



**BRAZOS COUNTY
BRYAN, TEXAS**

DEPARTMENT: Human Resources NUMBER:
DATE OF COURT MEETING: 6/23/2026
ITEM: Approval of addition to the Interim Compensation Administration Guidelines previously approved on June 9, 2026 regarding Promotion to Higher-Level Positions.
TO: Commissioners Court
DATE: 06/15/2026
FISCAL IMPACT: False
BUDGETED: False
DOLLAR AMOUNT: \$0.00
NOTES/EXCEPTIONS: Addition to the Interim Compensation Administration Guidelines previously approved on June 9,2026 regarding Promotion to Higher-Level Positions

ATTACHMENTS:

<u>File Name</u>	<u>Description</u>	<u>Type</u>
Interim Compensation Administration Guidelines - New Section (002).pdf	Interim Compensation Administration Guidelines - New Section	Cover Memo
Brazos County Human Resources Interim Compensation Guidelines - Updated 6.10.26 (002).pdf	Brazos County Human Resources Interim Compensation Guidelines - Updated 6.10.2026	Cover Memo

Per Court direction received on June 9, 2026, the following section will be added to the Brazos County Human Resources Interim Compensation Administration Guidelines (approved June 9, 2026):

4. Promotions to Higher-Level Positions

- Employees who are selected for and promoted into a position assigned to a higher pay grade may receive a promotional salary increase to recognize the additional duties, responsibilities, and accountability associated with the new position.

When an employee's current salary already exceeds the midpoint of the proposed pay grade for the new position, HR may recommend a promotional increase of up to 3%, provided sufficient funding is available or with budget amendment approval. The promotional increase is intended to recognize the advancement to a higher-level position and does not guarantee alignment to any specific point within the pay range.

APPROVED

Duane Peters
County Judge

6/23/26
Date

Brazos County Human Resources

Interim Compensation Administration Guidelines

(Effective through implementation of the new classification and compensation structure)

Purpose

As Brazos County transitions to a new classification and compensation structure, these interim guidelines are established to ensure that compensation decisions are made to:

- Support market alignment identified in the Compensation & Benefits Study
- Promote internal equity across departments
- Do not create additional misalignment or compression prior to full implementation

These guidelines are temporary and will remain in effect until the new structure is implemented.

Guiding Principles

All compensation actions during this transition period will be evaluated based on the following:

- **Market Alignment:** Priority will be given to employees currently compensated below market.
- **Internal Equity:** Actions should not create or worsen pay inequities within or across departments.
- **Future Alignment:** Decisions should align, to the extent possible, with the proposed classification and compensation structure.

General Guidance

1. Employees Below Market:

- May be considered for pay increases toward market alignment.
- Increases should not exceed the anticipated market midpoint.
- Priority group for FY '27 adjustments.

2. Employees At or Above Market:

- Pay increases are generally discouraged during the interim period.
- Requests that would move an employee further above market will require strong written justification as well as review and approval by HR.
- In most cases, adjustments should be deferred until implementation.

3. Reclassifications / Changes in Duties:

- Must reflect substantial and documented changes in job responsibilities. Title changes alone are not sufficient justification.
- Will require review and approval by HR.
- Where possible, positions will be evaluated against the proposed classification structure.

4. Promotions to Higher-Level Positions

- Employees who are selected for and promoted into a position assigned to a higher pay grade may receive a promotional salary increase to recognize the additional duties, responsibilities, and accountability associated with the new position.

When an employee's current salary already exceeds the midpoint of the proposed pay grade for the new position, HR may recommend a promotional increase of up to 3%, provided sufficient funding is available or with budget amendment approval. The promotional increase is intended to recognize the advancement to a higher-level position and does not guarantee alignment to any specific point within the pay range.

Prohibited / Restricted Actions

The following actions are strongly discouraged during the interim period:

- Increasing pay for employees already above market without documented justification.
- Title changes without corresponding duty changes.
- Adjustments that create known internal inequities.
- Use of budget availability as the sole justification for pay increases.

Administration

- HR will partner with departments to evaluate requests and provide guidance.
- These guidelines may be updated as needed during the transition period.
- These guidelines are effective immediately and will remain in place until the implementation of the new classification and compensation structure (anticipated FY '28).



**BRAZOS COUNTY
BRYAN, TEXAS**

DEPARTMENT: Information Technology NUMBER:
DATE OF COURT MEETING: 6/23/2026
ITEM: Request from Information Technology to approve the Artificial Intelligence Policy and Guidelines.
TO: Commissioners Court
FROM: Eric V. Caldwell, CGCIO
DATE: 05/07/2026
FISCAL IMPACT: False
BUDGETED: False
DOLLAR AMOUNT: \$0.00

NOTES/EXCEPTIONS: This policy will govern the use of Artificial Intelligence on County Information Resources to accomplish the following:

1. Ensure County data is protected from unauthorized access, use, or exposure.
2. Reduce reputational risk by providing a framework for the responsible, ethical and transparent use of AI within County processes.
3. Maximize the benefits of AI while minimizing the risk to internal County business.
4. Protect employee and resident data.

The policy has been reviewed by the Internal Stakeholders Review Group as required by the Policy for Adoption of New and Revised County Policies.

ATTACHMENTS:

File Name

[AI Policy and Guidelines.pdf](#)

Description

Policy and Guidelines on Artificial Intelligence

Type

Cover Memo

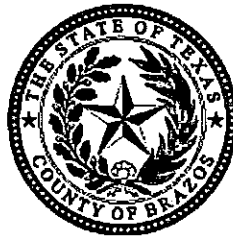

**BRAZOS COUNTY
BRYAN, TEXAS**

DEPARTMENT: Information Technology NUMBER:

DATE OF COURT MEETING: 6/23/2026

ITEM: Request from Information Technology to approve the Artificial Intelligence Policy and Guidelines.

TO: Commissioners Court

FROM: Eric V. Caldwell, CGCIO

DATE: 05/07/2026

FISCAL IMPACT: False

BUDGETED: False

DOLLAR AMOUNT: \$0.00

NOTES/EXCEPTIONS: This policy will govern the use of Artificial Intelligence on County Information Resources to accomplish the following:

1. Ensure County data is protected from unauthorized access, use, or exposure.
2. Reduce reputational risk by providing a framework for the responsible, ethical and transparent use of AI within County processes.
3. Maximize the benefits of AI while minimizing the risk to internal County business.
4. Protect employee and resident data.

The policy has been reviewed by the Internal Stakeholders Review Group as required by the Policy for Adoption of New and Revised County Policies.

ATTACHMENTS:

<u>File Name</u>	<u>Description</u>	<u>Type</u>
AI_Policy_and_Guidelines.pdf	Policy and Guidelines on Artificial Intelligence	Cover Memo

APPROVED



Duane Peters 6/23/26
County Judge Date

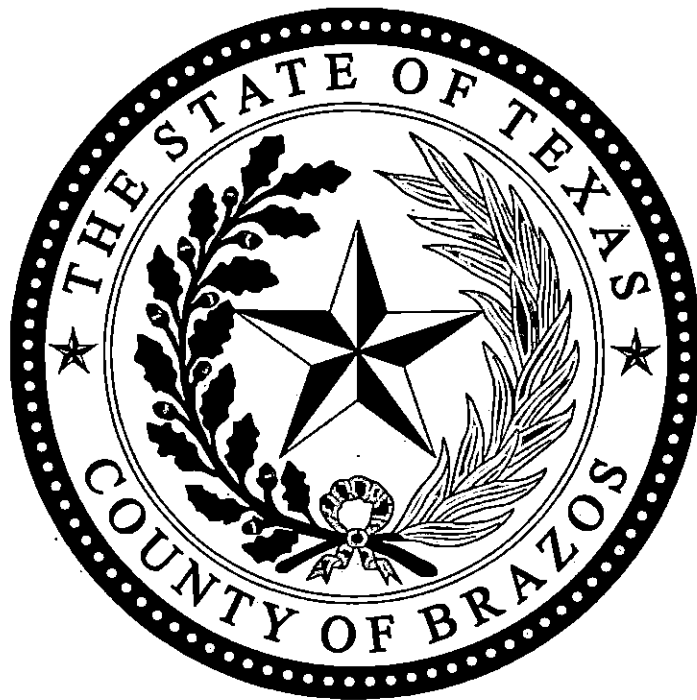

**BRAZOS COUNTY
ARTIFICIAL INTELLIGENCE POLICY AND
GUIDELINES**

JUNE 23, 2026

BRAZOS ★ COUNTY

Texas

CONTENTS

1. PREFACE 3

2. PURPOSE 3

3. SCOPE 4

4. DEFINITIONS 4

5. REQUIREMENTS 5

6. MEETING ATTENDANT AI TOOLS 6

7. ACQUISITION OF AI TECHNOLOGY 6

8. MONITORING AI TOOL USAGE: 7

9. PROHIBITED USES..... 7

10. VIOLATIONS..... 7

11. PROHIBITION OF CERTAIN AI TOOLS 8

12. BASIC RULES FOR AI USAGE 8

 a. Security and Privacy..... 8

 b. Bias and Ethics..... 9

 c. Accuracy 9

 d. Copyright..... 9

 e. Accountability and Transparency 9

1. PREFACE

“Artificial Intelligence (AI) is technology that allows computers to do tasks that usually require human thinking, such as answering questions, writing text, recognizing images, or making predictions. AI tools can help employees work more efficiently, but they can sometimes be wrong, incomplete, or biased. For that reason, AI should always be used with human review and good judgment.

AI technology is constantly changing, with new tools and risks emerging all the time. Because of this, this is a living document and will be reviewed and updated regularly to keep up with changes in technology, laws, and best practices.”

Note: The above was 100% generated using ChatGPT 5-mini.

2. PURPOSE

This policy governs the use of AI on County Information Resources. The purpose of this policy is to:

- Protect County data from unauthorized access and use.
- Reduce reputational risk by providing a framework for the responsible, ethical and transparent use of AI within County processes.
- Maximize the benefits of AI while minimizing the risk to internal County business.
- Protect employee and resident data.

This policy will be reviewed annually in accordance with the Policy for Adoption of New and Revised County Policies by a committee created by Commissioner’s Court, with opportunities for employee input during the review process. Additional reviews may occur as necessary to adapt to new technologies and practices. Note: This policy is preempted by Chapter 552 of the Texas Business and Commerce Code and if any part of this policy conflicts with Chapter 552, Chapter 552 shall take precedence.

3. SCOPE

This policy applies to all authorized users of County Information Resources who utilize AI Tools and technologies that are third-party or internally developed. The scope includes three primary areas:

- The use of AI to perform or support County business.
 - The use of anonymous or non-county managed accounts when accessed on County Information Resources.
 - The use of County-managed AI accounts, regardless of the device used. For the purposes of this policy, any account created with a Brazos County–issued email address is considered County-managed, regardless of whether it is associated with a paid or premium service.
-

4. DEFINITIONS

AI (Artificial Intelligence): AI refers to computer systems designed to perform tasks that typically require human intelligence, such as decision-making, problem-solving, and pattern recognition.

AI Tool: An AI Tool is software or a system that uses artificial intelligence technologies to analyze data, generate or modify content, automate tasks, or assist in decision-making processes. These tools operate with varying levels of independence and are designed to enhance efficiency, creativity, or functionality in support of user or organizational objectives.

LLM (Large Language Model): An LLM is a type of AI model trained on vast amounts of text data to understand and generate human-like language.

Generative AI: Generative AI refers to systems that can create new content—such as text, images, or audio based on patterns learned from existing data.

Chatbots: Chatbots are AI-powered software programs that simulate human conversation to assist users, answer questions, or perform tasks.

Machine Learning: Machine learning is a subset of AI that enables systems to learn from data and improve their performance on specific tasks without being explicitly programmed.

All other terms used in this document will be defined in the ‘Security Policy Standard Definitions document located at: [Standard Definitions](#)

5. REQUIREMENTS

Security and data privacy: County Users shall not submit protected or confidential data to any public AI Tools. This specifically includes Protected Health Information (PHI), Personally Identifiable Information (PII), Criminal Justice Information (CJI), proprietary information, confidential financial information, and contact details received from 3rd parties. Users should not name or specify Brazos County when using AI Tools to create work material.

Bias and ethics: All AI systems are subject to the bias of the underlying training materials. All AI produced work must be reviewed for unintended or undesirable instances of bias.

Accuracy: Double check all AI produced content for accuracy. Math can be done incorrectly, and AI Tools can generate incorrect facts, computational results and references. They must be checked for accuracy before publishing. If a reliable source cannot be found to verify factual information, that information cannot be used for County purposes.

Copyright: There is a significant risk of inadvertently using copyrighted material when AI is used to produce a document or other written material. The results may include copyrighted material; users should make sure AI-produced content is appropriately used and properly attributed with citations as necessary.

Human Oversight: County employees remain responsible for all final work product regardless of the level of AI assistance used in its development. AI Tools are intended to assist County personnel and shall not independently make final governmental, legal, personnel, procurement, financial, enforcement, or policy decisions without appropriate human review and authorization.

Training: All County employees with an email or computer account are required to complete basic AI training annually. Users may opt for additional training sessions to deepen their understanding and skills.

6. MEETING ATTENDANT AI TOOLS

Meeting attendant AI Tools allow an individual to invite an AI attendant to “attend” an online meeting. The attendant records audio from the meeting and transcribes the content, as well as creating a summary and can analyze tone and sentiment. An employee may not send an AI attendant to attend a meeting on their behalf.

Potential legal considerations associated with such use are noted below:

1. **Public Records Issues:** If all attendees of a County managed meeting agree, an AI attendant can be used to transcribe and summarize the meeting. However, this creates a public record of the meeting and trains the AI on the content of the meeting that needs to be kept in accordance with the County Records Retention Policy.
2. **Sensitive or protected data:** Sensitive and protected data may not be used with AI Tools, including discussions of such information while an AI meeting attendant is present due to recording and transcription.
3. **Third-party initiated meetings:** If a County authorized user is attending a meeting scheduled and managed by a third party, the use of an AI assistant is the third party’s prerogative. If a department or employee is reluctant to attend the meeting with the AI assistant, then a request should be sent to the meeting host to have it removed. Please be aware that this type of record becomes the property of the 3rd party and is subject to their retention and disclosure requirements.

7. ACQUISITION OF AI TECHNOLOGY

Consistent with County standards for Technology Procurement, referenced in the Computer Use Policy, County authorized users may use recommended AI Tools or may request acquisition of AI Tools through the standard procurement process. The County’s standard for technology procurement applies to all technology, including free-to-use tools or software-as-a-service tools. The County will not pay for or reimburse authorized users for premium subscriptions or other costs associated with AI Tools without prior approval.

8. MONITORING AI TOOL USAGE:

In alignment with the Privacy section of the Computer Use Policy, Brazos County may monitor the usage of AI Tools by employees on County resources to ensure compliance. . This extends to both private and County owned AI Tool accounts. Any usage by County owned accounts can be subject to review and disclosure, regardless of whether that usage occurs on County information resources.

9. PROHIBITED USES

AI Tools will not be used to:

- Violate laws, regulations, or organizational policies.
 - Generate, distribute, or support discriminatory, fraudulent, improper, or misleading content.
 - Compromise physical or cyber security, violate privacy, or circumvent any established Brazos County policy.
 - Violate any local, state, or federal statutes.
-

10. VIOLATIONS

All potential violations will be evaluated on a case by case basis and failure to follow the usage standards set by the County shall make an employee subject to disciplinary action, up to and including termination. Any non-employee authorized user found in violation of the requirements established in this policy will risk having access to County Information Resources revoked. Violations made by a third party while operating an AI Tool on behalf of Brazos County may result in a breach of contract and/or pursuit of damages. If Brazos County authorized users become aware that AI Tools have been used in any of the above prohibited uses or that the AI caused harm, they must report the instance to their supervisor and the Chief Information Security Officer (CISO).

11. PROHIBITION OF CERTAIN AI TOOLS

Some AI Tools are prohibited from use for official County purposes. AI Tools meeting any of the following criteria will be prohibited:

- AI Tools created or managed by companies that cooperate with hostile agencies, including but not limited to foreign adversaries, cybercrime organizations and terrorist organizations.
- AI Tools created or managed by companies that have demonstrated a significant lack of concern for user security and privacy.
- AI Tools that are prohibited by state or federal statute, even if not specifically mentioned on the page referenced below.

The following SharePoint site will have a list of Recommended and Prohibited AI Tools:
[Recommended and Prohibited AI Tools](#)

The CISO or designee may add AI Tools to this list at their discretion. Reasons for prohibiting an AI Tool will be documented. The list of recommended and prohibited AI Tools will be reviewed by the committee during the annual review.

12. BASIC RULES FOR AI USAGE

A. SECURITY AND PRIVACY

- **Protect Confidentiality:** Avoid inputting any sensitive or personally identifiable information (PII) into AI Tools, especially data related to County employees or residents.
 - **Data Sensitivity Awareness:** Be mindful of sensitive information, such as demographic data, and consider implications to prevent unintended bias.
-

- **Cloud Data Security:** Use government-authorized cloud platforms for AI-related data storage, with vendor audits when public tenants are required.
- **Obfuscate Brazos County:** During the creation of work using AI, use “Sample County” instead of “Brazos”. This will prevent the AI from learning, reusing or inferring based on unfinished or unapproved work.

B. BIAS AND ETHICS

- **Content Review for Bias:** Carefully review AI outputs to identify any unintended biases that may arise from source materials.
- **Ethics of AI Use:** Uphold principles of transparency, accountability, and fairness by reviewing content for ethical concerns.

C. ACCURACY

- **Verify AI Content:** Check AI-generated content for accuracy, using primary sources as needed, especially in official County communications.
- **Continuous Testing:** Implement regular monitoring and model updates to ensure accuracy and prevent drift over time.

D. COPYRIGHT

- **Respect Copyrights:** Monitor AI content to avoid using copyrighted material inappropriately, providing attribution as needed.

E. ACCOUNTABILITY AND TRANSPARENCY

- **Use Official Accounts:** Use designated County accounts for all County-related AI activities to maintain oversight. Accounts created using Brazos County email addresses will be considered County owned and should be kept separate from personal AI tool usage.
- **Feedback Mechanisms:** Encourage feedback on AI-generated responses to improve quality and address concerns promptly.
- **Public Information Act Alignment:** All user inputs into an AI system and any output from an AI system may be subject to Texas Government Code 552 – Public Information Act and may be requested by the public.

F. INNOVATION WITH AI TOOLS

- To foster creativity and innovation, employees are encouraged to explore approved AI tools within the guidelines of this policy. A structured process will be established for proposing new AI tools with potential benefits to the County."

G. EMPLOYEE FEEDBACK

- Employees are encouraged to provide feedback on this policy and its implementation.



**BRAZOS COUNTY
BRYAN, TEXAS**

DEPARTMENT: Budget Office NUMBER:

DATE OF COURT MEETING: 6/23/2026

ITEM: Request from Forensic Services - Administration for the following personnel changes with the effective date as of June 27, 2026. This change will increase the Forensic Services - Administration FY 2026 Budget in the amount of \$24,025.00.

- a. Increase B3004-1 Forensic Lab Technician, Salary Grade B3004-1, from \$0.00 per hour to \$28.26 per hour, Hourly Full-Time

TO: Commissioners Court

FROM: Nina Payne

DATE: 06/11/2026

FISCAL IMPACT: True

BUDGETED: False

DOLLAR AMOUNT: \$24,025.00

BUDGET DETAIL: General Fund Contingency (Fund 01000)

ACTION REQUESTED OR ALTERNATIVES: Request approval.



**BRAZOS COUNTY
BRYAN, TEXAS**

DEPARTMENT: Budget Office NUMBER:
DATE OF COURT MEETING: 6/23/2026
ITEM: Request from Forensic Services - Administration for the following personnel changes with the effective date as of June 27, 2026. This change will increase the Forensic Services - Administration FY 2026 Budget in the amount of \$24,025.00.
• a. Increase B3004-1 Forensic Lab Technician, Salary Grade B3004-1, from \$0.00 per hour to \$28.26 per hour, Hourly Full-Time
TO: Commissioners Court
FROM: Nina Payne
DATE: 06/11/2026
FISCAL IMPACT: True
BUDGETED: False
DOLLAR AMOUNT: \$24,025.00
BUDGET DETAIL: General Fund Contingency (Fund 01000)
ACTION REQUESTED OR ALTERNATIVES: Request approval.

ATTACHMENTS:

<u>File Name</u>	<u>Description</u>	<u>Type</u>
Foresnic_Services__6.23.26.pdf	Personnel Change Calculations	Backup Material

APPROVED

Duane Peters
County Judge
6/23/26
Date



**BRAZOS COUNTY
BRYAN, TEXAS**

DEPARTMENT: Risk Management

NUMBER:

DATE OF COURT MEETING: 6/23/2026

ITEM: Approval of the following liability renewal questionnaire for Texas Association of Counties with coverage dates of October 1, 2026 - October 1, 2027.

- a. Auto Liability
- b. Auto Physical Damage
- c. General Liability
- d. Public Officials Liability
- e. Law Enforcement Liability

TO: Commissioners Court

FROM: Leslie Contreras

DATE: 06/12/2026

FISCAL IMPACT: False

BUDGETED: False

DOLLAR AMOUNT: \$0.00

NOTES/EXCEPTIONS: **Background Information:** Risk Management is requesting approval for the renewal of the County's general liability policies. This policy, administered by Risk Management, covers *Law Enforcement Liability, Public Official Liability, Auto liability and Auto Physical Damage*. Texas Association of Counties (TAC) is a Risk Management Pool allowed by state statute where Texas Counties pool their funds for the services and coverages.

Essentially it acts as self-insurance, but TAC manages all the claims and claims processes on the County's behalf.

TAC also provides an abundance of other services that normal insurance agencies would not, such as in-person training for employees to reduce risk, sample policies, in-person trainings for law enforcement specific trainings. TAC also provides safety inspections of buildings, drone inspections for exterior of the buildings, free conferences for staff and elected officials to get the most up-to-date information on liability, safety and HR related issues.

Purpose: The renewal of this policy is an annual expense that helps transfer risk associated with lawsuits and damages that any County employee cause as well as vehicle crashes and other potential risks that could affect the County.

Impact: If this renewal is not approved, it will leave Brazos County without insurance coverage on *Law Enforcement Liability, Public Official Liability; Auto liability and Auto Physical Damage*. This will put the County at financial and operational risk in the event of a lawsuit, loss or damage.

Deadline: Timely approval is necessary to ensure uninterrupted coverage for the upcoming year.

Budget: Considered as self-insurance. Budget is available in Commissioners' Court - Non-Departmental Budget - In past years Brazos County has pooled approx. \$500,000 specifically for this coverage. This application will allow TAC to give us the amount that will need to be funded in the pool for the program.



**BRAZOS COUNTY
BRYAN, TEXAS**

DEPARTMENT: Human Resources NUMBER:
DATE OF COURT MEETING: 6/23/2026
ITEM: • Approval of Personnel Change of Status.
TO: Commissioners Court
DATE: 06/15/2026
FISCAL IMPACT: False
BUDGETED: False
DOLLAR AMOUNT: \$0.00

REQUIREMENTS: Human Resources is requesting the approval of the following Personnel Action Forms (PAFs). A list of departments is included on the attached coversheet. All positions have been reviewed and verified that they fall within budget guidelines. Consequence of non-approval would be to the employee pay and/or position.

ATTACHMENTS:

<u>File Name</u>	<u>Description</u>	<u>Type</u>
Cover_Sheet.pdf	Cover Sheet	Cover Memo

Personnel Change of Status

(Jun 15, 2026)

Commissioners' Court Date: 06-16-2026
 Department Submitting Information: Human Resources
 Purpose of Submissions: Consider and Take Action on Change

Employment

Department Name	Employee Name
Exposition Center - Administration	Haley, Timothy

Separations

Department Name	Employee Name
Human Resources - Administration	Maldonado, Ashlynn

Personnel Change of Status

Department Name	Employee Name
Juvenile Services - Administration Probation	Flores, Melanie
Juvenile Services - Detention	Curtis, Claude
Juvenile Services - Detention	Foster, Lawyer
Juvenile Services - Detention	Gibson, Latoria
Juvenile Services - Detention	Ibarra, Sinai
Juvenile Services - Detention	Jackson, Jada
Juvenile Services - Detention	Johnson, Reginald
Juvenile Services - Detention	Lewis, Renee
Juvenile Services - Detention	Martinez, Angel
Juvenile Services - Detention	Massie, MyKeisha
Juvenile Services - Detention	Posival, Jason
Juvenile Services - Detention	Ragston, Denisha
Juvenile Services - Detention	Rice, Tahj
Juvenile Services - Detention	Rojas, Arely
Juvenile Services - Detention	Romero, Jessica
Juvenile Services - Detention	Vasquez, Gabriela
Juvenile Services - Detention	Walker, Jeremy
Juvenile Services - TJJD Pre & Post Adjudication	Sanchez, Jacqueline
Juvenile Services - TJJD Pre & Post Adjudication	Vela, John

Approved in Commissioners' Court:

County Judge's or Commissioner's Signature:

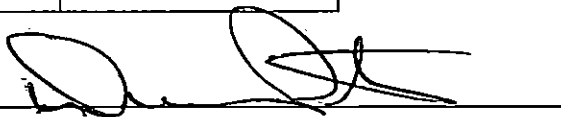



**BRAZOS COUNTY
BRYAN, TEXAS**

DEPARTMENT:

NUMBER:

DATE OF COURT MEETING: 6/23/2026

ITEM: • Approval of Payments of Claims.

TO: Commissioners Court

DATE: 06/16/2026

FISCAL IMPACT: False

BUDGETED: False

DOLLAR AMOUNT: \$0.00

ATTACHMENTS:

File Name

Description

Type

[Bill_List_Commissioners_Court_PUBLIC_06.23.26.pdf](#) Bill List Public

Cover Memo



Commissioners Court Approval of Claims Summary

June 23, 2026

Accounts Payable

Payment Date	Amount	Beginning	Ending	Type
6/3/2026	\$ 22,133.83	8216036	8216043	Payroll AP
6/4/2026	\$ 12,245.76	8216044	8216055	Utilities, Credit Card Bills, Refunds
6/4/2026	\$ 31,206.39	8216056	8216058	Restitution
6/11/2026	\$ 58,178.57	8216059	8216068	Utilities, Credit Card Bills, Refunds
6/11/2026	\$ 5,078.68	8216069	8216100	Restitution
6/23/2026	\$ 1,544,607.03	8216101	8216274	AP
6/3/2026	\$ 4,322.50	9207982	9207985	Payroll AP
6/4/2026	\$ 4,274.08	9207986	9207988	Travel Advance
6/4/2026	\$ 3,467.53	9207989	9207991	Utilities, Credit Card Bills, Refunds
6/11/2026	\$ 8,020.72	9207992	9207999	Travel Advance
6/11/2026	\$ 10,411.33	9208000	9208002	Utilities, Credit Card Bills, Refunds
6/23/2026	\$ 6,490,338.52	9208003	9208095	AP

Jury

Payment Date	Amount
6/4/2026	\$ 260.00
6/11/2026	\$ 5,192.00

Payroll

Payment Date	Amount	Type
6/12/2026	\$ 2,094,477.43	Biweekly

Wire/ TexNet

Payment Date	Amount	Number	Description
6/3/2026	\$ 61.60	2026-95	Payroll Taxes
6/3/2026	\$ 919.07	2026-96	Sales Tax
6/12/2026	\$ 15,888,580.36	2026-97	LPPF
6/12/2026	\$ 701,779.47	2026-98	Payroll Taxes

Pursuant to Order 25-027 certain claims are approved for payment by the Commissioners Court if approved through the audit process. Payments are then presented to Commissioners Court at a subsequent meeting. These include Payroll and payroll related claims, utilities and telecommunications services, and credit card bills.

ATTEST:

 Karen McQueen
 County Clerk

APPROVED:

 Duane Peters
 County Judge

6/23/26
 Date

Bill List Commissioners Court

Time run: 6/16/2026 9:57:18 AM

Payment Date 6/3/2026

Payment Date	Account	Account Description	Supplier Number	Party Name	PO	In
6/3/2026	60000-00000000-31120000-00000-0000-0000000	Payroll Fund-No Value-Deferred Compensation \- Nationwide-No Value-No Value-No Value	3382	Natio***** Solutions		Pa 05
	60000-00000000-31125000-00000-0000-0000000	Payroll Fund-No Value-Deferred Compensation \- Secur Benefit-No Value-No Value-No Value	6165	Secur***** Insurance Co		05
	60000-00000000-31128000-00000-0000-0000000	Payroll Fund-No Value-Deferred Compensation \- VALIC-No Value-No Value-No Value	10789	Varia***** Insurance Co Inc		05
	60000-00000000-31200000-00000-0000-0000000	Payroll Fund-No Value-Withholding \- Child Support-No Value-No Value-No Value	103711	North*****Support Centralized Collections		05
	60000-00000000-31204100-00000-0000-0000000	Payroll Fund-No Value-Withholding \- Child Care-No Value-No Value-No Value	101387	Peder*****		DC ZF
			103597	Corre*****		DC
	60000-00000000-31204200-00000-0000-0000000	Payroll Fund-No Value-Withholding \- Unreimb. Medical-No Value-No Value-No Value	103618	Kawos*****		FS
	60000-00000000-31228000-00000-0000-0000000	Payroll Fund-No Value-Withholding \- Hartford\AD&D-No Value-No Value-No Value	6874	Hartf***** , The		23
	60000-00000000-31236000-00000-0000-0000000	Payroll Fund-No Value-Withholding \- Consec\ -Cancer Ins-No Value-No Value-No Value	3436	WILCA***** Company		02
	60000-00000000-31237000-00000-0000-0000000	Payroll Fund-No Value-Withholding \- Colonial Insurance-No Value-No Value-No Value	10372	Colon*****ent Insurance Company		74
	60000-00000000-31240000-00000-0000-0000000	Payroll Fund-No Value-Withholding \- AFLAC Insurance-No Value-No Value-No Value	3428	Ameri*****Insurance		90

Payment Date	Account	Account Description	Supplier Number	Party Name	PO	ln
6/3/2026	60000-00000000-31600000-00000-0000-000000	Payroll Fund-No Value-Withholding \- United Way-No Value-No Value-No Value	3395	Unite*****zos Valley		05
Grand Total						

Payment Date 6/4/2026

Payment Date	Account	Account Description	Supplier Number	Party Name	PO
6/4/2026	01000-00000000-20000100-00000-0000-000000	General Fund-No Value-Cash Advance \- Subledger Total-No Value-No Value-No Value	Employee	Brand*****ts	
				Kryst*****	
				Nicho*****	
	01000-00000000-30340000-00000-0000-000000	General Fund-No Value-Deposits Payable \- Brazos Center-No Value-No Value-No Value	103797 103798	Herre*****fund	
				BCS N*****ning Center - Refund	
	01000-00000000-37290000-00000-0000-000000	General Fund-No Value-Funds Held in Trust \- Coupon Surety Fee-No Value-No Value-No Value	11803	Aggie*****	
21434				Brazo*****nds	
90337				Gage*****	

Payment Date	Account	Account Description	Supplier Number	Party Name	PO
6/4/2026	01000-00000000-37290000-00000-0000-000000	General Fund-No Value-Funds Held in Trust \- Coupon Surety Fee-No Value-No Value-No Value	90337	Gage*****	
	01000-10000100-61280000-00000-0000-000000	General Fund-County Judge \- Administration-Dues-No Value-No Value-No Value	93466	US Ba*****ciation Inc	2600
	01000-11000500-61880000-00000-0000-000000	General Fund-Non\-Departmental-Utilities Expenditure-No Value-No Value-No Value	20	Bryan*****	2600 2600 2600
	01000-14000006-61880000-00000-0000-000000	General Fund-Information Technology \- Non Capital-Utilities Expenditure-No Value-No Value-No Value	102101	Fiber*****	2600
	01000-15000100-60600000-00000-0000-000000	General Fund-Human Resources \- Administration-Office Supplies-No Value-No Value-No Value	93466	US Ba*****ciation Inc	2600
	01000-15000100-61235000-00000-0000-000000	General Fund-Human Resources \- Administration-Donations \- Other-No Value-No Value-No Value	93466	US Ba*****ciation Inc	2600
	01000-19000100-61890000-00000-0000-000000	General Fund-District Attorney \- Administration-Victim Assistance-No Value-No Value-No Value	93466	US Ba*****ciation Inc	2600
	01000-24201100-61750000-00000-0000-000000	General Fund-Justice of Peace \- Precinct 2 \- Administration-Telephone/Data \- Cellular-No Value-No Value-No Value	97548	Veriz*****	2600
	01000-28000100-61110000-00000-0000-000000	General Fund-Sheriff Office \- Administration-Conference & Seminar Fees-No Value-No Value-No Value	93466	US Ba*****ciation Inc	2600 2600
	01000-28000100-61280000-00000-0000-000000	General Fund-Sheriff Office \- Administration-Dues-No Value-No Value-No Value	93466	US Ba*****ciation Inc	2600
	01000-28000100-61880000-00000-0000-000000	General Fund-Sheriff Office \- Administration-Utilities Expenditure-No Value-No Value-No Value	97206	Optim*****	2600
	01000-28002000-61806000-00000-0000-000000	General Fund-Sheriff Office \- Jail Administration-Travel \- Inmate Transport-No Value-No Value-No Value	93466	US Ba*****ciation Inc	2600 2600
	01000-35500100-61740000-00000-0000-000000	General Fund-Emergency Management \- Administration-Telephone-No Value-No Value-	97251	Texas*****	2600

Payment Date	Account	Account Description	Supplier Number	Party Name	PO
6/4/2026		No Value			
	01000-56005000-61740000-00000-0000-000000	General Fund-Environmental Protection-Telephone-No Value-No Value-No Value	101833	Brigh*****	2600
	01000-56005000-61880000-00000-0000-000000	General Fund-Environmental Protection-Utilities Expenditure-No Value-No Value-No Value	20	Bryan*****	2600 2600
	13000-00000000-30999000-00000-0000-000000	Unclaimed Property Fund-No Value-Unclaimed Funds-No Value-No Value-No Value	103759	Unive*****any Inc - Refund	
			103795	Cisne***** Refund	
	33000-28050000-60350000-00000-0000-000000	Sheriff's Office Crime Fund-Sheriff Office \- Crime Fund-Food and Food Supplements-No Value-No Value-No Value	93466	US Ba*****ciation Inc	2600
	91000-53000100-61880000-00000-0000-000000	Health \- County Health District-Health Department \- Administration-Utilities Expenditure-No Value-No Value-No Value	97206	Optim*****	2600
	91000-53001000-61110000-00000-0000-000000	Health \- County Health District-Environmental Services Administration-Conference & Seminar Fees-No Value-No Value-No Value	93466	US Ba*****ciation Inc	2600
	97000-551100-69304000-00000-0000-000000	CSCD \- Community Supervision-Basic Supervision-Licenses & Memberships-No Value-No Value-No Value	93466	US Ba*****ciation Inc	2600
	97000-551100-69308000-00000-0000-000000	CSCD \- Community Supervision-Basic Supervision-Professional Fees \- Other \- CSCD-No Value-No Value-No Value	93466	US Ba*****ciation Inc	2600
Grand Total					

Payment Date 6/11/2026

Payment Date	Account	Account Description	Supplier Number	Party Name	PO
6/11/2026	01000-00000000-20000100-00000-0000-000000	General Fund-No Value-Cash Advance ↳ Subledger Total-No Value-No Value- No Value	Employee	Angel*****	
				Bart *****	
				Charl*****er	
				David*****	
				Loura*****	
				Mindy*****	
				Natha*****	
Paul *****					
	01000-00000000-30340000-00000-0000-000000	General Fund-No Value-Deposits Payable ↳ Brazos Center-No Value-No Value-No Value	103812	Orteg*****	
	01000-00000000-37200000-00000-0000-000000	General Fund-No Value-Deferred Revenue ↳ Collections-No Value-No Value-No Value	103551	Gonza*****efund	
	01000-00000000-37290000-00000-0000-000000	General Fund-No Value-Funds Held in Trust ↳ Coupon Surety Fee-No Value- No Value-No Value	11803	Aggie*****	
90337			Gage*****		

Payment Date	Account	Account Description	Supplier Number	Party Name	PO
6/11/2026	01000-00000000-37290000-00000-0000-000000	General Fund-No Value-Funds Held in Trust \- Coupon Surety Fee-No Value-No Value-No Value	90337	Gage *****	
	01000-10000100-61080000-00000-0000-000000	General Fund-County Judge \- Administration-Community Relations-No Value-No Value-No Value	93466	US Ba*****ciation Inc	260003:
	01000-11000500-61740000-00000-0000-000000	General Fund-Non\Departmental-Telephone-No Value-No Value-No Value	96844	Front*****ns of Texas	260000:
	01000-11000500-61880000-00000-0000-000000	General Fund-Non\Departmental-Utilities Expenditure-No Value-No Value	20	Bryan*****	260000:
					260000:
			60	Atmos*****	260000:
					260000:
	01000-11020000-61020000-00000-0000-000000	General Fund-Court Support \- Civil-Autopsy-No Value-No Value-No Value	90303	Hilli*****	
	01000-11210020-61740000-00000-0000-000000	General Fund-Elections Administrator-Telephone-No Value-No Value-No Value	96844	Front*****ns of Texas	260000:
	01000-11210020-61880000-00000-0000-000000	General Fund-Elections Administrator-Utilities Expenditure-No Value-No Value-No Value	20	Bryan*****	260000:
	01000-14000006-61880000-00000-0000-000000	General Fund-Information Technology \- Non Capital-Utilities Expenditure-No Value-No Value-No Value	96844	Front*****ns of Texas	260000:
	01000-14000006-65150000-00000-0000-000000	General Fund-Information Technology \- Non Capital-Computer Maintenance-No Value-No Value-No Value	93466	US Ba*****ciation Inc	260003:
	01000-14000100-61680000-00000-0000-000000	General Fund-Information Technology \- Administration-Training-No Value-No Value	93466	US Ba*****ciation Inc	260003:
	01000-14000100-61880000-00000-0000-000000	General Fund-Information Technology \- Administration-Utilities Expenditure-No Value-No Value-No Value	20	Bryan*****	260000:
				60	Atmos*****
	01000-17000100-61740000-00000-0000-000000	General Fund-Facilities Services \- Administration-Telephone-No Value-No Value	96844	Front*****ns of Texas	260000:
	01000-17000100-61880000-00000-0000-000000	General Fund-Facilities Services \- Administration-Utilities Expenditure-No Value-No Value-No Value	20	Bryan*****	260000:
	01000-17000300-61880000-00000-0000-000000	General Fund-Facilities Services \- Parking Garage-Utilities Expenditure-No Value-No Value-No Value	20	Bryan*****	260000:
					260000:
	01000-19000100-61210000-00000-0000-000000	General Fund-District Attorney \- Administration-Court Costs-No Value-No Value	93466	US Ba*****ciation Inc	260003:
	01000-19000100-61280000-00000-0000-000000	General Fund-District Attorney \- Administration-Dues-No Value-No	93466	US Ba*****ciation Inc	260003:

Payment Date	Account	Account Description	Supplier Number	Party Name	PO
6/11/2026		Value-No Value			
	01000-19000100-61801000-00000-0000-000000	General Fund-District Attorney \- Administration-Travel-No Value-No Value-No Value	93466	US Ba*****ciation Inc	260003!
	01000-22000100-60600000-00000-0000-000000	General Fund-85th District Court \- Administration-Office Supplies-No Value-No Value-No Value	395	Penga*****	260002!
	01000-24301100-61740000-00000-0000-000000	General Fund-Justice of Peace \- Precinct 3 \- Administration-Telephone-No Value-No Value-No Value	96844	Front*****ns of Texas	260000!
	01000-26001000-61740000-00000-0000-000000	General Fund-Community Supervision \- Support-Telephone-No Value-No Value-No Value	96844	Front*****ns of Texas	260000!
	01000-26001000-61880000-00000-0000-000000	General Fund-Community Supervision \- Support-Utilities Expenditure-No Value-No Value-No Value	20	Bryan*****	260000!
	01000-26002000-61740000-00000-0000-000000	General Fund-Health Department \- Support-Telephone-No Value-No Value-No Value	96844	Front*****ns of Texas	260000!
	01000-28000100-61740000-00000-0000-000000	General Fund-Sheriff Office \- Administration-Telephone-No Value-No Value-No Value	96844	Front*****ns of Texas	260000!
	01000-28000100-61880000-00000-0000-000000	General Fund-Sheriff Office \- Administration-Utilities Expenditure-No Value-No Value-No Value	60	Atmos*****	260000!
	01000-28002000-61880000-00000-0000-000000	General Fund-Sheriff Office \- Jail Administration-Utilities Expenditure-No Value-No Value-No Value	60	Atmos*****	260000! 260000! 260000!
	01000-31000110-61740000-00000-0000-000000	General Fund-Juvenile Services \- Administration Court-Telephone-No Value-No Value-No Value	96844	Front*****ns of Texas	260000!
	01000-31000220-61880000-00000-0000-000000	General Fund-Juvenile Services \- Detention-Utilities Expenditure-No Value-No Value-No Value	60	Atmos*****	260000!
	01000-35500100-61801000-00000-0000-000000	General Fund-Emergency Management \- Administration-Travel-No Value-No Value-No Value	93466	US Ba*****ciation Inc	260004! 260004! 260004!
	01000-36500100-61740000-00000-0000-000000	General Fund-Brazos Center \- Administration-Telephone-No Value-No Value-No Value	96844	Front*****ns of Texas	260000!
	01000-56001000-61740000-00000-0000-000000	General Fund-Road & Bridge \- Administration-Telephone-No Value-No Value-No Value	96844	Front*****ns of Texas	260000!
	01000-56001000-61880000-00000-0000-000000	General Fund-Road & Bridge \- Administration-Utilities Expenditure-No Value-No Value-No Value	20 60	Bryan***** Atmos*****	260000! 260000!
	01000-56002000-65320000-00000-0000-000000	General Fund-Fleet Shop \- Heavy Equipment-Equipment Maintenance-No Value-No Value-No Value	96270	Asco *****	260002!

Payment Date	Account	Account Description	Supplier Number	Party Name	PO
6/11/2026	01000-56005000-61740000-00000-0000-000000	General Fund-Environmental Protection-Telephone-No Value-No Value-No Value	96844	Front*****ns of Texas	260000:
	30000-424100-61740000-00000-0000-000000	Brazos County Grant Fund-Metropolitan Planning \- Administration-Telephone-No Value-No Value-No Value	96672	Itech*****	260000:
	30000-424100-71506000-00000-0000-000000	Brazos County Grant Fund-Metropolitan Planning \- Administration-Rental \- Office Space-No Value-No Value-No Value	97482	Fores*****	260000:
	50000-64005100-61740000-00000-0000-000000	Health and Life Insurance Fund-Health & Wellness Clinic-Telephone-No Value-No Value-No Value	96844	Front*****ns of Texas	260000:
	50000-64005100-61880000-00000-0000-000000	Health and Life Insurance Fund-Health & Wellness Clinic-Utilities Expenditure-No Value-No Value-No Value	20	Bryan*****	260000:
	91000-53000100-61280000-00000-0000-000000	Health \- County Health District-Health Department \- Administration-Dues-No Value-No Value-No Value	93466	US Ba*****ciation Inc	260003:
	97000-551100-69308000-00000-0000-000000	CSCD \- Community Supervision-Basic Supervision-Professional Fees \- Other\CSCD-No Value-No Value-No Value	93466	US Ba*****ciation Inc	260003:
Grand Total					

Payment Date 6/23/2026

Payment Date	Account	Account Description	Supplier Number	Party Name
6/23/2026	01000-00000000-26910000-00000-0000-000000	General Fund-No Value-Prepaid Insurance-No Value-No Value-No Value	6313	Texas*****Counties
	01000-00000000-26940000-00000-0000-000000	General Fund-No Value-Prepaid Conference and Seminars-No Value-No Value-No Value	19936	Texas***** Court Administration
	01000-00000000-26941000-00000-0000-000000	General Fund-No Value-Prepaid Department Support-No Value-No Value-No Value	90208	CNA S*****
	01000-00000000-30009400-00000-0000-000000	General Fund-No Value-A/P Tax \- McCreary Veselka-No Value-No Value-No Value	19432	McCre*****g & Allen
	01000-00000000-30011000-00000-0000-000000	General Fund-No Value-A/P Appellate Judicial System Fund-No Value-No Value-No Value	101413	Tenth*****s
	01000-00000000-30019000-00000-0000-000000	General Fund-No Value-A/P Alternative Dispute Resolution Fund-No Value-No Value-No Value	9756	Dispu*****nter - Brazos Valley
	01000-00000000-30024100-00000-0000-000000	General Fund-No Value-A/P DSHS \- Birth Fees-No Value-No Value-No Value	16569	Texas*****tate Health Services
	01000-00000000-30074000-00000-0000-000000	General Fund-No Value-A/P TAMU Police Dept (Arr Fees)-No Value-No Value-No Value	97251	Texas*****
	01000-00000000-30090000-00000-0000-000000	General Fund-No Value-A/P Executions Pending-No Value-No Value-No Value	103810 103811	Sills***** Zhang*****
	01000-00000000-30302000-00000-0000-000000	General Fund-No Value-Contract Pay \- Retainages-No Value-No Value-No Value	102695	Solid*****tion
	01000-00000000-37012000-00000-0000-000000	General Fund-No Value-Deferred Revenue Justice of the Peace 2-No Value-No Value-No Value	103006	Klebe*****
	01000-10000100-65540000-00000-0000-000000	General Fund-County Judge \- Administration-Copier/Printer/Fax Maintenance-No Value-No Value-No Value	9038	Xerox*****ons Southwest
	01000-10002000-60080000-00000-0000-000000	General Fund-Veteran Services-Clothing/Uniforms-No Value-No Value-No Value	91345	CC Cr*****
	01000-10002000-60170000-00000-0000-000000	General Fund-Veteran Services-Copier/Printer/Fax Supplies-No Value-No Value-No Value	94806	Perry
	01000-10002000-60600000-00000-0000-000000	General Fund-Veteran Services-Office Supplies-No Value-No Value-No Value	94806	Perry
	01000-10002000-61500000-00000-0000-000000	General Fund-Veteran Services-Printing-No Value-No Value-No Value	1229	Alpha*****

Payment Date	Account	Account Description	Supplier Number	Party Name
6/23/2026	01000-10002000-61500000-00000-0000-000000	General Fund-Veteran Services-Printing-No Value-No Value-No Value	1229	Alpha*****
	01000-10002000-61801000-00000-0000-000000	General Fund-Veteran Services-Travel-No Value-No Value-No Value	Employee	Diana***** Kale *****
	01000-10002000-65540000-00000-0000-000000	General Fund-Veteran Services-Copier/Printer/Fax Maintenance-No Value-No Value-No Value	9038	Xerox*****ons Southwest
	01000-11000100-65540000-00000-0000-000000	General Fund-Commissioners Court \-Administration-Copier/Printer/Fax Maintenance-No Value-No Value-No Value	9038	Xerox*****ons Southwest
	01000-11000500-60620000-00000-0000-000000	General Fund-Non\-Departmental-Postage & Shipping-No Value-No Value-No Value	1055	FedEx*****
			126	US Po*****
	01000-11000500-61400000-00000-0000-000000	General Fund-Non\-Departmental-Insurance-No Value-No Value-No Value	6313	Texas*****Counties
	01000-11000500-71025000-00000-0000-000000	General Fund-Non\-Departmental-Contract Services-No Value-No Value-No Value	97251	Texas*****
	01000-11000500-72070000-00000-0000-000000	General Fund-Non\-Departmental-Attorneys-No Value-No Value-No Value	92284	Germe*****
			94447	West ***** & Gentry Inc
	01000-11001000-65050000-00000-0000-000000	General Fund-Boonville Cemetery-Building Maintenance-No Value-No Value-No Value	103065	White*****tion LLC
	01000-11002000-73030000-00000-0000-000000	General Fund-Community Support-Boys & Girls Club Of Brazos Valley-No Value-No Value-No Value	9750	Boys *****of the Brazos Valley
	01000-11002000-73120000-00000-0000-000000	General Fund-Community Support-Brazos Animal Shelter-No Value-No Value-No Value	938	Aggie*****ety
	01000-11002000-73420000-00000-0000-000000	General Fund-Community Support-Brazos Valley Economic Development Cor-No Value-No Value-No Value	7130	Great*****rship
	01000-11010000-61210000-00000-0000-000000	General Fund-Court Support \-Criminal-Court Costs-No Value-No Value-No Value	103004	Marti*****
01000-11010000-72070000-00000-1102-000000	General Fund-Court Support \-Criminal-Attorneys-No Value-Adult Felony-No Value	800687	Shime*****	
01000-11010000-72201000-00000-1104-000000	General Fund-Court Support \-Criminal-Court Appointed Attorneys \-County Court at Law #1-No Value-Adult Misdemeanor-No Value	100000	Law O*****Andreski, PC	

Payment Date	Account	Account Description	Supplier Number	Party Name
6/23/2026	01000-11010000-72201000-00000-1104-000000	General Fund-Court Support \- Criminal-Court Appointed Attorneys \- County Court at Law #1-No Value- Adult Misdemeanor-No Value	101451	Navar*****mey at Law
			102584	The M*****
			103295	Rodri*****LLC
			103383	Marit*****varria Law
			103540	The W*****LC
			802205	Cune,*****
			95315	Law O*****Maltsberger
			95611	Law O*****helps, PC, The
			97200	Barto*****
				01000-11010000-72201300-00000-1104-000000
	01000-11010000-72202000-00000-1102-000000	General Fund-Court Support \- Criminal-Court Appointed Attorneys \- County Court at Law #2-No Value- Adult Felony-No Value	103295	Rodri*****LLC
97200			Barto*****	
	01000-11010000-72202000-00000-1104-000000	General Fund-Court Support \- Criminal-Court Appointed Attorneys \- County Court at Law #2-No Value- Adult Misdemeanor-No Value	100000	Law O*****Andreski, PC
101451			Navar*****mey at Law	
102584			The M*****	
103295			Rodri*****LLC	

Payment Date	Account	Account Description	Supplier Number	Party Name
6/23/2026	01000-11010000-72202000-00000-1104-000000	General Fund-Court Support \- Criminal-Court Appointed Attorneys \- County Court at Law #2-No Value-Adult Misdemeanor-No Value	103295	Rodri*****LLC
			103383	Marit*****varria Law
			103476	Thoma*****
			801423	Davis*****
			802205	Cune,*****
			91523	Herna*****
			95315	Law O*****Maltsberger
			95611	Law O*****helps, PC, The
			97200	Barto*****
				01000-11010000-72203000-00000-1102-000000
			97200	Barto*****
	01000-11010000-72203000-00000-1104-000000	General Fund-Court Support \- Criminal-Court Appointed Attorneys \- Preindictment/Dismissal-No Value-Adult Misdemeanor-No Value	91523	Herna*****
	01000-11010000-72204000-00000-1100-000000	General Fund-Court Support \- Criminal-Court Appointed Attorneys \- 472nd-No Value-Juvenile-No Value	801423	Davis*****
			95315	Law O*****Maltsberger
			96520	Thoma*****

Payment Date	Account	Account Description	Supplier Number	Party Name
6/23/2026	01000-11010000-72204000-00000-1100-000000	General Fund-Court Support \- Criminal-Court Appointed Attorneys \- 472nd-No Value-Juvenile-No Value	96520	Thoma*****
	01000-11010000-72205000-00000-1102-000000	General Fund-Court Support \- Criminal-Court Appointed Attorneys \- 85th-No Value-Adult Felony-No Value	100000	Law O*****Andreski, PC
			102584	The M*****
			102621	Law O*****Medina PLLC
			102828	Sarah*****LLC
			103295	Rodri*****LLC
			103787	James*****& Kleinschmidt
			801423	Davis*****
			805046	Gusti*****orney PLLC
			92302	Turnb*****PLLC
			95315	Law O*****Maltsberger
			95611	Law O*****helps, PC, The
			96368	Price*****
			96520	Thoma*****
			97200	Barto*****
	01000-11010000-72205000-00000-1104-000000	General Fund-Court Support \- Criminal-Court Appointed Attorneys \- 85th-No Value-Adult Misdemeanor-No Value	100000	Law O*****Andreski, PC
			102621	Law O*****Medina PLLC
			103295	Rodri*****LLC

Payment Date	Account	Account Description	Supplier Number	Party Name
6/23/2026	01000-11010000-72205000-00000-1104-000000	General Fund-Court Support \- Criminal-Court Appointed Attorneys \- 85th-No Value-Adult Misdemeanor-No Value	96368	Price*****
			96520	Thoma*****
			97200	Barto*****
	01000-11010000-72205100-00000-1102-000000	General Fund-Court Support \- Criminal-Investigator Fees \- 85th-No Value-Adult Felony-No Value	102828	Sarah*****LLC
	01000-11010000-72205200-00000-1102-000000	General Fund-Court Support \- Criminal-Expert Witness Fees \- 85th-No Value-Adult Felony-No Value	96520	Thoma*****
	01000-11010000-72205300-00000-1102-000000	General Fund-Court Support \- Criminal-Other Litigation Expenses \- 85th-No Value-Adult Felony-No Value	801423	Davis*****
	01000-11010000-72206000-00000-1102-000000	General Fund-Court Support \- Criminal-Court Appointed Attorneys \- 272nd-No Value-Adult Felony-No Value	100000	Law O*****Andreski, PC
			102584	The M*****
			103295	Rodri*****LLC
			103383	Marit*****varria Law
			103405	Spieg*****
			103787	James*****& Kleinschmidt
			800687	Shime*****
			801423	Davis*****
			92302	Turnb*****PLLC
			95315	Law O*****Maltsberger
	95611	Law O*****helps, PC, The		
96368	Price*****			
96520	Thoma*****			

Payment Date	Account	Account Description	Supplier Number	Party Name
6/23/2026	01000-11010000-72206000-00000-1102-000000	General Fund-Court Support \- Criminal-Court Appointed Attorneys \- 272nd-No Value-Adult Felony-No Value	97200	Barto*****
	01000-11010000-72206000-00000-1104-000000	General Fund-Court Support \- Criminal-Court Appointed Attorneys \- 272nd-No Value-Adult Misdemeanor- No Value	100000	Law O*****Andreski, PC
			102584	The M*****
			103295	Rodri*****LLC
			103405	Spieg*****
			800687	Shime*****
			801423	Davis*****
			92302	Turnb*****PLLC
			95611	Law O*****helps, PC, The
			96368	Price*****

Payment Date	Account	Account Description	Supplier Number	Party Name
6/23/2026	01000-11010000-72206000-00000-1104-000000	General Fund-Court Support \- Criminal-Court Appointed Attorneys \- 272nd-No Value-Adult Misdemeanor-No Value	96368	Price*****
			97200	Barto*****
	01000-11010000-72206100-00000-1102-000000	General Fund-Court Support \- Criminal-Investigator Fees \- 272nd-No Value-Adult Felony-No Value	95611	Law O*****helps, PC, The
	01000-11010000-72206200-00000-1102-000000	General Fund-Court Support \- Criminal-Expert Witness Fees \- 272nd-No Value-Adult Felony-No Value	95611	Law O*****helps, PC, The
	01000-11010000-72206300-00000-1102-000000	General Fund-Court Support \- Criminal-Other Litigation Expenses \- 272nd-No Value-Adult Felony-No Value	95611	Law O*****helps, PC, The
	01000-11010000-72207000-00000-1102-000000	General Fund-Court Support \- Criminal-Court Appointed Attorneys \- 361st-No Value-Adult Felony-No Value	103295	Rodri*****LLC
			800687	Shime*****
			801423	Davis*****
			92302	Tumb*****PLLC
			95315	Law O*****Maltsberger
			96520	Thoma*****
			97200	Barto*****
	01000-11010000-72207000-00000-1104-000000	General Fund-Court Support \- Criminal-Court Appointed Attorneys \- 361st-No Value-Adult Misdemeanor-No Value	103295	Rodri*****LLC
			801423	Davis*****
			92302	Tumb*****PLLC
			97200	Barto*****

Payment Date	Account	Account Description	Supplier Number	Party Name
6/23/2026	01000-11010000-72207000-00000-1104-000000	General Fund-Court Support \- Criminal-Court Appointed Attorneys \- 361st-No Value-Adult Misdemeanor-No Value	97200	Barto*****
	01000-11010000-72208000-00000-0000-000000	General Fund-Court Support \- Criminal-Court Appointed Attorneys \- Juvenile-No Value-No Value-No Value	102636	Gendr*****
	01000-11010000-72209000-00000-0000-000000	General Fund-Court Support \- Criminal-Court Appointed Interpreter-No Value-No Value-No Value	101573	Lone *****g LLC
			19957	Langu*****s
			91804	Sanch*****
			92425	Zaval*****
			95313	USA C*****eters
			96694	Hu, J*****
	01000-11010000-72660000-00000-0000-000000	General Fund-Court Support \- Criminal-Psychiatric Services-No Value-No Value-No Value	92512	Sam H*****iversity
	01000-11010000-72670000-00000-0000-000000	General Fund-Court Support \- Criminal-Psychological Services-No Value-No Value-No Value	96536	Cantu*****
	01000-11020000-61020000-00000-0000-000000	General Fund-Court Support \- Civil-Autopsy-No Value-No Value-No Value	90303	Hilli*****
	01000-11020000-71040000-00000-0000-000000	General Fund-Court Support \- Civil-Contract Placement \- Secure-No Value-No Value-No Value	103175	Youth*****estments LLC
			91405	Coll*****
			94771	Nuece*****
			96757	Rite *****
	01000-11020000-72660000-00000-0000-000000	General Fund-Court Support \- Civil-Psychiatric Services-No Value-No Value-No Value	102832	Buzza*****sulting PA
	01000-11024720-72110000-00000-1001-000000	General Fund-Court Support Child Protective Svc \- 472nd-Attorney Fees-No Value-Custodial Parents-No Value	102621	Law O*****Medina PLLC
	01000-11024720-72110000-00000-1002-000000	General Fund-Court Support Child	102621	Law O*****Medina PLLC

Payment Date	Account	Account Description	Supplier Number	Party Name
6/23/2026		Protective Svc \- 472nd-Attorney Fees-No Value-Non Custodial Parents-No Value		
	01000-11024720-72110000-00000-1005-000000	General Fund-Court Support Child Protective Svc \- 472nd-Attorney Fees-No Value-Children-No Value	102621	Law O*****Medina PLLC
	01000-11050000-72540000-00000-0000-000000	General Fund-Court Support \- Guardianship-Physician Services-No Value-No Value-No Value	102832 96087	Buzza*****sulting PA Rocke*****PhD PLLC
	01000-11050000-72660000-00000-0000-000000	General Fund-Court Support \- Guardianship-Psychiatric Services-No Value-No Value-No Value	102832	Buzza*****sulting PA
	01000-11100000-60170000-00000-0000-000000	General Fund-Fleet Shop \- Light Equipment \- Administration-Copier/Printer/Fax Supplies-No Value-No Value-No Value	94806	Perry
	01000-11100000-60500000-00000-0000-000000	General Fund-Fleet Shop \- Light Equipment \- Administration-Equipment & I.T. Enhancement-No Value-No Value-No Value	96813	MNJ T*****ct Inc
	01000-11100000-65540000-00000-0000-000000	General Fund-Fleet Shop \- Light Equipment \- Administration-Copier/Printer/Fax Maintenance-No Value-No Value-No Value	9038	Xerox*****ons Southwest
	01000-11100000-65720000-00000-0000-000000	General Fund-Fleet Shop \- Light Equipment \- Administration-Shop Supplies-No Value-No Value-No Value	101274 1639	AutoZ***** Bryan*****nc
	01000-11100000-65850000-00000-0000-000000	General Fund-Fleet Shop \- Light Equipment \- Administration-Tires-No Value-No Value-No Value	10804	The G*****ubber Company
	01000-11100000-65950000-00000-0000-000000	General Fund-Fleet Shop \- Light Equipment \- Administration-Vehicle Maintenance-No Value-No Value-No Value	10090 101274 102326 21268	Sterl***** AutoZ***** BDS T***** LP Brazo*****

Payment Date	Account	Account Description	Supplier Number	Party Name
6/23/2026	01000-11100000-65950000-00000-0000-000000	General Fund-Fleet Shop \- Light Equipment \- Administration-Vehicle Maintenance-No Value-No Value-No Value	21268	Brazo*****
			3354	O'Rei*****
			96665	Colle*****Lincoln LLC
			97256	Texas*****s
	01000-11100000-71512000-00000-0000-000000	General Fund-Fleet Shop \- Light Equipment \- Administration-Rental \- Uniforms-No Value-No Value-No Value	19837	Unifi*****
	01000-11200200-60020000-00000-0000-000000	General Fund-Collections \- Administration-Bank Service Charges-No Value-No Value-No Value	103564	EVO J*****
	01000-11200200-60400000-00000-0000-000000	General Fund-Collections \- Administration-Investigation Supplies-No Value-No Value-No Value	3187	West *****ration
	01000-11210020-60600000-00000-0000-000000	General Fund-Elections Administrator-	11714	Hart *****

Payment Date	Account	Account Description	Supplier Number	Party Name
6/23/2026		Office Supplies-No Value-No Value-No Value		
	01000-11210020-61500000-00000-0000-000000	General Fund-Elections Administrator-Printing-No Value-No Value-No Value	11714	Hart *****
	01000-11210020-65540000-00000-0000-000000	General Fund-Elections Administrator-Copier/Printer/Fax Maintenance-No Value-No Value-No Value	9038	Xerox*****ons Southwest
	01000-11210020-71502000-00000-0000-000000	General Fund-Elections Administrator-Rental \- Facility-No Value-No Value-No Value	101130	Wellb*****ch
	01000-12000100-65540000-00000-0000-000000	General Fund-County Treasurer \- Administration-Copier/Printer/Fax Maintenance-No Value-No Value-No Value	9038	Xerox*****ons Southwest
	01000-12000100-71020000-00000-0000-000000	General Fund-County Treasurer \- Administration-Computer Contracts-No Value-No Value-No Value	101349	ADP I*****
	01000-12500100-61680000-00000-0000-000000	General Fund-Risk Management \- Administration-Training-No Value-No Value-No Value	103110	HSI
	01000-12500100-65010000-00000-0000-000000	General Fund-Risk Management \- Administration-Accidents & Claims-No Value-No Value-No Value	6313	Texas*****Counties
			801553	City *****
			91345	CC Cr*****
	01000-13000100-60600000-00000-0000-000000	General Fund-Tax Assessor \- Collector \- Administration-Office Supplies-No Value-No Value-No Value	9728	Wilto*****Ltd
	01000-13000100-65540000-00000-0000-000000	General Fund-Tax Assessor \- Collector \- Administration-Copier/Printer/Fax Maintenance-No Value-No Value-No Value	9038	Xerox*****ons Southwest
	01000-15000100-61295000-00000-0000-000000	General Fund-Human Resources \- Administration-Employment Investigations-No Value-No Value-No Value	102239	Imper*****n Group Inc
	01000-15000100-65540000-00000-0000-000000	General Fund-Human Resources \- Administration-Copier/Printer/Fax Maintenance-No Value-No Value-No Value	9038	Xerox*****ons Southwest
	01000-16000100-71025000-00000-0000-000000	General Fund-County Auditor \- Administration-Contract Services-No Value-No Value-No Value	101724	The G*****
	01000-16500100-65540000-00000-0000-000000	General Fund-Purchasing \- Administration-Copier/Printer/Fax Maintenance-No Value-No Value-No Value	9038	Xerox*****ons Southwest
	01000-16500100-71701000-00000-0000-000000	General Fund-Purchasing \- Administration-Solid Waste \- Hauling-No Value-No Value-No Value	95577	Brazo*****aste Management Ag

Payment Date	Account	Account Description	Supplier Number	Party Name
6/23/2026	01000-17000006-72590000-00000-0000-000000	General Fund-Facility Services \- Non Capital-Professional Fees \- Other-No Value-No Value-No Value	102961	Tom G***** Engineers Inc
	01000-17000100-60440000-00000-0000-000000	General Fund-Facilities Services \- Administration-Janitorial Supplies-No Value-No Value-No Value	91161	Prost*****
	01000-17000100-60500000-00000-0000-000000	General Fund-Facilities Services \- Administration-Equipment & I.T. Enhancement-No Value-No Value-No Value	97596	Amazo*****
	01000-17000100-65050000-00000-0000-000000	General Fund-Facilities Services \- Administration-Building Maintenance-No Value-No Value-No Value	11869	Lowes*****
			21638	HD Su*****Maintenance
			93186	Batte*****
			93424	ULINE*****
			97525	AED B*****
			97596	Amazo*****
	01000-17000100-65051000-00000-0000-000000	General Fund-Facilities Services \- Administration-Air Conditioning/Heating Maintenance-No Value-No Value-No Value	100728	Texas*****
			11807	Grain*****
			21688	Carri*****C
			7141	Baker*****mpany LLC
			97431	Johns*****llege Station
			97596	Amazo*****
	01000-17000100-65052000-00000-0000-000000	General Fund-Facilities Services \- Administration-Carpentry & Building Repair-No Value-No Value-No Value	11869	Lowes*****

Payment Date	Account	Account Description	Supplier Number	Party Name
6/23/2026	01000-17000100-65053000-00000-0000-000000	General Fund-Facilities Services \- Administration-Electrical System Maintenance-No Value-No Value-No Value	11869	Lowes*****
			262	Deale*****pply
			94838	City *****Company
			97596	Amazo*****
	01000-17000100-65055000-00000-0000-000000	General Fund-Facilities Services \- Administration-Surveillance & Security Maintenance-No Value-No Value-No Value	9794	CDW G*****
	01000-17000100-65056000-00000-0000-000000	General Fund-Facilities Services \- Administration-Plumbing Maintenance-No Value-No Value-No Value	11869	Lowes*****
			494	Valle*****upply Co Inc
			90312	State*****ons
			92196	Fergu*****LLC
			93501	Marks*****
	01000-17000100-65660000-00000-0000-000000	General Fund-Facilities Services \- Administration-Road and Bridge \- Field Supplies-No Value-No Value-No Value	97596	Amazo*****
	01000-17000100-71206000-00000-0000-000000	General Fund-Facilities Services \- Administration-Maintenance-No Value-No Value-No Value	5645	Texas*****icensing & Regulation
	01000-17000100-71206700-00000-0000-000000	General Fund-Facilities Services \- Administration-HVAC Control Contract-No Value-No Value-No Value	103801	Indus*****tment
	01000-17000100-71500000-00000-0000-000000	General Fund-Facilities Services \- Administration-Rental \- Equipment-No Value-No Value-No Value	10153	Musta*****es
	01000-17000100-71512000-00000-0000-000000	General Fund-Facilities Services \- Administration-Rental \- Uniforms-No Value-No Value-No Value	19837	Unifi*****
01000-18000100-60400000-00000-0000-000000	General Fund-County Attorney \- Administration-Investigation Supplies-No Value-No Value-No Value	429	CHI S*****I Health Ctr	
01000-18000100-61280000-00000-0000-000000	General Fund-County Attorney \- Administration-Dues-No Value-No Value-No Value	Employee	John *****	
			Rebec*****	
01000-18000100-61620000-00000-0000-000000	General Fund-County Attorney \- Administration-Subscriptions & Publications-No Value-No Value-No Value	16290	Lexis*****	
01000-18000100-65540000-00000-0000-000000	General Fund-County Attorney \-	9038	Xerox*****ons Southwest	

Payment Date	Account	Account Description	Supplier Number	Party Name
6/23/2026		Administration-Copier/Printer/Fax Maintenance-No Value-No Value-No Value		
	01000-18000100-71025000-00000-0000-000000	General Fund-County Attorney \- Administration-Contract Services-No Value-No Value-No Value	97068	Iron *****
	01000-19000100-60500000-00000-0000-000000	General Fund-District Attorney \- Administration-Equipment & I.T. Enhancement-No Value-No Value-No Value	11497	South*****house
	01000-19000100-61110000-00000-0000-000000	General Fund-District Attorney \- Administration-Conference & Seminar Fees-No Value-No Value-No Value	3745	Texas*****ty Attorneys Associat
	01000-19000100-61210000-00000-0000-000000	General Fund-District Attorney \- Administration-Court Costs-No Value-No Value-No Value	103674	Words*****
			93937	Kirby*****
			Employee	Kevin*****
	01000-19000100-61620000-00000-0000-000000	General Fund-District Attorney \- Administration-Subscriptions & Publications-No Value-No Value-No Value	3187	West *****ration
			96474	Trans*****ernative Data Solution
	01000-19000100-61801000-00000-0000-000000	General Fund-District Attorney \- Administration-Travel-No Value-No Value-No Value	Employee	Caleb*****
				Jenni*****en
	01000-19000100-61970000-00000-0000-000000	General Fund-District Attorney \- Administration-Witness Reimbursement-No Value-No Value-No Value	103435	Winga*****
	01000-19000100-65540000-00000-0000-000000	General Fund-District Attorney \- Administration-Copier/Printer/Fax Maintenance-No Value-No Value-No Value	9038	Xerox*****ons Southwest
	01000-20000100-65540000-00000-0000-000000	General Fund-District Clerk \- Administration-Copier/Printer/Fax Maintenance-No Value-No Value-No Value	9038	Xerox*****ons Southwest
	01000-20010000-65540000-00000-0000-000000	General Fund-District Clerk \- Jury Services-Copier/Printer/Fax Maintenance-No Value-No Value-No Value	9038	Xerox*****ons Southwest
	01000-21000100-65540000-00000-0000-000000	General Fund-County Clerk \- Administration-Copier/Printer/Fax Maintenance-No Value-No Value-No Value	9038	Xerox*****ons Southwest
	01000-22000100-60170000-00000-0000-000000	General Fund-85th District Court \- Administration-Copier/Printer/Fax Supplies-No Value-No Value-No Value	94806	Perry
	01000-22000100-60600000-00000-0000-000000	General Fund-85th District Court \- Administration-Office Supplies-No Value-No Value-No Value	94806	Perry
	01000-22000100-61415000-00000-0000-000000	General Fund-85th District Court \- Administration-Jurors \- Petit Jury-No	94806	Perry
			95512	Longh*****house Inc

Payment Date	Account	Account Description	Supplier Number	Party Name
6/23/2026	01000-22000100-61415000-00000-0000-000000	General Fund-85th District Court \- Administration-Jurors \- Petit Jury-No Value-No Value-No Value		
	01000-22000100-61620000-00000-0000-000000	General Fund-85th District Court \- Administration-Subscriptions & Publications-No Value-No Value-No Value	3187	West*****ration
	01000-22100100-65540000-00000-0000-000000	General Fund-272nd District Court \- Administration-Copier/Printer/Fax Maintenance-No Value-No Value-No Value	9038	Xerox*****ons Southwest
	01000-22200100-60500000-00000-0000-000000	General Fund-361st District Court \- Administration-Equipment & I.T. Enhancement-No Value-No Value-No Value	11497	South*****ehouse
	01000-22300100-60500000-00000-0000-000000	General Fund-472nd District Court \- Administration-Equipment & I.T. Enhancement-No Value-No Value-No Value	9794	CDW G*****
	01000-22300100-61110000-00000-0000-000000	General Fund-472nd District Court \- Administration-Conference & Seminar Fees-No Value-No Value-No Value	8028	Texas***** Association
	01000-22300100-61900000-00000-0000-000000	General Fund-472nd District Court \- Administration-Visiting Court Reporters-No Value-No Value-No Value	103572	Shiel*****
	01000-22600100-61110000-00000-0000-000000	General Fund-Misdemeanor Associate Court \- Administration-Conference & Seminar Fees-No Value-No Value-No Value	92512	Sam H*****iversity
	01000-22600100-65540000-00000-0000-000000	General Fund-Misdemeanor Associate Court \- Administration-Copier/Printer/Fax Maintenance-No Value-No Value-No Value	9038	Xerox*****ons Southwest
	01000-23000100-60170000-00000-0000-000000	General Fund-County Court at Law #1 \- Administration-Copier/Printer/Fax Supplies-No Value-No Value-No Value	94806	Perry
	01000-23000100-61280000-00000-0000-000000	General Fund-County Court at Law #1 \- Administration-Dues-No Value-No Value-No Value	Employee	Amand*****e
	01000-23000100-65540000-00000-0000-000000	General Fund-County Court at Law #1 \- Administration-Copier/Printer/Fax Maintenance-No Value-No Value-No Value	9038	Xerox*****ons Southwest
	01000-24101100-60020000-00000-0000-000000	General Fund-Justice of Peace \- Precinct 1 \- Administration-Bank Service Charges-No Value-No Value-No Value	103564	EVO I*****
	01000-24101100-61110000-00000-0000-000000	General Fund-Justice of Peace \- Precinct 1 \- Administration-Conference & Seminar Fees-No Value-No Value-No Value	Employee	Amber***** Janet*****
	01000-24201100-61801000-00000-0000-000000	General Fund-Justice of Peace \-	Employee	Terre*****

Payment Date	Account	Account Description	Supplier Number	Party Name
6/23/2026		Precinct 2 \- Administration-Travel-No Value-No Value-No Value		
	01000-24301100-60170000-00000-0000-000000	General Fund-Justice of Peace \- Precinct 3 \- Administration-Copier/Printer/Fax Supplies-No Value-No Value-No Value	9728	Wilton*****Ltd
	01000-24301100-61060000-00000-0000-000000	General Fund-Justice of Peace \- Precinct 3 \- Administration-Bonds-No Value-No Value-No Value	8494	Old R*****roup
	01000-28000100-60080000-00000-0000-000000	General Fund-Sheriff Office \- Administration-Clothing/Uniforms-No Value-No Value-No Value	103342	Webbs*****
	01000-28000100-60320000-00000-0000-000000	General Fund-Sheriff Office \- Administration-Firearms Readiness-No Value-No Value-No Value	3486	GT Di*****
	01000-28000100-60400000-00000-0000-000000	General Fund-Sheriff Office \- Administration-Investigation Supplies-No Value-No Value-No Value	11869	Lowe*****
			97596	Amazo*****
	01000-28000100-60600000-00000-0000-000000	General Fund-Sheriff Office \- Administration-Office Supplies-No Value-No Value-No Value	11869	Lowe*****
	01000-28000100-61060000-00000-0000-000000	General Fund-Sheriff Office \- Administration-Bonds-No Value-No Value-No Value	90208	CNA S*****
	01000-28000100-61110000-00000-0000-000000	General Fund-Sheriff Office \- Administration-Conference & Seminar Fees-No Value-No Value-No Value	Employee	Krist*****
	01000-28000100-61500000-00000-0000-000000	General Fund-Sheriff Office \- Administration-Printing-No Value-No Value-No Value	93571	BCS P*****aphics
	01000-28000100-61801000-00000-0000-000000	General Fund-Sheriff Office \- Administration-Travel-No Value-No Value-No Value	Employee	Kevin*****
	01000-28000100-65050000-00000-0000-000000	General Fund-Sheriff Office \- Administration-Building Maintenance-No Value-No Value-No Value	97596	Amazo*****
	01000-28000100-65350000-00000-0000-000000	General Fund-Sheriff Office \- Administration-Gasoline Expenditure-No Value-No Value-No Value	7176	Colle*****
	01000-28000100-65540000-00000-0000-000000	General Fund-Sheriff Office \- Administration-Copier/Printer/Fax Maintenance-No Value-No Value-No Value	9038	Xerox*****ons Southwest
	01000-28000100-71020000-00000-0000-000000	General Fund-Sheriff Office \- Administration-Computer Contracts-No Value-No Value-No Value	3187	West *****ration
	01000-28000100-71502000-00000-0000-000000	General Fund-Sheriff Office \- Administration-Rental \- Facility-No	10336	Texas***** Extension Service

Payment Date	Account	Account Description	Supplier Number	Party Name
6/23/2026		Value-No Value-No Value		
	01000-28002000-60080000-00000-0000-000000	General Fund-Sheriff Office \- Jail Administration-Clothing/Uniforms-No Value-No Value-No Value	103342	Webbs*****
			Employee	Twist*****ton
	01000-28002000-60350000-00000-0000-000000	General Fund-Sheriff Office \- Jail Administration-Food and Food Supplements-No Value-No Value-No Value	101661	Labat*****Supply Company
			101854	Hilan*****mpany LLC
			103673	FBS o*****
			10500	US Fo*****
			6151	Perfo*****ce Temple
			96384	Best *****p
			96957	Sysco*****
	01000-28002000-60440000-00000-0000-000000	General Fund-Sheriff Office \- Jail Administration-Janitorial Supplies-No Value-No Value-No Value	91161	Prost*****
	01000-28002000-60600000-00000-0000-000000	General Fund-Sheriff Office \- Jail Administration-Office Supplies-No Value-No Value-No Value	91018	Stapl*****mmercial Inc
	01000-28002000-61280000-00000-0000-000000	General Fund-Sheriff Office \- Jail Administration-Dues-No Value-No Value-No Value	92512	Sam H*****iversity
	01000-28002000-61801000-00000-0000-000000	General Fund-Sheriff Office \- Jail Administration-Travel-No Value-No Value-No Value	Employee	Kevin***** Willi*****
	01000-28002000-61806000-00000-0000-000000	General Fund-Sheriff Office \- Jail Administration-Travel \- Inmate Transport-No Value-No Value-No Value	101828	Oklah*****hority
01000-28002000-65050000-00000-0000-000000	General Fund-Sheriff Office \- Jail Administration-Building Maintenance-No Value-No Value-No Value	97596	Amazo*****	
01000-28002000-65320000-00000-0000-000000	General Fund-Sheriff Office \- Jail Administration-Equipment Maintenance-No Value-No Value-No Value	93681	Ikes *****C	

Payment Date	Account	Account Description	Supplier Number	Party Name
6/23/2026	01000-28002000-65540000-00000-0000-000000	General Fund-Sheriff Office \- Jail Administration-Copier/Printer/Fax Maintenance-No Value-No Value-No Value	9038	Xerox*****ons Southwest
	01000-28002000-71020000-00000-0000-000000	General Fund-Sheriff Office \- Jail Administration-Computer Contracts-No Value-No Value-No Value	100604	Lexip*****igital
	01000-28002000-71500000-00000-0000-000000	General Fund-Sheriff Office \- Jail Administration-Rental \- Equipment-No Value-No Value-No Value	1289	Texas*****e
	01000-28002000-71701000-00000-0000-000000	General Fund-Sheriff Office \- Jail Administration-Solid Waste \- Hauling-No Value-No Value-No Value	95577	Brazo*****aste Management Ag
	01000-28002000-72157000-00000-0000-000000	General Fund-Sheriff Office \- Jail Administration-Counseling Services-No Value-No Value-No Value	801917	Luepn*****
	01000-28002006-65052000-00000-0000-000000	General Fund-Sheriff Office \- Jail \- Non Capital-Carpentry & Building Repair-No Value-No Value-No Value	96328	REC I*****
	01000-29002800-72270000-00000-0000-000000	General Fund-Jail Correctional Medicine \- Administration-Dental Services-No Value-No Value-No Value	92883	Dentr***** PC Inc
	01000-29002800-72590000-00000-0000-000000	General Fund-Jail Correctional Medicine \- Administration-Professional Fees \- Other-No Value-No Value-No Value	103114	Acro *****
	01000-29003100-61470000-00000-0000-000000	General Fund-Juvenile Correctional Medicine \- Administration- Prescriptions-No Value-No Value-No Value	102148	Polar*****ices of Warrington LL
	01000-30101100-65350000-00000-0000-000000	General Fund-Constable Precinct 1 \- Administration-Gasoline Expenditure-No Value-No Value-No Value	7176	Colle*****
	01000-30101100-65540000-00000-0000-000000	General Fund-Constable Precinct 1 \- Administration-Copier/Printer/Fax Maintenance-No Value-No Value-No Value	9038	Xerox*****ons Southwest
	01000-30201100-60600000-00000-0000-000000	General Fund-Constable Precinct 2 \-	94806	Perry

Payment Date	Account	Account Description	Supplier Number	Party Name
6/23/2026	01000-30201100-60600000-00000-0000-000000	General Fund-Constable Precinct 2 \- Administration-Office Supplies-No Value-No Value-No Value	94806	Perry
	01000-30201100-61620000-00000-0000-000000	General Fund-Constable Precinct 2 \- Administration-Subscriptions & Publications-No Value-No Value-No Value	3187	West *****ration
	01000-30301100-60080000-00000-0000-000000	General Fund-Constable Precinct 3 \- Administration-Clothing/Uniforms-No Value-No Value-No Value	97555	EDT T*****
	01000-30301100-65350000-00000-0000-000000	General Fund-Constable Precinct 3 \- Administration-Gasoline Expenditure-No Value-No Value-No Value	7176	Colle*****
	01000-30401100-60600000-00000-0000-000000	General Fund-Constable Precinct 4 \- Administration-Office Supplies-No Value-No Value-No Value	9728	Wilto*****Ltd
	01000-31000100-61465000-00000-0000-000000	General Fund-Juvenile Services \- Administration Probation-Polygraph Tests-No Value-No Value-No Value	103438	Russ,*****k
	01000-31000100-61470000-00000-0000-000000	General Fund-Juvenile Services \- Administration Probation-Prescriptions-No Value-No Value-No Value	94771	Nuece*****
	01000-31000100-65540000-00000-0000-000000	General Fund-Juvenile Services \- Administration Probation-Copier/Printer/Fax Maintenance-No Value-No Value-No Value	9038	Xerox*****ons Southwest
	01000-31000100-71500000-00000-0000-000000	General Fund-Juvenile Services \- Administration Probation-Rental \- Equipment-No Value-No Value-No Value	91872	Falls*****
	01000-31000100-72540000-00000-0000-000000	General Fund-Juvenile Services \- Administration Probation-Physician Services-No Value-No Value-No Value	94771	Nuece*****
	01000-31000100-72660000-00000-0000-000000	General Fund-Juvenile Services \- Administration Probation-Psychiatric Services-No Value-No Value-No Value	94771 96757	Nuece***** Rite *****
	01000-31000140-61530000-00000-0000-000000	General Fund-Juvenile Services \- Administration Community Based Mental Health-Psychological Test Supply-No Value-No Value-No Value	21468	Sassi*****
	01000-31000220-60240000-00000-0000-000000	General Fund-Juvenile Services \- Detention-Detention Supplies-No Value-No Value-No Value	94806	Perry
	01000-31000220-60350000-00000-0000-000000	General Fund-Juvenile Services \- Detention-Food and Food Supplements-No Value-No Value-No Value	101854 102244 96917	Hilan*****mpany LLC Broth***** Gordo*****nc
	01000-31000220-60440000-00000-0000-000000	General Fund-Juvenile Services \- Detention-Janitorial Supplies-No Value-No Value-No Value	94806	Perry

Payment Date	Account	Account Description	Supplier Number	Party Name
6/23/2026	01000-31000220-61060000-00000-0000-000000	General Fund-Juvenile Services \- Detention-Bonds-No Value-No Value-No Value	103396	HUB I*****
	01000-31000220-61680000-00000-0000-000000	General Fund-Juvenile Services \- Detention-Training-No Value-No Value-No Value	Employee	Selwy*****
	01000-31000220-65540000-00000-0000-000000	General Fund-Juvenile Services \- Detention-Copier/Printer/Fax Maintenance-No Value-No Value-No Value	9038	Xerox*****ons Southwest
	01000-31000220-72590000-00000-0000-000000	General Fund-Juvenile Services \- Detention-Professional Fees \- Other-No Value-No Value-No Value	97574	Schoo*****urce Group Inc
	01000-31000330-65540000-00000-0000-000000	General Fund-Academy \- Community Based-Copier/Printer/Fax Maintenance-No Value-No Value-No Value	9038	Xerox*****ons Southwest
	01000-34000100-61470900-00000-0000-000000	General Fund-Indigent Health Care \- Administration-Prescriptions \- Jail-No Value-No Value-No Value	102148	Polar*****ices of Warrington LL
	01000-34000100-72382000-00000-0000-000000	General Fund-Indigent Health Care \- Administration-Outpatient Services-No Value-No Value-No Value	429	CHI S*****I Health Ctr
	01000-34000100-72382900-00000-0000-000000	General Fund-Indigent Health Care \- Administration-Outpatient Services \- Jail-No Value-No Value-No Value	19277	City *****
			429	CHI S*****I Health Ctr
			97593	Scott*****I Hospital
	01000-34000100-72440000-00000-0000-000000	General Fund-Indigent Health Care \- Administration-Lab & Xl-Ray-No Value-No Value-No Value	1369	Brazo*****ty Action Agency
			21421	Labor*****n of America
			94789	Texas*****
			97291	Privi*****Gulf Coast PLLC
			97593	Scott*****I Hospital
	01000-34000100-72440900-00000-0000-000000	General Fund-Indigent Health Care \- Administration-Lab & Xl-Ray \- Jail-No Value-No Value-No Value	103511	Symet*****xas
			12347	Scy j*****
			211	Bryan*****iates
			21421	Labor*****n of America
			429	CHI S*****I Health Ctr
			97593	Scott*****I Hospital
	01000-34000100-72540000-00000-0000-000000	General Fund-Indigent Health Care \- Administration-Physician Services-No Value-No Value-No Value	102452	Centu*****rtners Inc
			1369	Brazo*****ty Action Agency
			800692	Linds*****
			90267	Brazo*****re
			94789	Texas*****
			97593	Scott*****I Hospital
	01000-34000100-72540900-00000-0000-000000	General Fund-Indigent Health Care \- Administration-Physician Services \- Jail-No Value-No Value-No Value	102452	Centu*****rtners Inc
			103511	Symet*****xas
			103704	Hunts*****Hospital
			211	Bryan*****iates

Payment Date	Account	Account Description	Supplier Number	Party Name
6/23/2026	01000-34000100-72540900-00000-0000-000000	General Fund-Indigent Health Care \- Administration-Physician Services \- Jail-No Value-No Value-No Value	429	CHI S***** Health Ctr
			61804	Bryan*****cians
			97593	Scott***** Hospital
	01000-34200100-61500000-00000-0000-000000	General Fund-Forensic Services \- Administration-Printing-No Value-No Value	1229	Alpha*****
	01000-35500100-71506000-00000-0000-000000	General Fund-Emergency Management \- Administration-Rental \- Office Space-No Value-No Value-No Value	19277	City *****
	01000-36000006-65050000-00000-0000-000000	General Fund-Exposition Center \- Non Capital-Building Maintenance-No Value-No Value-No Value	103182	SpawG*****n Corporation
	01000-36000100-60315000-00000-0000-000000	General Fund-Exposition Center \- Administration-Event Supplies/Services-No Value-No Value-No Value	93424	ULINE*****
			97545	Queen*****f Texas
	01000-36000100-60440000-00000-0000-000000	General Fund-Exposition Center \- Administration-Janitorial Supplies-No Value-No Value-No Value	94806	Perry
	01000-36000100-65320000-00000-0000-000000	General Fund-Exposition Center \- Administration-Equipment Maintenance-No Value-No Value-No Value	90525	Brazo***** Supply Inc
	01000-36000100-65540000-00000-0000-000000	General Fund-Exposition Center \- Administration-Copier/Printer/Fax Maintenance-No Value-No Value-No Value	9038	Xerox*****ons Southwest
	01000-36000100-71206600-00000-0000-000000	General Fund-Exposition Center \- Administration-Grease Trap Services-No Value-No Value-No Value	96339	G & L*****ices LLC
	01000-36000100-71701000-00000-0000-000000	General Fund-Exposition Center \- Administration-Solid Waste \- Hauling-No Value-No Value-No Value	95577	Brazo*****aste Management Ag
	01000-36500100-65540000-00000-0000-000000	General Fund-Brazos Center \- Administration-Copier/Printer/Fax Maintenance-No Value-No Value-No Value	9038	Xerox*****ons Southwest
	01000-37000100-60170000-00000-0000-000000	General Fund-County Agriculture Extension \- Administration-Copier/Printer/Fax Supplies-No Value-No Value-No Value	9728	Wilto*****Ltd
01000-37000100-60600000-00000-0000-000000	General Fund-County Agriculture Extension \- Administration-Office Supplies-No Value-No Value-No Value	9728	Wilto*****Ltd	
01000-37000100-61110000-00000-0000-000000	General Fund-County Agriculture Extension \- Administration-Conference & Seminar Fees-No Value-No Value-No Value	Employee	Flora*****	
01000-37000100-61801000-00000-0000-000000	General Fund-County Agriculture	Employee	Ashle*****	

Payment Date	Account	Account Description	Supplier Number	Party Name
6/23/2026	01000-37000100-61801000-00000-0000-000000	General Fund-County Agriculture Extension \- Administration-Travel-No Value-No Value-No Value	Employee	Chadd*****ton Emily***** Flora***** Rober*****
	01000-37000100-65540000-00000-0000-000000	General Fund-County Agriculture Extension \- Administration-Copier/Printer/Fax Maintenance-No Value-No Value-No Value	9038	Xerox*****ons Southwest
	01000-38000100-60080000-00000-0000-000000	General Fund-Child Protective Services \- Administration-Clothing/Uniforms-No Value-No Value-No Value	103237	Larso*****
			103697	Reese*****
			103818	Yzagu*****
			103823	Rios,*****
			16490	Wal-M*****c
	01000-38000100-61320006-00000-0000-000000	General Fund-Child Protective Services \- Administration-Foster Care \- Summer Camp-No Value-No Value-No Value	103820	Faith*****y Learning Center
	01000-56001000-60600000-00000-0000-000000	General Fund-Road & Bridge \- Administration-Office Supplies-No Value-No Value-No Value	9728	Wilto*****Ltd
	01000-56001000-61680000-00000-0000-000000	General Fund-Road & Bridge \- Administration-Training-No Value-No Value-No Value	103210	Unive*****t Arlington
			10336	Texas***** Extension Service
			90052	Texas*****ransportation
	01000-56001000-65540000-00000-0000-000000	General Fund-Road & Bridge \- Administration-Copier/Printer/Fax Maintenance-No Value-No Value-No Value	9038	Xerox*****ons Southwest
	01000-56001000-65660000-00000-0000-000000	General Fund-Road & Bridge \- Administration-Road and Bridge \- Field Supplies-No Value-No Value-No Value	97596	Amazo*****
	01000-56001000-65670000-00000-0000-000000	General Fund-Road & Bridge \- Administration-Road and Bridge \- Maintenance\-General-No Value-No Value-No Value	100554	BWI C*****
			101554	Dudle*****C
			101907	Clark***** Texas Inc
			102380	BPI M*****
			96212	Shur-*****c
01000-56001000-65690000-00000-0000-000000	General Fund-Road & Bridge \- Administration-Bridge Maintenance-No	101554	Dudle*****C	

Payment Date	Account	Account Description	Supplier Number	Party Name
6/23/2026	01000-56001000-65690000-00000-0000-000000	General Fund-Road & Bridge \- Administration-Bridge Maintenance-No Value-No Value-No Value	101554	Dudle*****C
			101555	Goodw*****
			102695	Solid*****tion
	01000-56001000-65700000-00000-0000-000000	General Fund-Road & Bridge \- Administration-Road Signs-No Value-No Value-No Value	8236	Vulca*****
			97311	Kimba*****
	01000-56001000-71500000-00000-0000-000000	General Fund-Road & Bridge \- Administration-Rental \- Equipment-No Value-No Value-No Value	102308	Madol*****al & Sales Inc
	01000-56001000-71512000-00000-0000-000000	General Fund-Road & Bridge \- Administration-Rental \- Uniforms-No Value-No Value-No Value	19837	Unifi*****
	01000-56001000-72320000-00000-0000-000000	General Fund-Road & Bridge \- Administration-Engineering Consulting-No Value-No Value-No Value	101555	Goodw*****
	01000-56001000-72590000-00000-0000-000000	General Fund-Road & Bridge \- Administration-Professional Fees \- Other-No Value-No Value-No Value	100242	Innov*****tion Solutions Inc
01000-56001000-80715000-00000-0000-000000	General Fund-Road & Bridge \- Administration-Roads \- Capital-No Value-No Value-No Value	101554	Dudle*****C	
		101555	Goodw*****	
01000-56002000-65320000-00000-0000-000000	General Fund-Fleet Shop \- Heavy Equipment-Equipment Maintenance-No Value-No Value-No Value	15561	Capit*****ce of Austin Inc	
		21268	Brazo*****	
		73	Musta*****	

Payment Date	Account	Account Description	Supplier Number	Party Name
6/23/2026	01000-56002000-65320000-00000-0000-000000	General Fund-Fleet Shop \- Heavy Equipment-Equipment Maintenance-No Value-No Value-No Value	90180	Perfo*****
			93681	Ikes *****C
			95666	KMC F*****
			96270	Asco *****
	01000-56002000-65720000-00000-0000-000000	General Fund-Fleet Shop \- Heavy Equipment-Shop Supplies-No Value-No Value-No Value	97311	Kimba*****
	01000-56002000-65850000-00000-0000-000000	General Fund-Fleet Shop \- Heavy Equipment-Tires-No Value-No Value-No Value	102976	Travi***** LLC
	01000-56002000-71512000-00000-0000-000000	General Fund-Fleet Shop \- Heavy Equipment-Rental \- Uniforms-No Value-No Value-No Value	19837	Unifi*****
	01000-56005000-71025000-00000-0000-000000	General Fund-Environmental Protection-Contract Services-No Value-No Value-No Value	807314	Junct*****Inc
	01000-56005000-71500000-00000-0000-000000	General Fund-Environmental Protection-Rental \- Equipment-No Value-No Value-No Value	102308	Madol*****al & Sales Inc
	01000-56005000-71701000-00000-0000-000000	General Fund-Environmental Protection-Solid Waste \- Hauling-No Value-No Value-No Value	1289	Texas*****e
95577			Brazo*****aste Management Ag	
	11000-11002500-73751000-00000-0000-000000	Hotel Occupancy Tax Fund-Hotel Occupancy Tax-Texas A&M Agrilife Extension Service-No Value-No Value-No Value	96898	Texas*****tension Service
	11000-11002900-72030000-00000-0000-000000	Hotel Occupancy Tax Fund-Expo Complex Improvements-Architectural Services-No Value-No Value-No Value	101555	Goodw*****
	11000-11002900-72590000-00000-0000-000000	Hotel Occupancy Tax Fund-Expo Complex Improvements-Professional Fees \- Other-No Value-No Value-No Value	101554	Dudle*****C
102961			Tom G***** Engineers Inc	
	13000-00000000-30999000-00000-0000-000000	Unclaimed Property Fund-No Value-Unclaimed Funds-No Value-No Value-No Value	7066	Texas*****Public Accts
	15000-52000100-61620000-00000-0000-000000	Law Library Fund-Law Library Fund \- Administration-Subscriptions & Publications-No Value-No Value-No Value	16290	Lexis*****
	18000-30021100-61680000-00000-0000-000000	Law Enforcement Education Fund-LEOSE \- Constable Pct 2-Training-No Value-No Value-No Value	21410	Texas*****y
	27000-12006000-60170000-00000-0000-000000	Bail Bond Board Fund-Bail Bond Board Fund-Copier/Printer/Fax Supplies-No Value-No Value-No Value	94806	Perry
	29000-13006000-61801000-00000-0000-000000	Vehicle Inventory Interest Fund-Vehicle Inventory Interest-Travel-No Value-No Value-No Value	Employee	Angel*****
				Melis*****
	30000-227100-71025000-00000-0000-000000	Brazos County Grant Fund-Specialty	96167	Recov*****olutions LLC

Payment Date	Account	Account Description	Supplier Number	Party Name
6/23/2026		Court \- Adult Drug-Contract Services-No Value-No Value-No Value		
	30000-227200-71025000-00000-0000-000000	Brazos County Grant Fund-Specialty Court \- Mental Health-Contract Services-No Value-No Value-No Value	96167	Recov*****olutions LLC
	30000-272300-61210000-00000-0000-000000	Brazos County Grant Fund-Texas Indigent Defense Commission Grant\--212\--25\--C03-Court Costs-No Value-No Value-No Value	96087	Rocke*****PhD PLLC
	30000-272300-61280000-00000-0000-000000	Brazos County Grant Fund-Texas Indigent Defense Commission Grant\--212\--25\--C03-Dues-No Value-No Value-No Value	Employee	Robbi***** McClung
	30000-272300-61401000-00000-0000-000000	Brazos County Grant Fund-Texas Indigent Defense Commission Grant\--212\--25\--C03-Interpreters-No Value-No Value-No Value	95313	USA C*****eters
			96694	Hu, J*****
	30000-272300-61620000-00000-0000-000000	Brazos County Grant Fund-Texas Indigent Defense Commission Grant\--212\--25\--C03-Subscriptions & Publications-No Value-No Value-No Value	16290	Lexis*****
	30000-272300-61801000-00000-0000-000000	Brazos County Grant Fund-Texas Indigent Defense Commission Grant\--212\--25\--C03-Travel-No Value-No Value-No Value	Employee	Natal*****el
	30000-272400-61210000-00000-0000-000000	Brazos County Grant Fund-T.I.D.C. \- Public Defender Juvenile & Appellate Expansion 212\--26\--C14-Court Costs-No Value-No Value-No Value	103053	DeLaR*****
	30000-272400-61801000-00000-0000-000000	Brazos County Grant Fund-T.I.D.C. \- Public Defender Juvenile & Appellate Expansion 212\--26\--C14-Travel-No Value-No Value-No Value	Employee	Steph*****y
	30000-424100-65540000-00000-0000-000000	Brazos County Grant Fund-Metropolitan Planning \- Administration-Copier/Printer/Fax Maintenance-No Value-No Value-No Value	9038	Xerox*****ons Southwest
	30000-424100-71119000-00000-0000-000000	Brazos County Grant Fund-Metropolitan Planning \- Administration-Janitorial Services-No Value-No Value-No Value	102594	H&R C*****
	30000-424100-72320000-00000-0000-000000	Brazos County Grant Fund-Metropolitan Planning \- Administration-Engineering Consulting-No Value-No Value-No Value	102435	Kirle*****iates Inc
	30000-424100-72320000-00000-4242-000000	Brazos County Grant Fund-Metropolitan Planning \- Administration-Engineering Consulting-No Value-MPO \- Complete Streets Plan-No Value	102435	Kirle*****iates Inc
	31000-63340510-80100000-00000-0000-000000	American Rescue Plan Act-Medical Examiner \- Non Grant Capital-	102373	Broad*****

Payment Date	Account	Account Description	Supplier Number	Party Name
6/23/2026	31000-63340510-80100000-00000-0000-000000	American Rescue Plan Act-Medical Examiner \- Non Grant Capital-Buildings-No Value-No Value-No Value	102961	Tom G***** Engineers Inc
	32000-281002-80890000-00000-0000-000000	SB 22 2023 Rural Law Enforcement Salary Assistance Program-Sheriff's Office - Rural Law Enforcement Grant Program-Vehicles-No Value-No Value-No Value	21268	Brazo*****
	34000-19200100-60350000-00000-0000-000000	District Attorney Crime Fund-District Attorney Crime Fund \- Administration-Food and Food Supplements-No Value-No Value-No Value	97440	Rosa*****a Factory Ltd
	35000-21120000-71502000-00000-0000-000000	Election Contracts Fund-Primary Election Services-Rental \- Facility-No Value-No Value-No Value	96721	Galil*****ptist Church
	43230-63432306-71025000-00000-0000-000000	On System road Bond \- TXDOT-Leonard Road-Contract Services-No Value-No Value-No Value	102445	RG Mi*****nc
	43231-63432356-80715000-00000-0000-000000	Off System Road Bond-Road & Bridge-Roads \- Capital-No Value-No Value-No Value	101554	Dudle*****C
			101555	Goodw*****
			96264	Brazo*****
	43232-63432322-80100000-00000-0000-000000	2023-Certificates of Obligation-101 North-Buildings-No Value-No Value-No Value	101953	Plan *****ral Co
			102961	Tom G***** Engineers Inc
	45000-00000000-30302000-00000-0000-000000	Capital Improvement Fund-No Value-Contract Pay \- Retainages-No Value-No Value-No Value	102695	Solid*****tion
			103182	SpawG*****n Corporation
			96264	Brazo*****
			96328	REC I*****
	45000-63111000-80890000-00000-0000-000000	Capital Improvement Fund-Fleet Shop\Light Equipment\Capital-Vehicles-No Value-No Value-No Value	21268	Brazo*****
			3486	GT Di*****
			7822	Ag So*****
	45000-63145001-80890000-00000-0000-000000	Capital Improvement Fund-Project Management \- Capital-Vehicles-No Value-No Value-No Value	91345	CC Cr*****
	45000-63270000-80101000-00000-0000-000000	Capital Improvement Fund-County Administration Building-Building Improvements-No Value-No Value-No Value	101554	Dudle*****C
			101953	Plan *****ral Co
			102961	Tom G***** Engineers Inc
	45000-63310001-80101000-00000-0000-000000	Capital Improvement Fund-Juvenile Services \- Capital-Building Improvements-No Value-No Value-No Value	101932	Allen*****
	50000-64005000-71110000-00000-0000-000000	Health and Life Insurance Fund-Group Insurance \- Administration-	6313	Texas*****Counties

Payment Date	Account	Account Description	Supplier Number	Party Name
6/23/2026		Administrative Fee \- County-No Value-No Value-No Value		
	50000-64005000-71111000-00000-0000-000000	Health and Life Insurance Fund-Group Insurance \- Administration-Prescription Claims \- County-No Value-No Value-No Value	6313	Texas*****Counties
	50000-64005000-71112000-00000-0000-000000	Health and Life Insurance Fund-Group Insurance \- Administration-Medical Claims \- County-No Value-No Value-No Value	6313	Texas*****Counties
	50000-64005000-71113000-00000-0000-000000	Health and Life Insurance Fund-Group Insurance \- Administration-Dental Claims \- County-No Value-No Value-No Value	6313	Texas*****Counties
	50000-64005100-60380000-00000-0000-000000	Health and Life Insurance Fund-Health & Wellness Clinic-Health Supplies-No Value-No Value-No Value	93814	Henry*****
	50000-64005100-65540000-00000-0000-000000	Health and Life Insurance Fund-Health & Wellness Clinic-Copier/Printer/Fax Maintenance-No Value-No Value-No Value	9038	Xerox*****ons Southwest
	60000-00000000-31080000-00000-0000-000000	Payroll Fund-No Value-Basic Life Administrative Fee Payable-No Value-No Value-No Value	61875	Linco***** Insurance Company,
	60000-00000000-31210000-00000-0000-000000	Payroll Fund-No Value-Withholding \- Lincoln Financial Ins-No Value-No Value-No Value	61875	Linco***** Insurance Company,
	91000-53000100-65540000-00000-0000-000000	Health \- County Health District-Health Department \- Administration-Copier/Printer/Fax Maintenance-No Value-No Value-No Value	9038	Xerox*****ons Southwest
	91000-53000100-71025000-00000-0000-000000	Health \- County Health District-Health Department \- Administration-Contract Services-No Value-No Value-No Value	94324	Audio*****Inc
	91000-53001000-60600000-00000-0000-000000	Health \- County Health District-Environmental Services Administration-Office Supplies-No Value-No Value-No Value	9728	Wilto*****Ltd
	91000-53001000-60620000-00000-0000-000000	Health \- County Health District-Environmental Services Administration-Postage & Shipping-No Value-No Value-No Value	95832	UPS S*****
	91000-53001000-61500000-00000-0000-000000	Health \- County Health District-Environmental Services Administration-Printing-No Value-No Value-No Value	1229	Alpha*****
	91000-53001000-71020010-00000-0000-000000	Health \- County Health District-Environmental Services Administration-SBITA \- Principal-No Value-No Value-No Value	102223	Inspe*****
	91000-53003000-60380000-00000-0000-000000	Health \- County Health District-Lab Administration-Health Supplies-No	92898	Fishe*****pany LLC

Payment Date	Account	Account Description	Supplier Number	Party Name
6/23/2026	91000-53003000-60380000-00000-0000-000000	Health \- County Health District-Lab Administration-Health Supplies-No Value-No Value-No Value	92898	Fishe*****pany LLC
	91000-53003000-60500000-00000-0000-000000	Health \- County Health District-Lab Administration-Equipment & I.T. Enhancement-No Value-No Value-No Value	91018	Stapl*****mmercial Inc
	91000-53003000-65320000-00000-0000-000000	Health \- County Health District-Lab Administration-Equipment Maintenance-No Value-No Value-No Value	101897	Micro*****Service
	91000-53003000-71025000-00000-0000-000000	Health \- County Health District-Lab Administration-Contract Services-No Value-No Value-No Value	96352	Biome*****tions LLC
	91000-531000-60380000-00000-0000-000000	Health \- County Health District-Immunization-Health Supplies-No Value-No Value-No Value	93814	Henry*****
	91000-531000-61620000-00000-0000-000000	Health \- County Health District-Immunization-Subscriptions & Publications-No Value-No Value-No Value	96271	Contr*****
	91000-531300-72590000-00000-0000-000000	Health \- County Health District-Breast and Cervical Cancer Services Grant-Professional Fees \- Other-No Value-No Value-No Value	94803	Expre*****
	91000-532300-60360000-00000-0000-000000	Health \- County Health District-Maternal, Child & Adolescent Health Grant-Furniture Expense-No Value-No Value-No Value	97596	Amazo*****
	91000-532300-60600000-00000-0000-000000	Health \- County Health District-Maternal, Child & Adolescent Health Grant-Office Supplies-No Value-No Value-No Value	97596	Amazo*****
	91000-535000-61801000-00000-0000-000000	Health \- County Health District-Texas Healthy Communities-Travel-No Value-No Value-No Value	Employee	John *****
	91000-536000-61500000-00000-0000-000000	Health \- County Health District-Regional Programming-Printing-No Value-No Value-No Value	1229 802008	Alpha***** Monog*****
	97000-551100-69102000-00000-0000-000000	CSCD \- Community Supervision-Basic Supervision-Vehicle Maintenance\-\-CSCD-No Value-No Value-No Value	21268	Brazo*****
	97000-551100-69302000-00000-0000-000000	CSCD \- Community Supervision-Basic Supervision-Conference & Seminar Fees\-\-CSCD-No Value-No Value-No Value	97572	Every*****me Inc
	97000-551100-69308000-00000-0000-000000	CSCD \- Community Supervision-Basic Supervision-Professional Fees \- Other\-\-CSCD-No Value-No Value-No Value	19886	Lexis*****ions
	97000-551100-69309000-00000-0000-000000	CSCD \- Community Supervision-Basic Supervision-Security Services-No Value-No Value-No Value	102351	TNT S*****s LLC

Payment Date	Account	Account Description	Supplier Number	Party Name
6/23/2026	97000-551100-69400000-00000-0000-000000	CSCD \- Community Supervision-Basic Supervision-Office Supplies\CSCD-No Value-No Value-No Value	21468	Sassi*****
Grand Total				



**BRAZOS COUNTY
BRYAN, TEXAS**

DEPARTMENT: Human Resources NUMBER:
DATE OF COURT MEETING: 6/23/2026
ITEM: Acknowledgment of Personnel Change of Status.
TO: Commissioners Court
DATE: 06/15/2026
FISCAL IMPACT: False
BUDGETED: False
DOLLAR AMOUNT: \$0.00

NOTES/EXCEPTIONS: Human Resources is requesting the approval of the following Personnel Action Forms (PAFs). A list of departments is included on the attached coversheet. All positions have been reviewed and verified that they fall within budget guidelines. Consequence of non-approval would be to the employee pay and/or position.

ATTACHMENTS:

File Name

[EO Cover Page.pdf](#)

Description

Cover Sheet

Type

Cover Memo

Personnel Change of Status for Elected Officials

(Jun 15, 2026)

Commissioners' Court Date: 06-23-202
 Department Submitting Information: Human Resources
 Purpose of Submissions: Consider and Take Action on Change

Employment

Department Name	Employee Name
Sheriff Office - Jail Administration	Brosnan, James
Sheriff Office - Jail Administration	Lopez, Francisco*
Specialty Court - Mental Health	Baker, Bobby

Separations

Department Name	Employee Name
272nd District Court - Administration	Ybarra, Jacaline
District Attorney - Administration	Golden, Ryan
Tax Assessor - Collector - Administration	Lowery, Tori

Personnel Change of Status

Department Name	Employee Name
County Attorney - Administration	Butler, Robert
County Attorney - Administration	Grisham, John
County Attorney - Administration	Minahan, John
County Attorney - Administration	Ocampo Banos, Brisa
Justice of the Peace - Precinct 1 - Administration	Malinak, Katrina
Justice of the Peace - Precinct 1 - Administration	Ponce, Maria
Sheriff Office - Jail Administration	Broussard, Avery
Sheriff Office - Jail Administration	Chesterfield, Cassie
Sheriff Office - Jail Administration	Dodgen, Kenneth
Sheriff Office - Jail Administration	Fisher, Michael
Sheriff Office - Jail Administration	Gultron, Juan
Sheriff Office - Jail Administration	Guthrie, Jordan
Sheriff Office - Jail Administration	Hales, Brian
Sheriff Office - Jail Administration	Jiang, Devin
Sheriff Office - Jail Administration	Kelley, Ke'Asia
Sheriff Office - Jail Administration	Kmiec, Keenan
Sheriff Office - Jail Administration	Lopez, Francisco
Sheriff Office - Jail Administration	Lyle, Kelsey
Sheriff Office - Jail Administration	Ramon, Aston
Sheriff Office - Jail Administration	Randall, Aidan
Sheriff Office - Jail Administration	Robinson, Robert
Sheriff Office - Jail Administration	Russell, David
Sheriff Office - Jail Administration	Scroggins, Joseph
Sheriff Office - Jail Administration	Sims, William

Sheriff Office - Jail Administration	Terrazas, Jonathan
Sheriff Office - Jail Administration	Wilcox, Eric
Sheriff Office - Jail Administration	Wilson, Amber

Approved in Commissioners' Court: 06-23-2026

County Judge's or Commissioner's Signature: _____

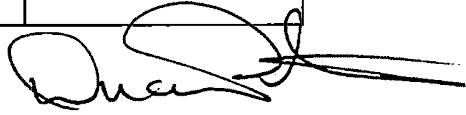
A handwritten signature in black ink, appearing to be "Jonathan Terrazas", written over the signature line.



**BRAZOS COUNTY
BRYAN, TEXAS**

DEPARTMENT:

NUMBER:

DATE OF COURT MEETING: 6/23/2026

ITEM: Acknowledgement that the Brazos County Emergency Services District #3 (ESD #3) Bond was filed with the Brazos County Clerk's Office on June 8, 2026.

TO: Commissioners Court

DATE: 06/08/2026

FISCAL IMPACT: False

BUDGETED: False

DOLLAR AMOUNT: \$0.00

ATTACHMENTS:

File Name

[image5378.pdf](#)

Description

ESD #3 Bond

Type

Cover Memo

MERCHANTS BONDING COMPANY™

MERCHANTS NATIONAL BONDING, INC. P.O. BOX 14498, DES MOINES, IA 50306-3498
PHONE: (800) 678-8171 FAX: (515) 243-3854

FILED FOR RECORD
DATE 6-8-2026
AT 9:50 O'CLOCK A.M.

TEXAS OFFICIAL BOND AND OATH

KAREN MCQUEEN
BRAZOS COUNTY CLERK
Bond No. 101846092
By Ashley Felus Boman

THE STATE OF TEXAS }
County of Brazos } ss.
KNOW ALL PERSONS BY THESE PRESENTS:

That we, Doug Box, as Principal, and the Merchants National Bonding, Inc., a corporation duly licensed to do business in the State of Texas, as Surety, are held and bound unto Brazos County ESD #3, his successors in office, in the sum of One Hundred Thousand Dollars (\$100,000.00) DOLLARS, for the payment of which we hereby bind ourselves and our heirs, executors and administrators, jointly and severally, by these presents.

THE CONDITION OF THE ABOVE OBLIGATION is such, that, whereas, the above bounden Principal was on the 18th day of February, 2025, duly Appointed to the office of Treasurer in and for Brazos County in the State of Texas, for a term beginning the 10th day of April, 2026 and ending the 10th day of April, 2027.

Now, therefore, if the said Principal shall well and faithfully perform and discharge all the duties required of him by law as the aforesaid officer, and shall Faithfully perform the duties of office

then this obligation to be void, otherwise to remain in full force and effect.

PROVIDED, HOWEVER, that regardless of the number of years this bond may remain in force and the number of claims which may be made against this bond, the liability of the Surety shall not be cumulative and the aggregate liability of the Surety for any and all claims, suits, or actions under this bond shall not exceed the amount stated above. Any revision of the bond amount shall not be cumulative.

PROVIDED, FURTHER, that this bond may be canceled by the Surety by sending written notice to the party to whom this bond is payable stating that, not less than thirty (30) days thereafter, the Surety's liability hereunder shall terminate as to subsequent acts of the Principal.

Dated this 16th day of April, 2026.

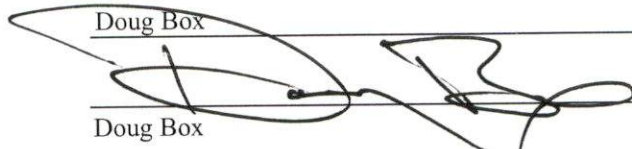
Doug Box Principal

Doug Box
Merchants National Bonding, Inc.
By: Leah Rex
Leah Rex Attorney-in-Fact

ACKNOWLEDGEMENT OF PRINCIPAL

THE STATE OF TEXAS }
County of Brazos } ss.

Before me, Zachary Eison, a notary public, on this day personally appeared Doug Box known to me to be the person whose name is subscribed to the foregoing instrument, and acknowledged to me that he/she executed the same for the purposes and consideration therein expressed.

Given under my hand and seal of office, at Postal Plus (3708 E. 29th St, Bryan TX, 77802) this 24th day of April, 2026

Zachary Eison
Brazos County, Texas.

SEAL
PO 0123 TX (2/15)

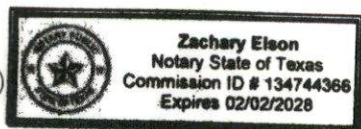

MERCHANTS BONDING COMPANY™ POWER OF ATTORNEY

Know All Persons By These Presents, that MERCHANTS BONDING COMPANY (MUTUAL) and MERCHANTS NATIONAL BONDING, INC., both being corporations of the State of Iowa, and MERCHANTS NATIONAL INDEMNITY COMPANY, an assumed name of Merchants National Bonding, Inc., (herein collectively called the "Companies") do hereby make, constitute and appoint, individually,

Leah Rex

their true and lawful Attorney(s)-in-Fact, to sign its name as surety(ies) and to execute, seal and acknowledge any and all bonds, undertakings, contracts and other written instruments in the nature thereof, on behalf of the Companies in their business of guaranteeing the fidelity of persons, guaranteeing the performance of contracts and executing or guaranteeing bonds and undertakings required or permitted in any actions or proceedings allowed by law.

This Power-of-Attorney is granted and is signed and sealed by facsimile under and by authority of the By-Laws adopted by the Board of Directors of the Companies.

"The President, Secretary, Treasurer, or any Assistant Treasurer or any Assistant Secretary or any Vice President shall have power and authority to appoint Attorneys-in-Fact, and to authorize them to execute on behalf of the Company, and attach the seal of the Company thereto, bonds and undertakings, recognizances, contracts of indemnity and other writings obligatory in the nature thereof."

"The signature of any authorized officer and the seal of the Company may be affixed by facsimile or electronic transmission to any Power of Attorney or Certification thereof authorizing the execution and delivery of any bond, undertaking, recognizance, or other suretyship obligations of the Company, and such signature and seal when so used shall have the same force and effect as though manually fixed."

In connection with obligations in favor of the Florida Department of Transportation only, it is agreed that the power and authority hereby given to the Attorney-in-Fact includes any and all consents for the release of retained percentages and/or final estimates on engineering and construction contracts required by the State of Florida Department of Transportation. It is fully understood that consenting to the State of Florida Department of Transportation making payment of the final estimate to the Contractor and/or its assignee, shall not relieve this surety company of any of its obligations under its bond.

In connection with obligations in favor of the Kentucky Department of Highways only, it is agreed that the power and authority hereby given to the Attorney-in-Fact cannot be modified or revoked unless prior written personal notice of such intent has been given to the Commissioner - Department of Highways of the Commonwealth of Kentucky at least thirty (30) days prior to the modification or revocation.

In Witness Whereof, the Companies have caused this instrument to be signed and sealed this 16th day of April, 2026.

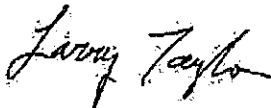

MERCHANTS BONDING COMPANY (MUTUAL)
MERCHANTS NATIONAL BONDING, INC.
MERCHANTS NATIONAL INDEMNITY COMPANY

By 
President

STATE OF IOWA
COUNTY OF DALLAS ss.

On this 16th day of April, 2026, before me appeared Larry Taylor, to me personally known, who being by me duly sworn did say that he is President of MERCHANTS BONDING COMPANY (MUTUAL), MERCHANTS NATIONAL BONDING, INC., and MERCHANTS NATIONAL INDEMNITY COMPANY; and that the seals affixed to the foregoing instrument are the Corporate Seals of the Companies; and that the said instrument was signed and sealed in behalf of the Companies by authority of their respective Boards of Directors.

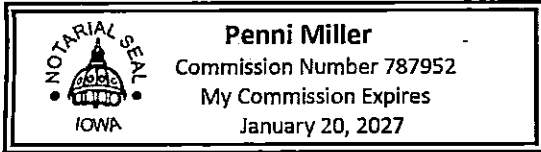

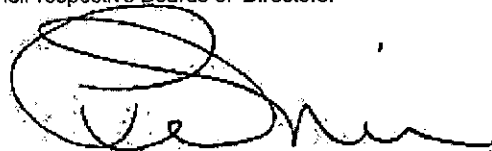

Notary Public

(Expiration of notary's commission does not invalidate this instrument)

I, Elisabeth Sandersfeld, Secretary of MERCHANTS BONDING COMPANY (MUTUAL), MERCHANTS NATIONAL BONDING, INC., and MERCHANTS NATIONAL INDEMNITY COMPANY do hereby certify that the above and foregoing is a true and correct copy of the POWER-OF-ATTORNEY executed by said Companies, which is still in full force and effect and has not been amended or revoked.

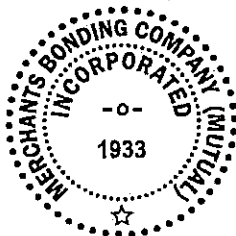
In Witness Whereof, I have hereunto set my hand and affixed the seal of the Companies on this 16th day of April, 2026.



Secretary



**BRAZOS COUNTY
BRYAN, TEXAS**

DEPARTMENT: Budget Office NUMBER:

DATE OF COURT MEETING: 6/23/2026

ITEM: Acknowledgement of FY 2025-2026 Budget to Actuals by Fund as of June 11, 2026.
Acknowledgement of FY 2025-2026 Contingency Budget to Actuals by Fund as of June 11, 2026.

TO: Commissioners Court

FROM: Nina Payne

DATE: 06/11/2026

FISCAL IMPACT: False

BUDGETED: False

DOLLAR AMOUNT: \$0.00

ATTACHMENTS:

<u>File Name</u>	<u>Description</u>	<u>Type</u>
FY_26_Budget_to_Actuals_by_Fund.pdf	FY 2025-2026 Budget to Actuals by Fund as of 6/11/2026	Backup Material
FY_26_Contingency_Budget_to_Actuals_Fund.pdf	FY 2025-2026 Contingency Budget to Actuals by Fund as of 6/11/2026	Backup Material

Brazos County, Texas
FY 2025-2026 Budget to Actuals -
Revenue and Expenditure
Categories Report by Fund
(Unaudited)

Fund: 01000 General Fund

Description	2023-2024 Actual Revenue	2024-2025 Actual Revenue	2025-2026 Adopted Budget	2025-2026 Actual Revenue To Date	Percent Received
Taxes	131,167,122	140,005,653	152,952,050	133,667,962	87%
Charges for Services	13,985,011	14,649,857	13,835,017	10,850,101	78%
Interest Income	12,656,049	11,857,040	7,200,000	6,394,914	89%
Other Revenue	2,820,246	1,620,893	1,069,200	912,158	85%
Reserves	0	-	94,252,872	-	-
Intergovernmental	968,398	1,081,611	821,080	919,865	112%
Other Financing Sources	190,452	147,893	210,000	4,926,649	2,346%
Total Revenue	\$161,787,279	\$169,362,948	\$270,340,219	\$157,671,648	58%

Description	2023-2024 Actual Expenditures	2024-2025 Actual Expenditures	2025-2026 Adopted Budget	2025-2026 Expenditures to Date	Percent Spent
Salaries and Wages	57,114,903	62,574,192	69,426,458	42,099,019	61%
Outside Labor Costs	177,763	108,225	163,000	130,322	80%
Benefits	31,575,201	33,486,046	39,347,053	22,871,686	58%
Supplies and Other Charges	9,412,807	10,107,933	11,980,660	7,720,877	64%
Contingency	-	-	6,578,715	-	-
Repairs and Maintenance	9,794,592	10,478,816	21,817,233	6,417,061	29%
Contractual Services	8,872,895	9,705,326	11,719,510	7,769,265	66%
Professional Services	7,516,511	6,475,636	12,222,810	4,370,187	36%
Community Contracts	5,616,842	6,319,276	8,548,699	5,758,897	67%
Capital Outlay	7,220,517	2,024,485	10,900,000	2,143,397	20%
Other Financing Uses	478,638	17,551,071	77,636,081	59,329,430	76%
Total Expense	\$137,780,669	\$158,831,006	\$270,340,219	\$158,610,142	59%

Brazos County, Texas
FY 2025-2026 Budget to Actuals -
Revenue and Expenditure
Categories Report by Fund
(Unaudited)

Fund: 11000 Hotel Occupancy Tax Fund

Description	2023-2024 Actual Revenue	2024-2025 Actual Revenue	2025-2026 Adopted Budget	2025-2026 Actual Revenue To Date	Percent Received
Taxes	4,087,515	4,217,902	3,919,000	2,463,941	63%
Interest Income	318,887	412,365	315,000	214,892	68%
Other Revenue	2,750	-	-	-	-
Reserves	-	-	1,761,611	-	-
Other Financing Sources	46,707	4,385	-	-	-
Total Revenue	\$4,455,859	\$4,634,652	\$5,995,611	\$2,678,833	45%

Description	2023-2024 Actual Expenditures	2024-2025 Actual Expenditures	2025-2026 Adopted Budget	2025-2026 Expenditures to Date	Percent Spent
Salaries and Wages	75,019	127,203	177,830	102,143	57%
Benefits	36,337	56,871	78,806	47,830	61%
Supplies and Other Charges	32,748	119,943	70,375	17,995	26%
Contingency	-	-	500,000	-	-
Repairs and Maintenance	-	-	1,502,600	-	-
Contractual Services	175,950	183,536	210,500	127,307	60%
Professional Services	5,300	130,790	1,055,500	265,366	25%
Community Contracts	1,110,866	1,247,399	1,050,000	551,240	52%
Capital Outlay	563,572	44,287	100,000	0	0%
Other Financing Uses	1,250,000	1,250,000	1,250,000	1,250,000	100%
Total Expense	\$3,249,791	\$3,160,029	\$5,995,611	\$2,361,881	39%

**Brazos County, Texas
 FY 2025-2026 Budget to Actuals -
 Revenue and Expenditure
 Categories Report by Fund
 (Unaudited)**

Fund: 12000 State Lateral Road Fund

Description	2023-2024 Actual Revenue	2024-2025 Actual Revenue	2025-2026 Adopted Budget	2025-2026 Actual Revenue To Date	Percent Received
Interest Income	13,763	8,004	6,500	4,218	65%
Reserves	-	-	136,191	-	-
Intergovernmental	29,508	29,502	29,000	29,519	102%
Total Revenue	\$43,271	\$37,507	\$171,691	\$33,736	20%

Description	2023-2024 Actual Expenditures	2024-2025 Actual Expenditures	2025-2026 Adopted Budget	2025-2026 Expenditures to Date
Repairs and Maintenance	-	165,000	171,691	-
Total Expense	-	\$165,000	\$171,691	-

**Brazos County, Texas
 FY 2025-2026 Budget to Actuals -
 Revenue and Expenditure
 Categories Report by Fund
 (Unaudited)**

Fund: 13000 Unclaimed Property Fund

Description	2023-2024 Actual Revenue	2024-2025 Actual Revenue	2025-2026 Adopted Budget	2025-2026 Actual Revenue To Date	Percent Received
Interest Income	23,062	26,137	21,500	14,511	67%
Reserves	-	-	125,397	-	-
Total Revenue	\$23,062	\$26,137	\$146,897	\$14,511	10%

Description	2023-2024 Actual Expenditures	2024-2025 Actual Expenditures	2025-2026 Adopted Budget	2025-2026 Expenditures to Date
Supplies and Other Charges	-	-	2,000	-
Contingency	-	-	144,897	-
Total Expense	-	-	\$146,897	-

**Brazos County, Texas
 FY 2025-2026 Budget to Actuals -
 Revenue and Expenditure
 Categories Report by Fund
 (Unaudited)**

Fund: 15000 Law Library Fund

Description	2023-2024 Actual Revenue	2024-2025 Actual Revenue	2025-2026 Adopted Budget	2025-2026 Actual Revenue To Date	Percent Received
Charges for Services	105,074	120,585	114,560	67,803	59%
Interest Income	8,101	11,021	8,000	6,140	77%
Reserves	-	-	247,268	-	-
Total Revenue	\$113,175	\$131,606	\$369,828	\$73,943	20%

Description	2023-2024 Actual Expenditures	2024-2025 Actual Expenditures	2025-2026 Adopted Budget	2025-2026 Expenditures to Date	Percent Spent
Supplies and Other Charges	65,385	67,876	369,828	45,194	12%
Total Expense	\$65,385	\$67,876	\$369,828	\$45,194	12%

**Brazos County, Texas
 FY 2025-2026 Budget to Actuals -
 Revenue and Expenditure
 Categories Report by Fund
 (Unaudited)**

Fund: 16000 Local Provider Participation
 Fund

Description	2023-2024 Actual Revenue	2024-2025 Actual Revenue	2025-2026 Adopted Budget	2025-2026 Actual Revenue To Date	Percent Received
Taxes	40,008,694	47,803,716	42,470,000	46,018,947	108%
Interest Income	1,392,213	1,148,426	1,045,000	542,889	52%
Other Revenue	487,494	79,569	0	-	-
Reserves	-	-	23,023,800	-	-
Total Revenue	\$41,888,401	\$49,031,711	\$66,538,800	\$46,561,836	70%

Description	2023-2024 Actual Expenditures	2024-2025 Actual Expenditures	2025-2026 Adopted Budget	2025-2026 Expenditures to Date	Percent Spent
Community Contracts	37,357,270	51,598,849	66,518,800	27,624,579	42%
Other Financing Uses	20,000	20,000	20,000	20,000	100%
Total Expense	\$37,377,270	\$51,618,849	\$66,538,800	\$27,644,579	42%

Brazos County, Texas
FY 2025-2026 Budget to Actuals -
Revenue and Expenditure
Categories Report by Fund
(Unaudited)

Fund: 18000 Law Enforcement Education
Fund

Description	2023-2024 Actual Revenue	2024-2025 Actual Revenue	2025-2026 Adopted Budget	2025-2026 Actual Revenue To Date	Percent Received
Reserves	-	-	107,850	-	-
Intergovernmental	37,584	42,779	42,750	42,991	101%
Total Revenue	\$37,584	\$42,779	\$150,600	\$42,991	29%

Description	2023-2024 Actual Expenditures	2024-2025 Actual Expenditures	2025-2026 Adopted Budget	2025-2026 Expenditures to Date	Percent Spent
Supplies and Other Charges	25,911	17,202	150,600	18,215	12%
Contractual Services	-	-	-	5,488	-
Total Expense	\$25,911	\$17,202	\$150,600	\$23,703	16%

Brazos County, Texas
FY 2025-2026 Budget to Actuals -
Revenue and Expenditure
Categories Report by Fund
(Unaudited)

Fund: 19000 Court Records Preservation
Fund

Description	2023-2024 Actual Revenue	2024-2025 Actual Revenue	2025-2026 Adopted Budget	2025-2026 Actual Revenue To Date
Charges for Services	410	0	-	-
Interest Income	36,545	0	-	-
Total Revenue	\$36,955	\$0	-	-

Description	2023-2024 Actual Expenditures	2024-2025 Actual Expenditures	2025-2026 Adopted Budget	2025-2026 Expenditures to Date
Other Financing Uses	-	702,725	-	-
Total Expense	-	\$702,725	-	-

Brazos County, Texas
FY 2025-2026 Budget to Actuals -
Revenue and Expenditure
Categories Report by Fund
(Unaudited)

Fund: 20000 County Clerk Records
Management Fund

Description	2023-2024 Actual Revenue	2024-2025 Actual Revenue	2025-2026 Adopted Budget	2025-2026 Actual Revenue To Date	Percent Received
Charges for Services	305,258	320,659	300,000	215,768	72%
Interest Income	69,629	73,116	55,000	36,234	66%
Reserves	-	-	1,362,140	-	-
Total Revenue	\$374,888	\$393,774	\$1,717,140	\$252,002	15%

Description	2023-2024 Actual Expenditures	2024-2025 Actual Expenditures	2025-2026 Adopted Budget	2025-2026 Expenditures to Date	Percent Spent
Salaries and Wages	124,374	133,395	140,014	90,296	64%
Benefits	62,648	66,346	86,618	44,584	51%
Supplies and Other Charges	17,345	6,695	8,500	105	1%
Contingency	-	-	1,056,168	-	-
Repairs and Maintenance	-	-	500	657	131%
Contractual Services	133,123	77,016	425,340	15,809	4%
Capital Outlay	22,822	-	-	-	-
Total Expense	\$360,313	\$283,452	\$1,717,140	\$151,451	9%

Brazos County, Texas
FY 2025-2026 Budget to Actuals -
Revenue and Expenditure
Categories Report by Fund
(Unaudited)

Fund: 20010 County Clerk Archival Fund

Description	2023-2024 Actual Revenue	2024-2025 Actual Revenue	2025-2026 Adopted Budget	2025-2026 Actual Revenue To Date	Percent Received
Charges for Services	280,855	301,845	295,000	201,930	68%
Interest Income	74,394	86,971	63,000	42,645	68%
Reserves	-	-	1,758,000	-	-
Total Revenue	\$355,249	\$388,816	\$2,116,000	\$244,575	12%

Description	2023-2024 Actual Expenditures	2024-2025 Actual Expenditures	2025-2026 Adopted Budget	2025-2026 Expenditures to Date	Percent Spent
Contingency	-	-	1,541,000	-	-
Contractual Services	220,953	263,277	575,000	197,561	34%
Total Expense	\$220,953	\$263,277	\$2,116,000	\$197,561	9%

Brazos County, Texas
FY 2025-2026 Budget to Actuals -
Revenue and Expenditure
Categories Report by Fund
(Unaudited)

Fund: 22000 Courthouse Security Fund

Description	2023-2024 Actual Revenue	2024-2025 Actual Revenue	2025-2026 Adopted Budget	2025-2026 Actual Revenue To Date	Percent Received
Charges for Services	89,005	110,055	114,600	72,626	63%
Interest Income	6,601	11,321	5,000	6,952	139%
Reserves	-	-	268,277	-	-
Total Revenue	\$95,606	\$121,375	\$387,877	\$79,578	21%

Description	2023-2024 Actual Expenditures	2024-2025 Actual Expenditures	2025-2026 Adopted Budget	2025-2026 Expenditures to Date	Percent Spent
Supplies and Other Charges	2,936	7,648	2,510	2,927	117%
Contingency	-	-	300,702	-	-
Repairs and Maintenance	4,633	1,243	20,000	1,274	6%
Contractual Services	-	450	53,514	47,808	89%
Community Contracts	1,062	1,158	1,151	893	78%
Capital Outlay	6,263	-	10,000	-	-
Total Expense	\$14,895	\$10,499	\$387,877	\$52,902	14%

**Brazos County, Texas
 FY 2025-2026 Budget to Actuals -
 Revenue and Expenditure
 Categories Report by Fund
 (Unaudited)**

Fund: 22010 Justice Court Security Fund

Description	2023-2024 Actual Revenue	2024-2025 Actual Revenue	2025-2026 Adopted Budget	2025-2026 Actual Revenue To Date	Percent Received
Charges for Services	35,820	21,537	8,800	6,835	78%
Interest Income	12,673	14,872	10,750	7,530	70%
Reserves	-	-	294,318	-	-
Total Revenue	\$48,492	\$36,409	\$313,868	\$14,364	5%

Description	2023-2024 Actual Expenditures	2024-2025 Actual Expenditures	2025-2026 Adopted Budget	2025-2026 Expenditures to Date
Repairs and Maintenance	-	-	60,000	-
Contractual Services	-	-	30,000	-
Professional Services	-	-	60,000	-
Capital Outlay	-	-	163,868	-
Total Expense	-	-	\$313,868	-

Brazos County, Texas
FY 2025-2026 Budget to Actuals -
Revenue and Expenditure
Categories Report by Fund
(Unaudited)

Fund: 23000 District Clerk Records
Management Fund

Description	2023-2024 Actual Revenue	2024-2025 Actual Revenue	2025-2026 Adopted Budget	2025-2026 Actual Revenue To Date	Percent Received
Charges for Services	126,480	153,496	135,000	94,073	70%
Interest Income	14,174	56,366	40,000	24,112	60%
Reserves	-	-	1,042,786	-	-
Other Financing Sources	-	702,725	-	-	-
Total Revenue	\$140,653	\$912,588	\$1,217,786	\$118,185	10%

Description	2023-2024 Actual Expenditures	2024-2025 Actual Expenditures	2025-2026 Adopted Budget	2025-2026 Expenditures to Date	Percent Spent
Salaries and Wages	60,195	61,627	81,012	26,117	32%
Benefits	4,718	15,275	20,400	6,471	32%
Supplies and Other Charges	-	-	-	2,928	-
Contractual Services	-	178,673	1,096,374	78,183	7%
Professional Services	-	-	20,000	-	-
Total Expense	\$64,914	\$255,575	\$1,217,786	\$113,699	9%

**Brazos County, Texas
 FY 2025-2026 Budget to Actuals -
 Revenue and Expenditure
 Categories Report by Fund
 (Unaudited)**

Fund: 23010 District Clerk Archival Fund

Description	2023-2024 Actual Revenue	2024-2025 Actual Revenue	2025-2026 Adopted Budget	2025-2026 Actual Revenue To Date
Charges for Services	320	95	-	-
Interest Income	75	75	-	-
Total Revenue	\$395	\$170	-	-

Description	2023-2024 Actual Expenditures	2024-2025 Actual Expenditures	2025-2026 Adopted Budget	2025-2026 Expenditures to Date
Professional Services	-	1,774	-	-
Total Expense	-	\$1,774	-	-

Brazos County, Texas
FY 2025-2026 Budget to Actuals -
Revenue and Expenditure
Categories Report by Fund
(Unaudited)

Fund: 24000 Justice of the Peace
 Technology Fund

Description	2023-2024 Actual Revenue	2024-2025 Actual Revenue	2025-2026 Adopted Budget	2025-2026 Actual Revenue To Date	Percent Received
Charges for Services	30,068	28,858	27,550	21,707	79%
Interest Income	10,515	4,660	3,300	2,634	80%
Reserves	-	-	102,888	-	-
Total Revenue	\$40,584	\$33,518	\$133,738	\$24,341	18%

Description	2023-2024 Actual Expenditures	2024-2025 Actual Expenditures	2025-2026 Adopted Budget	2025-2026 Expenditures to Date	Percent Spent
Supplies and Other Charges	13,388	9,481	51,200	2,933	6%
Contingency	-	-	73,738	-	-
Contractual Services	-	-	8,800	-	-
Capital Outlay	148,938	-	-	-	-
Total Expense	\$162,326	\$9,481	\$133,738	\$2,933	2%

Brazos County, Texas
FY 2025-2026 Budget to Actuals -
Revenue and Expenditure
Categories Report by Fund
(Unaudited)

Fund: 24010 County and District Court
 Technology Fund

Description	2023-2024 Actual Revenue	2024-2025 Actual Revenue	2025-2026 Adopted Budget	2025-2026 Actual Revenue To Date	Percent Received
Charges for Services	8,304	8,424	8,200	5,548	68%
Interest Income	6,831	7,583	6,000	3,876	65%
Reserves	-	-	150,778	-	-
Total Revenue	\$15,135	\$16,008	\$164,978	\$9,425	6%

Description	2023-2024 Actual Expenditures	2024-2025 Actual Expenditures	2025-2026 Adopted Budget	2025-2026 Expenditures to Date
Supplies and Other Charges	-	-	164,978	-
Total Expense	-	-	\$164,978	-

**Brazos County, Texas
 FY 2025-2026 Budget to Actuals -
 Revenue and Expenditure
 Categories Report by Fund
 (Unaudited)**

Fund: 25000 Forfeiture Fund

Description	2023-2024 Actual Revenue	2024-2025 Actual Revenue	2025-2026 Adopted Budget	2025-2026 Actual Revenue To Date	Percent Received
Charges for Services	304	44,836	-	5,526	-
Interest Income	1,965	4,049	-	2,158	-
Reserves	-	-	81,476	-	-
Total Revenue	\$2,269	\$48,886	\$81,476	\$7,684	9%

Description	2023-2024 Actual Expenditures	2024-2025 Actual Expenditures	2025-2026 Adopted Budget	2025-2026 Expenditures to Date
Supplies and Other Charges	235	3,878	64,824	-
Contingency	-	-	16,652	-
Total Expense	\$235	\$3,878	\$81,476	-

Brazos County, Texas
FY 2025-2026 Budget to Actuals -
Revenue and Expenditure
Categories Report by Fund
(Unaudited)

Fund: 26000 District Attorney Hot Check
 Collections Fund

Description	2023-2024 Actual Revenue	2024-2025 Actual Revenue	2025-2026 Adopted Budget	2025-2026 Actual Revenue To Date	Percent Received
Interest Income	277	298	200	149	75%
Other Revenue	75	225	150	75	50%
Reserves	-	-	5,935	-	-
Total Revenue	\$352	\$523	\$6,285	\$224	4%

Description	2023-2024 Actual Expenditures	2024-2025 Actual Expenditures	2025-2026 Adopted Budget	2025-2026 Expenditures to Date
Contingency	-	-	6,285	-
Total Expense	-	-	\$6,285	-

**Brazos County, Texas
 FY 2025-2026 Budget to Actuals -
 Revenue and Expenditure
 Categories Report by Fund
 (Unaudited)**

Fund: 27000 Bail Bond Board Fund

Description	2023-2024 Actual Revenue	2024-2025 Actual Revenue	2025-2026 Adopted Budget	2025-2026 Actual Revenue To Date	Percent Received
Interest Income	5,975	6,292	4,800	3,107	65%
Other Revenue	2,500	2,000	2,500	1,500	60%
Reserves	-	-	122,541	-	-
Total Revenue	\$8,475	\$8,292	\$129,841	\$4,607	4%

Description	2023-2024 Actual Expenditures	2024-2025 Actual Expenditures	2025-2026 Adopted Budget	2025-2026 Expenditures to Date
Salaries and Wages	-	-	4,001	-
Benefits	-	-	1,016	-
Supplies and Other Charges	419	1,718	7,660	-
Contingency	-	-	117,164	-
Total Expense	\$419	\$1,718	\$129,841	-

Brazos County, Texas
FY 2025-2026 Budget to Actuals -
Revenue and Expenditure
Categories Report by Fund
(Unaudited)

Fund: 29000 Vehicle Inventory Interest
Fund

Description	2023-2024 Actual Revenue	2024-2025 Actual Revenue	2025-2026 Adopted Budget	2025-2026 Actual Revenue To Date	Percent Received
Taxes	2,465	2,335	2,500	3,285	131%
Interest Income	53,643	58,617	44,000	32,862	75%
Reserves	-	-	452,305	-	-
Total Revenue	\$56,108	\$60,953	\$498,805	\$36,147	7%

Description	2023-2024 Actual Expenditures	2024-2025 Actual Expenditures	2025-2026 Adopted Budget	2025-2026 Expenditures to Date	Percent Spent
Salaries and Wages	-	-	11,100	-	-
Benefits	-	-	2,822	-	-
Supplies and Other Charges	2,196	3,461	26,750	1,216	5%
Contingency	-	-	427,633	-	-
Repairs and Maintenance	-	-	1,000	-	-
Contractual Services	-	-	2,000	-	-
Professional Services	-	-	7,500	-	-
Capital Outlay	-	-	20,000	-	-
Total Expense	\$2,196	\$3,461	\$498,805	\$1,216	0%

**Brazos County, Texas
 FY 2025-2026 Budget to Actuals -
 Revenue and Expenditure
 Categories Report by Fund
 (Unaudited)**

Fund: 30000 Brazos County Grant Fund

Description	2023-2024 Actual Revenue	2024-2025 Actual Revenue	2025-2026 Adopted Budget	2025-2026 Actual Revenue To Date	Percent Received
Public Health Revenue	60,000	-	-	-	-
Other Revenue	-	-	-	160,000	-
Intergovernmental	4,272,026	4,229,734	5,390,103	3,144,792	58%
Other Financing Sources	478,638	1,162,822	2,033,115	329,430	16%
Total Revenue	\$4,810,663	\$5,392,556	\$7,423,218	\$3,634,222	49%

Description	2023-2024 Actual Expenditures	2024-2025 Actual Expenditures	2025-2026 Adopted Budget	2025-2026 Expenditures to Date	Percent Spent
Salaries and Wages	2,794,329	3,352,965	4,765,856	2,637,575	55%
Benefits	1,211,302	1,372,457	1,994,530	1,045,223	52%
Supplies and Other Charges	176,139	178,669	250,162	118,703	47%
Contingency	-	-	12,329	-	-
Repairs and Maintenance	3,637	5,206	5,750	504	9%
Contractual Services	403,012	229,747	117,091	116,400	99%
Professional Services	2,500	5,350	277,500	64,250	23%
Capital Outlay	377,396	248,162	-	-	-
Total Expense	\$4,968,314	\$5,392,556	\$7,423,218	\$3,982,655	54%

**Brazos County, Texas
 FY 2025-2026 Budget to Actuals -
 Revenue and Expenditure
 Categories Report by Fund
 (Unaudited)**

Fund: 31000 American Rescue Plan Act

Description	2023-2024 Actual Revenue	2024-2025 Actual Revenue	2025-2026 Adopted Budget	2025-2026 Actual Revenue To Date
Reserves	-	-	14,965,220	-
Intergovernmental	1,509,822	13,078,112	10,110,124	-
Other Financing Sources	-	15,610,777	470,000	-
Total Revenue	\$1,509,822	\$28,688,889	\$25,545,344	-

Description	2023-2024 Actual Expenditures	2024-2025 Actual Expenditures	2025-2026 Adopted Budget	2025-2026 Expenditures to Date	Percent Spent
Expenditures Budgeted in Excess of Actual	(478,903)	-	-	-	-
Supplies and Other Charges	(5,180)	-	-	63,461	-
Repairs and Maintenance	-	-	-	4,237	-
Contractual Services	813,154	8,920	695,766	272,317	39%
Capital Outlay	1,180,752	14,616,239	24,849,578	11,861,429	48%
Total Expense	\$1,509,822	\$14,625,159	\$25,545,344	\$12,201,443	48%

Brazos County, Texas
FY 2025-2026 Budget to Actuals -
Revenue and Expenditure
Categories Report by Fund
(Unaudited)

Fund: 32000 SB 22 2023 Rural Law
 Enforcement Salary Assistance Program

Description	2023-2024 Actual Revenue	2024-2025 Actual Revenue	2025-2026 Adopted Budget	2025-2026 Actual Revenue To Date	Percent Received
Interest Income	22,969	11,798	18,350	22,217	121%
Reserves	-	-	7,025	-	-
Intergovernmental	1,026,255	1,035,885	1,050,000	1,050,000	100%
Total Revenue	\$1,049,224	\$1,047,683	\$1,075,375	\$1,072,217	100%

Description	2023-2024 Actual Expenditures	2024-2025 Actual Expenditures	2025-2026 Adopted Budget	2025-2026 Expenditures to Date	Percent Spent
Salaries and Wages	446,978	450,616	446,252	265,583	60%
Benefits	110,487	111,182	113,348	65,451	58%
Supplies and Other Charges	105,586	162,312	-	9,160	-
Contingency	-	-	508,750	-	-
Repairs and Maintenance	40,000	-	-	-	-
Contractual Services	-	12,574	-	-	-
Capital Outlay	346,174	310,999	7,025	18,885	269%
Total Expense	\$1,049,224	\$1,047,683	\$1,075,375	\$359,079	33%

**Brazos County, Texas
 FY 2025-2026 Budget to Actuals -
 Revenue and Expenditure
 Categories Report by Fund
 (Unaudited)**

Fund: 33000 Sheriff's Office Crime Fund

Description	2023-2024 Actual Revenue	2024-2025 Actual Revenue	2025-2026 Adopted Budget	2025-2026 Actual Revenue To Date	Percent Received
Interest Income	4,597	4,104	3,150	1,928	61%
Other Revenue	60	-	-	-	-
Reserves	-	-	117,815	-	-
Total Revenue	\$4,657	\$4,104	\$120,965	\$1,928	2%

Description	2023-2024 Actual Expenditures	2024-2025 Actual Expenditures	2025-2026 Adopted Budget	2025-2026 Expenditures to Date	Percent Spent
Supplies and Other Charges	3,237	1,397	63,100	3,542	6%
Contingency	-	-	23,865	-	-
Repairs and Maintenance	-	-	4,000	-	-
Contractual Services	-	-	-	1,910	-
Capital Outlay	-	-	30,000	-	-
Total Expense	\$3,237	\$1,397	\$120,965	\$5,452	5%

Brazos County, Texas
FY 2025-2026 Budget to Actuals -
Revenue and Expenditure
Categories Report by Fund
(Unaudited)

Fund: 34000 District Attorney Crime
Fund

Description	2023-2024 Actual Revenue	2024-2025 Actual Revenue	2025-2026 Adopted Budget	2025-2026 Actual Revenue To Date	Percent Received
Charges for Services	11,242	45,351	20,000	22,790	114%
Interest Income	12,302	9,256	7,700	3,155	41%
Reserves	-	-	126,005	-	-
Total Revenue	\$23,544	\$54,607	\$153,705	\$25,946	17%

Description	2023-2024 Actual Expenditures	2024-2025 Actual Expenditures	2025-2026 Adopted Budget	2025-2026 Expenditures to Date	Percent Spent
Salaries and Wages	27,105	69,806	88,179	21,126	24%
Benefits	10,539	35,555	40,346	10,359	26%
Supplies and Other Charges	18,986	22,905	24,180	7,277	30%
Contractual Services	360	360	1,000	180	18%
Other Financing Uses	9,000	-	-	-	-
Total Expense	\$65,990	\$128,625	\$153,705	\$38,942	25%

Brazos County, Texas
FY 2025-2026 Budget to Actuals -
Revenue and Expenditure
Categories Report by Fund
(Unaudited)

Fund: 35000 Election Contracts Fund

Description	2023-2024 Actual Revenue	2024-2025 Actual Revenue	2025-2026 Adopted Budget	2025-2026 Actual Revenue To Date	Percent Received
Charges for Services	14,088	11,368	25,000	7,051	28%
Interest Income	3,591	2,140	1,925	367	19%
Reserves	-	-	30,316	-	-
Total Revenue	\$17,679	\$13,508	\$57,241	\$7,419	13%

Description	2023-2024 Actual Expenditures	2024-2025 Actual Expenditures	2025-2026 Adopted Budget	2025-2026 Expenditures to Date	Percent Spent
Supplies and Other Charges	7,163	10,483	11,700	5,646	48%
Repairs and Maintenance	5,620	6,400	25,041	-	-
Contractual Services	14,166	27,166	20,500	18,753	91%
Total Expense	\$26,949	\$44,048	\$57,241	\$24,399	43%

**Brazos County, Texas
 FY 2025-2026 Budget to Actuals -
 Revenue and Expenditure
 Categories Report by Fund
 (Unaudited)**

Fund: 39010 Brazos County Housing
 Finance Corporation

Description	2023-2024 Actual Revenue	2024-2025 Actual Revenue	2025-2026 Adopted Budget	2025-2026 Actual Revenue To Date	Percent Received
Charges for Services	5,334	-	5,000	79,769	1,595%
Interest Income	27,592	28,159	-	15,480	-
Reserves	-	-	587,698	-	-
Total Revenue	\$32,926	\$28,159	\$592,698	\$95,249	16%

Description	2023-2024 Actual Expenditures	2024-2025 Actual Expenditures	2025-2026 Adopted Budget	2025-2026 Expenditures to Date
Supplies and Other Charges	174	-	4,735	-
Contingency	-	-	483,698	-
Professional Services	-	13,000	104,265	-
Total Expense	\$174	\$13,000	\$592,698	-

Brazos County, Texas
FY 2025-2026 Budget to Actuals -
Revenue and Expenditure
Categories Report by Fund
(Unaudited)

Fund: 93000 Regional Mobility Authority

Description	2023-2024 Actual Revenue	2024-2025 Actual Revenue	2025-2026 Adopted Budget	2025-2026 Actual Revenue To Date	Percent Received
Interest Income	497	2,220	500	1,143	229%
Other Revenue	30,000	10,000	-	-	-
Reserves	-	-	31,414	-	-
Total Revenue	\$30,497	\$12,220	\$31,914	\$1,143	4%

Description	2023-2024 Actual Expenditures	2024-2025 Actual Expenditures	2025-2026 Adopted Budget	2025-2026 Expenditures to Date	Percent Spent
Contingency	-	-	26,914	-	-
Professional Services	7,500	3,744	5,000	2,950	59%
Total Expense	\$7,500	\$3,744	\$31,914	\$2,950	9%

Brazos County, Texas
FY 2025-2026 Budget to Actuals -
Revenue and Expenditure
Categories Report by Fund
(Unaudited)

Fund: 41000 General Obligation Debt
 Service Fund

Description	2023-2024 Actual Revenue	2024-2025 Actual Revenue	2025-2026 Adopted Budget	2025-2026 Actual Revenue To Date	Percent Received
Taxes	11,772,533	11,384,097	8,998,260	9,120,136	101%
Interest Income	541,787	523,248	355,000	250,113	70%
Reserves	-	-	2,418,672	-	-
Other Financing Sources	1,250,000	1,250,000	1,250,000	1,250,000	100%
Total Revenue	\$13,564,320	\$13,157,345	\$13,021,932	\$10,620,249	82%

Description	2023-2024 Actual Expenditures	2024-2025 Actual Expenditures	2025-2026 Adopted Budget	2025-2026 Expenditures to Date	Percent Spent
Debt Service	11,864,575	11,795,609	13,021,932	1,600,066	12%
Total Expense	\$11,864,575	\$11,795,609	\$13,021,932	\$1,600,066	12%

Brazos County, Texas
FY 2025-2026 Budget to Actuals -
Revenue and Expenditure
Categories Report by Fund
(Unaudited)

Fund: 43200 2020 Certificates of
Obligation

Description	2023-2024 Actual Revenue	2024-2025 Actual Revenue	2025-2026 Adopted Budget	2025-2026 Actual Revenue To Date	Percent Received
Interest Income	411,956	199,315	-	28,853	-
Other Revenue	-	949	-	-	-
Reserves	-	-	1,023,030	-	-
Other Financing Sources	-	777,473	731,729	-	-
Total Revenue	\$411,956	\$977,737	\$1,754,759	\$28,853	2%

Description	2023-2024 Actual Expenditures	2024-2025 Actual Expenditures	2025-2026 Adopted Budget	2025-2026 Expenditures to Date	Percent Spent
Supplies and Other Charges	0	480,657	-	-	-
Contractual Services	2,398,009	-	-	-	-
Capital Outlay	632,060	4,672,335	1,754,759	1,232,948	70%
Total Expense	\$3,030,069	\$5,152,992	\$1,754,759	\$1,232,948	70%

Brazos County, Texas
FY 2025-2026 Budget to Actuals -
Revenue and Expenditure
Categories Report by Fund
(Unaudited)

Fund: 43230 On System Road Bond -
TXDOT

Description	2023-2024 Actual Revenue	2024-2025 Actual Revenue	2025-2026 Adopted Budget	2025-2026 Actual Revenue To Date	Percent Received
Interest Income	1,070,010	629,337	343,500	257,986	75%
Reserves	-	-	11,356,929	-	-
Total Revenue	\$1,070,010	\$629,337	\$11,700,429	\$257,986	2%

Description	2023-2024 Actual Expenditures	2024-2025 Actual Expenditures	2025-2026 Adopted Budget	2025-2026 Expenditures to Date	Percent Spent
Contractual Services	5,741,125	5,821,208	11,700,429	10,266,170	88%
Total Expense	\$5,741,125	\$5,821,208	\$11,700,429	\$10,266,170	88%

**Brazos County, Texas
 FY 2025-2026 Budget to Actuals -
 Revenue and Expenditure
 Categories Report by Fund
 (Unaudited)**

Fund: 43231 Off System Road Bond

Description	2023-2024 Actual Revenue	2024-2025 Actual Revenue	2025-2026 Adopted Budget	2025-2026 Actual Revenue To Date	Percent Received
Interest Income	500,363	276,233	158,000	101,754	64%
Reserves	-	-	5,053,031	-	-
Total Revenue	\$500,363	\$276,233	\$5,211,031	\$101,754	2%

Description	2023-2024 Actual Expenditures	2024-2025 Actual Expenditures	2025-2026 Adopted Budget	2025-2026 Expenditures to Date	Percent Spent
Capital Outlay	3,929,511	2,056,242	5,211,031	3,857,745	74%
Total Expense	\$3,929,511	\$2,056,242	\$5,211,031	\$3,857,745	74%

Brazos County, Texas
FY 2025-2026 Budget to Actuals -
Revenue and Expenditure
Categories Report by Fund
(Unaudited)

Fund: 43232 2023 Certificates of
Obligation

Description	2023-2024 Actual Revenue	2024-2025 Actual Revenue	2025-2026 Adopted Budget	2025-2026 Actual Revenue To Date	Percent Received
Interest Income	561,066	483,091	377,000	199,423	53%
Reserves	-	-	9,060,487	-	-
Other Financing Sources	-	-	60,040,000	59,000,000	98%
Total Revenue	\$561,066	\$483,091	\$69,477,487	\$59,199,423	85%

Description	2023-2024 Actual Expenditures	2024-2025 Actual Expenditures	2025-2026 Adopted Budget	2025-2026 Expenditures to Date	Percent Spent
Capital Outlay	98,459	2,538,351	69,477,487	3,906,973	6%
Other Financing Uses	-	-	-	4,896,686	-
Total Expense	\$98,459	\$2,538,351	\$69,477,487	\$8,803,659	13%

Brazos County, Texas
FY 2025-2026 Budget to Actuals -
Revenue and Expenditure
Categories Report by Fund
(Unaudited)

Fund: 45000 Capital Improvement Fund

Description	2023-2024 Actual Revenue	2024-2025 Actual Revenue	2025-2026 Adopted Budget	2025-2026 Actual Revenue To Date
Other Revenue	(37,500)	34,000	-	-
Reserves	0	-	13,707,738	-
Other Financing Sources	4,180,663	764,118	14,226,237	-
Total Revenue	\$4,143,163	\$798,118	\$27,933,975	-

Description	2023-2024 Actual Expenditures	2024-2025 Actual Expenditures	2025-2026 Adopted Budget	2025-2026 Expenditures to Date	Percent Spent
Contingency	-	-	2,000,000	-	-
Capital Outlay	9,905,434	4,871,429	25,933,975	5,030,774	19%
Total Expense	\$9,905,434	\$4,871,429	\$27,933,975	\$5,030,774	18%

Brazos County, Texas
FY 2025-2026 Budget to Actuals -
Revenue and Expenditure
Categories Report by Fund
(Unaudited)

Fund: 50000 Health and Life Insurance
Fund

Description	2023-2024 Actual Revenue	2024-2025 Actual Revenue	2025-2026 Adopted Budget	2025-2026 Actual Revenue To Date	Percent Received
Other Revenue	27,567,563	25,008,902	24,054,960	17,634,395	73%
Reserves	-	-	10,179,719	-	-
Total Revenue	\$27,567,563	\$25,008,902	\$34,234,679	\$17,634,395	52%

Description	2023-2024 Actual Expenditures	2024-2025 Actual Expenditures	2025-2026 Adopted Budget	2025-2026 Expenditures to Date	Percent Spent
Salaries and Wages	221,846	249,178	642,530	166,789	26%
Benefits	106,496	127,533	263,242	82,369	31%
Supplies and Other Charges	58,937	66,752	107,730	30,978	29%
Contingency	-	-	2,750,927	-	-
Repairs and Maintenance	65	120	750	240	32%
Contractual Services	23,176,197	25,285,310	30,034,500	17,694,972	59%
Professional Services	372,198	386,387	435,000	270,361	62%
Total Expense	\$23,935,739	\$26,115,280	\$34,234,679	\$18,245,709	53%

**Brazos County, Texas
 FY 2025-2026 Contingency
 Budget to Actuals by Fund
 (Unaudited)**

Fund: 01000 General Fund - Contingency

Department	2025-2026 Adopted Budget	2025-2026 Contingency	2025-2026 Remaining to Date
Pre-Trial Bond Supervision Contingency - 10003000 *	10,000.00	-	10,000.00
Commissioner's Court Contingency - 11001500	6,500,000.00	3,777,857.64	10,277,857.64
District Attorney - Child Protective Services Contingency - 19010000 *	1,900.00	-	1,900.00
Vital Statistics/Preservation - 21010000 *	5,000.00	-	5,000.00
County Specialty Court Program Contingency - 22700100 *	20,000.00	-	20,000.00
Court Facility - Administration - 54001410 *	41,815.00	(15,525.00)	26,290.00
Total General Fund Contingency	6,578,715.00	3,762,332.64	10,341,047.64

* Can only be used for that program or division

**Brazos County, Texas
 FY 2025-2026 Contingency
 Budget to Actuals by Fund
 (Unaudited)**

Fund: 11000 HOT Fund - Contingency *

Department	2025-2026 Adopted Budget	2025-2026 Contingency	2025-2026 Remaining to Date
HOT Fund Contingency - 11002500	500,000.00	(23,500.00)	476,500.00
Total HOT Fund Contingency	500,000.00	(23,500.00)	476,500.00

* Can only be used for this fund

**Brazos County, Texas
 FY 2025-2026 Contingency
 Budget to Actuals by Fund
 (Unaudited)**

Fund: 13000 Unclaimed Property Fund - Contingency *

Department	2025-2026 Adopted Budget	2025-2026 Contingency	2025-2026 Remaining to Date
Contingency - 12005000	144,897.00	-	144,897.00
Total Unclaimed Property Fund Contingency	144,897.00	-	144,897.00

* Can only be used for this fund

**Brazos County, Texas
 FY 2025-2026 Contingency
 Budget to Actuals by Fund
 (Unaudited)**

Fund: 20000 County Clerk Records Management Fund - Contingency *

Department	2025-2026 Adopted Budget	2025-2026 Contingency	2025-2026 Remaining to Date
Contingency - 21005000	1,056,168.00	(1,000.00)	1,055,168.00
Total Count Clerk Records Management Fund Contingency	1,056,168.00	(1,000.00)	1,055,168.00

* Can only be used for this fund

**Brazos County, Texas
 FY 2025-2026 Contingency
 Budget to Actuals by Fund
 (Unaudited)**

Fund: 20010 County Clerk Archival Fund - Contingency *

Department	2025-2026 Adopted Budget	2025-2026 Contingency	2025-2026 Remaining to Date
Contingency - 21006000	1,541,000.00	-	1,541,000.00
Total Count Clerk Archival Fund Contingency	1,541,000.00	-	1,541,000.00

* Can only be used for this fund

**Brazos County, Texas
 FY 2025-2026 Contingency
 Budget to Actuals by Fund
 (Unaudited)**

Fund: 22000 Courthouse Security Fund - Contingency *

Department	2025-2026 Adopted Budget	2025-2026 Contingency	2025-2026 Remaining to Date
Contingency - 51000100	300,702.00	(4,400.00)	296,302.00
Total Courthouse Security Fund Contingency	300,702.00	(4,400.00)	296,302.00

* Can only be used for this fund

**Brazos County, Texas
 FY 2025-2026 Contingency
 Budget to Actuals by Fund
 (Unaudited)**

Fund: 24000 Justice of the Peace Technology Fund - Contingency *

Department	2025-2026 Adopted Budget	2025-2026 Contingency	2025-2026 Remaining to Date
JP Technology Administration - 24005000	73,738.00	-	73,738.00
Total Justice of the Peace Technology Fund Contingency	73,738.00	-	73,738.00

* Can only be used for this fund and specific divisions

**Brazos County, Texas
 FY 2025-2026 Contingency
 Budget to Actuals by Fund
 (Unaudited)**

Fund: 25000 Forfeiture Fund - Contingency *

Department	2025-2026 Adopted Budget	2025-2026 Contingency	2025-2026 Remaining to Date
Sheriff Forfeiture Fund - 2801000	16,652.00	-	16,652.00
Total Forfeiture Fund Contingency	16,652.00	-	16,652.00

* Can only be used for this fund

**Brazos County, Texas
 FY 2025-2026 Contingency
 Budget to Actuals by Fund
 (Unaudited)**

Fund: 26000 District Attorney Hot Check Collections Fund - Contingency *

Department	2025-2026 Adopted Budget	2025-2026 Contingency	2025-2026 Remaining to Date
Contingency - 19006000	6,285.00	-	6,285.00
Total District Attorney Hot Check Collections Fund - Contingency	6,285.00	-	6,285.00

* Can only be used for this fund

**Brazos County, Texas
 FY 2025-2026 Contingency
 Budget to Actuals by Fund
 (Unaudited)**

Fund: 27000 Bail Bond Board Fund - Contingency *

Department	2025-2026 Adopted Budget	2025-2026 Contingency	2025-2026 Remaining to Date
Contingency - 12006000	117,164.00	-	117,164.00
Total Bail Bond Board Fund - Contingency	117,164.00	-	117,164.00

* Can only be used for this fund

**Brazos County, Texas
 FY 2025-2026 Contingency
 Budget to Actuals by Fund
 (Unaudited)**

Fund: 29000 Vehicle Inventory Interest Fund - Contingency *

Department	2025-2026 Adopted Budget	2025-2026 Contingency	2025-2026 Remaining to Date
Contingency - 13006000	427,633.00	-	427,633.00
Total Vehicle Inventory Interest Fund - Contingency	427,633.00	-	427,633.00

* Can only be used for this fund

**Brazos County, Texas
 FY 2025-2026 Contingency
 Budget to Actuals by Fund
 (Unaudited)**

Fund: 30000 Grant Fund - Contingency *

Department	2025-2026 Adopted Budget	2025-2026 Contingency	2025-2026 Remaining to Date
Metropolitan Planning - 424100	12,329.00	(3,000.00)	9,329.00
Total Grant Fund Contingency	12,329.00	(3,000.00)	9,329.00

* Can only be used for this fund and specific divisions

**Brazos County, Texas
 FY 2025-2026 Contingency
 Budget to Actuals by Fund
 (Unaudited)**

**Fund: 32000 SB 22 2023 Rural Law Enforcement Salary Assistance Program -
 Contingency ***

Department	2025-2026 Adopted Budget	2025-2026 Contingency	2025-2026 Remaining to Date
Sheriff's Office - Rural Law Enforcement Grant Program - 281002	508,750.00	(469,833.38)	38,916.62
Total SB 22 2023 Rural Law Enforcement Salary Assistance Program Fund Contingency	508,750.00	(469,833.38)	38,916.62

* Can only be used for this fund and specific divisions

**Brazos County, Texas
 FY 2025-2026 Contingency
 Budget to Actuals by Fund
 (Unaudited)**

Fund: 33000 Sheriff's Office Crime Fund - Contingency *

Department	2025-2026 Adopted Budget	2025-2026 Contingency	2025-2026 Remaining to Date
Contingency - 28050000	23,865.00	(1,910.00)	21,955.00
Total Sheriff's Office Crime Fund Contingency	23,865.00	(1,910.00)	21,955.00

* Can only be used for this fund

**Brazos County, Texas
 FY 2025-2026 Contingency
 Budget to Actuals by Fund
 (Unaudited)**

Fund: 45000 General Permanent Improvement Fund - Contingency *

Department	2025-2026 Adopted Budget	2025-2026 Contingency	2025-2026 Remaining to Date
Commissioner's Court Contingency - 63110001	2,000,000.00	(427,745.78)	1,572,254.22
Total General Permanent Improvement Fund Contingency	2,000,000.00	(427,745.78)	1,572,254.22

* Can only be used for this fund

**Brazos County, Texas
 FY 2025-2026 Contingency
 Budget to Actuals by Fund
 (Unaudited)**

Fund: 50000 Health and Life Insurance Fund - Contingency *

Department	2025-2026 Adopted Budget	2025-2026 Contingency	2025-2026 Remaining to Date
Group Insurance - Administration - 64005000	2,730,927.00	-	2,730,927.00
Health and Wellness Clinic - 64005100	20,000.00	-	20,000.00
Total Health and Life Insurance Fund Contingency	2,750,927.00	-	2,750,927.00

* Can only be used for this fund

**Brazos County, Texas
 FY 2025-2026 Contingency
 Budget to Actuals by Fund
 (Unaudited)**

Fund: 55000 Jail Commissary Fund - Contingency *

Department	2025-2026 Adopted Budget	2025-2026 Contingency	2025-2026 Remaining to Date
Jail Commissary - 28006000	387,089.00	-	387,089.00
Total Jail Commissary Fund Contingency	387,089.00	-	387,089.00

* Can only be used for this fund

**Brazos County, Texas
 FY 2025-2026 Contingency
 Budget to Actuals by Fund
 (Unaudited)**

Fund: 58000 County Attorney Operating Fund - Contingency *

Department	2025-2026 Adopted Budget	2025-2026 Contingency	2025-2026 Remaining to Date
Contingency - 18006000	66,359.00	-	66,359.00
Total County Attorney Operating Fund Contingency	66,359.00	-	66,359.00

* Can only be used for this fund



**BRAZOS COUNTY
BRYAN, TEXAS**

DEPARTMENT:

NUMBER:

DATE OF COURT MEETING: 6/23/2026

ITEM: Acknowledgement of Monthly Reports submitted in June 2026.

TO: Commissioners Court

DATE: 02/04/2026

FISCAL IMPACT: False

BUDGETED: False

DOLLAR AMOUNT: \$0.00

ATTACHMENTS:

File Name

Description

Type

2026-06-15 Monthly Reports Submitted in June 2026.pdf	Monthly Reports submitted in June 2026	Cover Memo
---	--	------------

**MONTHLY REPORT RECAPITULATION
CONSTABLE J.P. INGRAM - PRECINCT 3**

May-26

RECEIPTS:

Fees Received _____ \$555.00

Execution Judgements:

Constable fees / Expenses _____
 Constable Commissions _____
 Due to Attorneys _____
 Other _____ \$555.00

Other _____

Beginning Balance _____
 Cash On Hand _____

GRAND TOTAL OF RECEIPTS _____ \$555.00

DISBURSEMENTS:

Remitted to Treasurer
 Constable Fees _____
 Executions / Judgements _____
 Other _____ \$555.00

Ending Balance _____
 Cash on Hand _____

GRAND TOTAL DISBURSEMENTS _____ \$555.00

Type	106 #of	
ATTORNEY GENERAL	8	6
CITATION	3	6
EVICCTIONS	76	65
SUMMONS	1	1
WRIT OF GARNISHMENT		
WRIT OF EXECUTION	1	0
WRIT OF POSSESSION	16	10
TAX SUITS		
CIVIL SUBPOENA		
NOTICE OF PROTECTIVE ORDER		
NOTICE OF HEARING		
REPAIR AND REMEDY	1	1

Prepared By: Angie Regmund

Approved BY: J.P. Ingram
 CONSTABLE J.P. INGRAM PCT. 3

Civil Paper Statistics

TXBRAZOSPROD

Date Range: 05/01/2026 - 05/31/2026

Locations: Constable 3

Overall Statistics	
Papers Issued	106
Papers Served	90
Papers Unserved or Active	18
Papers Returned	8
Papers Inactive	6
Papers Expired	4

Paper Statistics						
	Issued	Served	Unserved or Active	Returned	Inactive	Expired
Attorney General Billed Paper	8	6	2	2	0	0
Citation	3	6	0	2	0	0
Citation by Publication	0	0	0	0	0	0
Civil Subpoena	0	0	0	0	0	0
Criminal Subpoena	0	0	0	0	0	0
Eviction Citation	0	0	0	0	0	0
Forcible Detainer	76	65	10	0	11	4
Issue Order of Sale	0	0	0	0	0	0
Issue Writ of Possession	0	0	0	0	0	0
Notice	0	0	0	0	0	0
Notice of Application of Protective Order	0	0	0	0	0	0
Notice of Hearing	0	0	0	0	0	0
Precept to Serve	0	0	0	0	0	0
Protective Order	0	0	0	0	0	0
Repair and Remedy	1	1	0	0	0	0
Show Cause	0	0	0	0	0	0
Small Claims	0	0	0	0	0	0
Subpoena	0	0	0	0	0	0
Summons	1	2	0	0	0	0
Tax Suit	0	0	0	0	0	0
Tax Warrant	0	0	0	0	0	0
Temporary Protective Order	0	0	0	0	0	0

Civil Paper Statistics

TXBRAZOSPROD

Date Range: 05/01/2026 - 05/31/2026

Locations: Constable 3

Paper Statistics	Issued	Served	Unserved or Active	Returned	Inactive	Expired
Truancy Check	0	0	0	0	0	0
Turnover Order	0	0	0	0	0	0
Warrant	0	0	0	0	0	0
Writ of Attachment	0	0	0	0	0	0
Writ of Execution	0	0	0	0	0	0
Writ of Execution	1	0	0	3	0	0
Writ of Garnishment	0	0	0	0	0	0
Writ of Garnishment	0	0	0	0	0	0
Writ of Habeas Corpus	0	0	0	0	0	0
Writ of Injunction	0	0	0	0	0	0
Writ of Possession	16	10	3	1	5	0
Writ of Reentry	0	0	0	0	0	0
Writ of Sequestration	0	0	1	0	0	0

Officer Statistics	Assigned	Services	Attempts	Expired
Coleman, Thomas	0	0	0	0
COLEMAN, THOMAS	0	0	0	0
COLEMAN, THOMAS	0	0	0	0
Corwin, Richard	97	79	55	4
Citation	5	6	15	0
Forcible Detainer	76	62	40	4
Repair and Remedy	1	1	0	0
Writ of Possession	15	10	0	0
Drake, Andrew T.	0	0	0	0
FRALEY, SCOTT	0	0	0	0
Giordano, Christopher	11	8	10	0
Attorney General Billed Paper	11	6	7	0
Forcible Detainer	0	2	3	0
Glidewell, Pete	0	0	0	0

Civil Paper Statistics

TXBRAZOSPROD

Date Range: 05/01/2026 - 05/31/2026

Locations: Constable 3

Officer Statistics	Assigned	Services	Attempts	Expired
INGRAM, J.P.	0	0	0	0
INGRAM, J.P.	0	0	0	0
Ingram, J.P.	0	0	0	0
INGRAM, JP	0	0	0	0
INGRAM, JP	0	0	0	0
Ingram, JP	0	0	0	0
Jones, Kimberley	1	2	0	0
Summons	1	2	0	0
Lively, Calder	2	1	0	0
Forcible Detainer	0	1	0	0
Writ of Execution	1	0	0	0
Writ of Sequestration	1	0	0	0
MATEJKA, JOE	0	0	0	0
McDermott, Chris	0	0	0	0
Poe, Ryan	0	0	0	0
SEVERN, DAN	0	0	0	0
Smith, Glenda	0	0	0	0
White, Chris	0	0	0	0

**BRAZOS COUNTY
MONTHLY REPORT RECAPITULATION
CONSTABLE HEZEKIAH CARTER, JR. - PRECINCT 4
FOR THE MONTH OF MAY, 2026**

Fees Received		<u>\$340.00</u>
Execution Judgements:		
Constable fees / Expenses		
Constable Commissions		
Due to Attorneys		
Other		
Other		
Beginning Balance		
Cash On Hand		
GRAND TOTAL OF RECEIPTS		<u>\$340.00</u>
DISBURSEMENTS:		
Remitted to Treasurer		
Constable Fees	<u>\$340.00</u>	
Executions / Judgements		
Other		<u>\$340.00</u>
Ending Balance		
Cash on Hand		
GRAND TOTAL DISBURSEMENTS		<u>\$340.00</u>

Papers Served:	
Type	#of
Citations	3
Show Cause	1

Prepared By:
Kimberly Harris

Approved BY:

Constable Hezekiah Carter, Jr.-Precinct 4

**BRAZOS COUNTY CLERK
MONTHLY REPORT RECAPITULATION
FOR THE MONTH OF
May 2026**

ODYSSEY			Total Daily Deposit							KOFILE													
Date	Chase Closed Batch Report	Odyssey (Efile)	Cash	(CC) POS	Checks/MO	Deposit	Hot Ck Fee	Cash	Checks/ MO	Direct Deposit & IRS	POS	CSC	EPN	SMP/ Erx	Escrow Draws	Permitium Draws	Escrow Pay	Charged	A/R pymt	Void	Trust Deposit	Total Kofile	
5/1/2026	1,084.00	1,084.00				833.30		570.00	263.30		978.00	2,249.00	394.00	5,394.00	14.00	100.00					6,300.00	16,262.30	
5/2/2026																							
5/3/2026																							
5/4/2026	888.00	888.00				1,601.00		531.00	1,070.00		929.00	1,565.00	686.00	5,368.00	15.20	102.00		272.00	462.00	7.00		10,069.20	
5/5/2026	403.00	403.00				547.00		301.00	246.00	270.00	1,330.00	1,859.00	281.00	3,080.00	59.00	65.00		155.00				7,646.00	
5/6/2026	1,516.00	1,516.00				811.16		665.00	146.16		1,188.00	598.00	311.00	2,576.00								5,428.00	10,912.16
5/7/2026	809.00	809.00				1,243.00		209.00	1,034.00	90.00	894.00	2,024.00	524.00	2,414.00	4.00	90.00	105.00		49.00			2,472.00	9,601.00
5/8/2026	32.00	32.00		12.00		297.51		56.00	241.51		1,908.00	676.00	33.00	3,471.00	8.00	111.00		328.00				500.00	7,332.51
5/9/2026																							
5/10/2026																							
5/11/2026	920.00	920.00				872.00		194.00	678.00	150.00	1,249.00	1,415.00	375.00	2,974.00	13.00	86.00					122.00	431,120.00	438,132.00
5/12/2026	954.00	954.00				423.00		176.00	247.00		1,334.00	1,063.00	412.00	4,966.00	60.00	125.00		137.00				695.00	9,215.00
5/13/2026	45.00	45.00				2,274.78		71.00	2,203.78		1,855.00	1,150.00	148.00	2,643.00	35.00	180.00		97.00	1,900.00				6,482.78
5/14/2026	305.00	305.00		12.00		218.80		62.80	156.00		586.20	1,138.00	33.00	3,262.00	175.00	193.00		72.00					5,678.00
5/15/2026	538.00	538.00				611.00		451.00	160.00		895.00	1,448.00	364.25	5,427.00	68.00	86.00							8,899.25
5/16/2026																							
5/17/2026																							
5/18/2026	1,098.00	1,098.00				1,221.00		436.00	785.00	210.00	988.00	1,000.00	855.00	3,763.00		176.00		121.00	209.00			25,500.00	33,625.00
5/19/2026	584.00	584.00				1,774.83		37.00	1,737.83	30.00	747.00	660.00	173.00	4,415.00	239.23	63.00		144.00			134.23	634.23	8,746.06
5/20/2026	780.00	780.00	12.00			654.00		255.00	387.00		1,183.00	2,026.00	305.00	3,584.00	334.00	167.00		120.00					8,361.00
5/21/2026	617.00	617.00				350.00		138.00	212.00		1,229.00	1,358.00	494.00	3,218.00	35.00	23.00						500.00	7,207.00
5/22/2026	490.00	490.00				142.00		109.00	33.00		869.00	1,392.00	111.00	1,818.00	20.00	67.00		328.00					4,747.00
5/23/2026																							
5/24/2026																							
5/25/2026																							
5/26/2026	744.00	744.00				2,127.00		491.00	1,636.00	60.00	1,341.00	2,822.25	968.00	5,741.00	14.00	456.00							12,944.25
5/27/2026	640.00	640.00				543.00		364.00	179.00		765.00	1,710.00	730.00	5,886.00		226.00		72.00		8.00			9,924.00
5/28/2026	1,379.00	1,379.00			362.00	2,137.83		465.00	1,310.83		800.00	2,465.00	103.00	5,223.00	53.50	147.00						500.00	11,067.33
5/29/2026	504.00	504.00				781.00		180.00	601.00	30.00	909.00	2,032.00	548.00	6,268.00	42.00	92.00		197.00					10,899.00
5/30/2026																							
5/31/2026																							
TOTAL	14,330.00	14,330.00	12.00	24.00	362.00	19,463.21		5,761.80	13,327.41	840.00	21,977.20	30,650.25	7,848.25	81,491.00	1,188.93	2,555.00	105.00	2,043.00	3,327.00	149.23	473,649.23	637,750.84	

TOTAL REPORT, ODYSSEY	14,728.00	14,728.00
REPORT KOFILE	637,750.84	637,750.84
GRAND TOTAL	652,478.84	

Total Fees (Revenue)	
Diff.	
Diff.	

Karen McQueen
KAREN MCQUEEN, COUNTY CLERK

Ashlie Peters-Bowman
ASHLIE PETERS-BOWMAN, CHIEF DEPUTY

6/2/26
DATE



**Director of Collections
Tanya Skinner
300 East 26th Street, Ste 1401
Bryan, Texas 77803
979-361-4297**

June 1, 2026

Brazos County Judge, Duane Peters
Commissioner Bentley Nettles, Pct1
Commissioner Chuck Konderla, Pct 2
Commissioner Fred Brown, Pct 3
Commissioner Wanda Watson, Pct 4

Re: May, 2026 reports for the fine and jury fees

Dear County Judge and County Commissioners,

Please find the attached monthly reports as required to report to the county commissioner's court at regular terms by the officer who collects fines, and judgements or jury fees.

1. GASB 34 is the fines assessed and collected during the prior month please see the following pages for the fines, pages 1-5.
2. Receipt journal by fund and fee code known as the jury fee collected with the style and number of the case in which each jury fee was collected and the name of the person whom the fees were collected from , pages 1-6.

Thank you for your time and consideration regarding this matter.

Sincerely yours,

Tanya Skinner
Director of Collections

GASB 34

TXBRAZOSPROD

Assessed: 05/01/2026 to 05/31/2026 Collected: 05/01/2026 to 05/31/2026 Case Categories: CR Case Types: ALL

Enterprise Case Manager County Clerk CCL #1 CCL #2 District Clerk 85th District Court 272nd District Court 361st District C

Criminal

Case #	Defendant	Disp Date		Assessed	Paid	Credits	Balance
18-05000-CRF-85	AUSTON, SEDRICK TREMAIN	05/22/2026	A	10,000.00	0.00	0.00	10,000.00
20-02669-CRM-CCL1	MACIAS, LEANNE ANGELICA	5/20/2026	A	500.00	0.00	0.00	500.00
21-03455-CRF-272	GARCIA, NELSON ARMANDO	5/12/2026	A	1,000.00	0.00	0.00	1,000.00
21-04587-CRF-361	Rodriguez, Samuel	5/13/2026	A	2,000.00	0.00	2,000.00	0.00
23-01513-CRM-CCL2	Garza, Cristobal	5/19/2026	A	1,000.00	0.00	0.00	1,000.00
23-02663-CRF-272	LAYTON, GARY DON	5/22/2026	A	1,000.00	0.00	0.00	1,000.00
24-00382-CRM-CCL1	LEVINE, ELISE MARIE	5/15/2026	A	500.00	0.00	500.00	0.00
24-01105-CRM-CCL2	OBRYANT, DANNETTE	5/28/2026	A	250.00	0.00	0.00	250.00
24-01827-CRF-361	GASTON, KENNETH LAMAR	5/20/2026	A	500.00	0.00	0.00	500.00
24-02121-CRF-272	WINSTON, PAMELA CONNORS	5/21/2026	A	500.00	0.00	0.00	500.00
24-02163-CRM-CCL1	LASHAY, CHRISTOPHER RAY, JR	5/11/2026	A	500.00	0.00	0.00	500.00
24-02845-CRM-CCL2	PUENTE, ANGEL LEE	5/4/2026	A	1,000.00	0.00	0.00	1,000.00
24-02957-CRM-CCL1	GARCIA-RIVERA, VICTOR	5/13/2026	A	750.00	0.00	0.00	750.00
25-00255-CRF-272	HENDERSON, HATAYSHIA QUANISHA	5/7/2026	A	500.00	0.00	0.00	500.00
25-00480-CRM-361	Sterling, Terran Levertis	5/15/2026	A	500.00	0.00	0.00	500.00
25-00694-CRM-CCL2	CARTER, BRANDY LEE	5/26/2026	A	500.00	0.00	0.00	500.00
25-00729-CRM-CCL1	ESPINOZA-SALAZAR, JESUS	5/13/2026	A	750.00	0.00	0.00	750.00
25-00760-CRM-CCL2	SALMERON MONTIEL, DAFNE ELIANET	5/5/2026	A	750.00	0.00	0.00	750.00
25-01054-CRF-85	AGUILAR-JUAREZ, ROLANDO ALEXANDER	5/27/2026	A	2,000.00	0.00	0.00	2,000.00
25-01105-CRF-85	HICKS, DALTON RAYMOND	5/12/2026	A	1,500.00	0.00	0.00	1,500.00
25-01478-CRF-85	LONG, ALEXANDER BLAKE	5/22/2026	A	900.00	0.00	0.00	900.00
25-01525-CRF-85	STINE, DAVID LEELAND	5/26/2026	A	1,000.00	0.00	0.00	1,000.00
25-01561-CRM-CCL1	VELA, CHELSEY MARIE	5/7/2026	A	1,000.00	0.00	0.00	1,000.00
25-01692-CRF-85	Ellis, Jeffery	5/26/2026	A	1,000.00	0.00	0.00	1,000.00
25-01720-CRF-361	MCKUIN, JAMES ROBERT	5/7/2026	A	500.00	0.00	0.00	500.00
25-01832-CRM-CCL1	MINKS, LUKE JAMES	5/27/2026	A	750.00	750.00	0.00	0.00
25-01886-CRM-CCL2	CANALITO, JENNIFER MARIE	5/26/2026	A	750.00	0.00	0.00	750.00
25-01922-CRM-CCL2	BRANDES, GRAYSON KYLE	5/19/2026	A	2,000.00	2,000.00	0.00	0.00

GASB 34

TXBRAZOSPROD

Assessed: 05/01/2026 to 05/31/2026 Collected: 05/01/2026 to 05/31/2026 Case Categories: CR Case Types: ALL

Enterprise Case Manager County Clerk CCL #1 CCL #2 District Clerk 85th District Court 272nd District Court 361st District C

Criminal

Case #	Defendant	Disp Date	Assessed	Paid	Credits	Balance
25-02014-CRM-CCL1	PONCE, FELIX ANTONIO MANUEL	5/18/2026 A	800.00	0.00	0.00	800.00
25-02058-CRM-CCL2	Marquez-Trejo, Wilfredo	5/28/2026	750.00	0.00	0.00	750.00
25-02063-CRM-CCL2	RODRIGUEZ, ABIGAIL JOY	5/7/2026 A	1,500.00	13.00	0.00	1,487.00
25-02112-CRM-CCL2	GARDNER, MARK DONTA	5/26/2026 A	500.00	500.00	0.00	0.00
25-02169-CRM-CCL2	ALEXANDER, DAYQUON KEVIN	5/7/2026 A	500.00	0.00	0.00	500.00
25-02185-CRM-CCL2	MADDEN, REBECCA LEE	5/21/2026 A	750.00	173.00	0.00	577.00
25-02244-CRM-CCL1	ALLEN, KEVEN MARKELL	5/18/2026 A	500.00	0.00	0.00	500.00
25-02265-CRM-CCL1	ORNELAS, IVAN ARMANDO	5/11/2026 A	500.00	0.00	0.00	500.00
25-02272-CRM-CCL1	WHITE, CECILEO EUGENE	5/13/2026 A	500.00	0.00	0.00	500.00
25-02275-CRM-CCL1	DUREN, JABARI DESHAWN	5/27/2026 A	500.00	0.00	0.00	500.00
25-02291-CRM-CCL1	BARKER, JUSTIN LEE	5/27/2026 A	1,000.00	1,000.00	0.00	0.00
25-02348-CRF-85	HROMCIK, LEIGH GARDINER	5/1/2026 A	500.00	0.00	0.00	500.00
25-02550-CRM-CCL2	WAGGONER, KEVIN PATRICK	5/6/2026 A	500.00	0.00	0.00	500.00
25-02605-CRM-CCL1	QUIRINO, JORGE DEMETRIO	5/18/2026 A	750.00	0.00	0.00	750.00
25-02664-CRM-CCL2	NORRIS, GABRIELLE FAY	5/13/2026 A	750.00	0.00	0.00	750.00
25-02702-CRM-CCL2	CANO, ERIC LYNN	5/7/2026 A	1,000.00	0.00	0.00	1,000.00
25-02775-CRF-85	MAJOR, KADARIUS JAVON	5/5/2026 A	500.00	0.00	0.00	500.00
25-02802-CRM-CCL1	TELLO, CHRISTOPHER	5/27/2026 A	1,000.00	0.00	0.00	1,000.00
25-02862-CRM-CCL1	Bankston, Parker	5/6/2026 A	500.00	500.00	0.00	0.00
25-02864-CRM-CCL2	BERRY, ALEXA KATHLEEN	5/26/2026 A	750.00	0.00	0.00	750.00
25-02874-CRM-CCL1	Edwards, Antwanisha Mesha	5/27/2026 A	750.00	0.00	0.00	750.00
25-02923-CRM-CCL1	BOTELLO, JESUS MARIA	5/20/2026 A	750.00	0.00	0.00	750.00
25-03071-CRM-CCL2	Tinnell, Caleb Bradley	5/13/2026 A	1,000.00	0.00	0.00	1,000.00
25-03175-CRM-CCL2	TOVAR LOPEZ, JUAN	5/13/2026 A	1,000.00	0.00	0.00	1,000.00
25-03184-CRM-CCL2	FOLSE, TRAVIS DEAN	5/5/2026 A	1,000.00	0.00	0.00	1,000.00
25-03263-CRM-CCL1	MINOR, EBONY RENEE	5/22/2026 A	500.00	0.00	0.00	500.00
25-03328-CRM-CCL2	Caesar, Mary Andrea	5/27/2026 A	500.00	0.00	0.00	500.00
25-03368-CRF-85	CURLEE, CLYDE LOVERN, JR	5/15/2026 A	500.00	0.00	0.00	500.00
25-03408-CRM-CCL1	TRUJILLO, DESI ALEXANDER	5/20/2026 A	500.00	0.00	0.00	500.00

GASB 34

TXBRAZOSPROD

Assessed: 05/01/2026 to 05/31/2026 Collected: 05/01/2026 to 05/31/2026 Case Categories: CR Case Types: ALL

Enterprise Case Manager County Clerk CCL #1 CCL #2 District Clerk 85th District Court 272nd District Court 361st District C

Criminal

Case #	Defendant	Disp Date		Assessed	Paid	Credits	Balance
25-03457-CRM-CCL2	BARRON, PAUL ANTHONY	5/26/2026	A	2,000.00	0.00	0.00	2,000.00
25-03550-CRM-CCL2	Bailey, Breyawna Rae Gale	5/26/2026		250.00	0.00	0.00	250.00
25-03609-CRF-85	MARTINEZ-DELEON, MARIO	5/26/2026	A	500.00	0.00	0.00	500.00
25-03643-CRM-CCL1	HAWKINS, EMMA ELIZABETH	5/18/2026	A	500.00	0.00	0.00	500.00
25-03725-CRM-CCL1	WILBORNE, JESSE LEE	5/20/2026	A	1,000.00	0.00	0.00	1,000.00
25-03744-CRF-85	ARREDONDO, FRANCISCO ARMANDO	5/5/2026	A	1,000.00	1,000.00	0.00	0.00
25-03746-CRF-361	BANKSTON, DAVID BROCK	5/22/2026	A	500.00	0.00	0.00	500.00
25-03766-CRF-361	Green, Cody Chance	5/28/2026	A	500.00	0.00	0.00	500.00
25-03775-CRF-85	Lewis, Tredarious	5/28/2026	A	800.00	0.00	0.00	800.00
25-03837-CRF-272	THURMAN, JARED BRIAN	5/15/2026	A	1,000.00	0.00	0.00	1,000.00
25-03868-CRM-CCL1	SALINAS, MATTHEW JAYDEN	5/11/2026	A	1,000.00	1,000.00	0.00	0.00
25-03871-CRM-CCL1	TINKER, LANDON DEAN	5/14/2026	A	750.00	750.00	0.00	0.00
25-03878-CRM-CCL2	TRUJILLO, ISAAH ANTHONY	5/27/2026	A	750.00	0.00	0.00	750.00
25-03880-CRM-CCL1	WARREN, DERIUS JEMARD	5/18/2026	A	500.00	0.00	0.00	500.00
25-03881-CRM-CCL2	THORNTON, JUSTIN MAURICE	5/5/2026	A	1,000.00	0.00	0.00	1,000.00
25-03887-CRM-CCL2	RIVERS, JAMES OTTIS	5/28/2026	A	250.00	0.00	0.00	250.00
25-03931-CRM-CCL1	BATES, KASON WYATT	5/20/2026	A	750.00	750.00	0.00	0.00
25-03994-CRF-361	DOOLEY, PATRICK JAMES	5/29/2026	A	500.00	0.00	0.00	500.00
25-04042-CRF-272	NUNEZ TOLEDANO, WALTER	5/22/2026	A	1,000.00	0.00	0.00	1,000.00
25-04083-CRM-CCL2	MORENO-CORPES, YADRIAN	5/19/2026	A	250.00	0.00	0.00	250.00
25-04099-CRM-CCL1	MINOR, KENNETH DEWAYNE	5/20/2026	A	500.00	0.00	0.00	500.00
25-04102-CRM-CCL2	TORRES, ZACHARY RYAN	5/21/2026	A	1,000.00	0.00	0.00	1,000.00
25-04108-CRM-CCL1	HUGUENARD, CARSON CHAMTON	5/11/2026	A	750.00	750.00	0.00	0.00
25-04133-CRM-CCL2	BELLOW, CORALEE RENEE	5/26/2026	A	750.00	0.00	0.00	750.00
25-04140-CRM-CCL2	DELAGARZA, ROY ANTHONY, JR	5/26/2026	A	500.00	0.00	0.00	500.00
25-04151-CRM-CCL2	MORALES, ZALEN JHASE	5/28/2026	A	500.00	0.00	0.00	500.00
25-04205-CRM-CCL1	PATLAN, ANTHONY MICHAEL	5/18/2026	A	750.00	0.00	0.00	750.00
25-04334-CRF-272	WYRICK, NALLELY	5/26/2026	A	500.00	0.00	0.00	500.00

GASB 34

TXBRAZOSPROD

Assessed: 05/01/2026 to 05/31/2026 Collected: 05/01/2026 to 05/31/2026 Case Categories: CR Case Types: ALL

Enterprise Case Manager County Clerk CCL #1 CCL #2 District Clerk 85th District Court 272nd District Court 361st District C

Criminal

Case #	Defendant	Disp Date		Assessed	Paid	Credits	Balance
25-04339-CRF-85	TELLEZ GRANADOS, CARLOS E	5/12/2026	A	750.00	0.00	0.00	750.00
25-04382-CRM-CCL2	ACARTO, ALFREDO MANUEL	5/21/2026		2,000.00	0.00	0.00	2,000.00
25-04563-CRM-CCL1	DUNKLE, MICHAEL ROBERT	5/20/2026	A	500.00	0.00	0.00	500.00
25-04566-CRM-CCL2	Anderson, Kayla Renee	5/12/2026	A	750.00	0.00	0.00	750.00
25-04576-CRM-CCL2	SMITH, VIRGINIA NICOLE	5/28/2026	A	1,000.00	0.00	0.00	1,000.00
25-04625-CRM-CCL1	ONEY, JOHN MASON	5/20/2026	A	750.00	750.00	0.00	0.00
25-04642-CRM-CCL2	PRATT, DONA RAY	5/13/2026	A	500.00	0.00	0.00	500.00
25-04643-CRF-85	BORAK, BARBARA KAYE	5/29/2026	A	1,000.00	0.00	0.00	1,000.00
25-04656-CRM-CCL1	DUPNICK, TYLER JACOB	5/27/2026	A	500.00	0.00	0.00	500.00
26-00296-CRM-CCL1	MORAN, AURORA SKYE	5/18/2026	A	1,000.00	0.00	0.00	1,000.00
26-00329-CRF-361	DOCKERY, JOHN RILEY	5/7/2026	A	500.00	500.00	0.00	0.00
26-00426-CRM-CCL1	BARAJAS, XIMENA	5/11/2026	A	750.00	0.00	0.00	750.00
26-00427-CRM-CCL2	BARRERA, CASEY LAVERN	5/7/2026	A	500.00	0.00	0.00	500.00
26-00431-CRM-CCL2	GLAY-WILLIAMS, JAHDEJAH DARICA	5/27/2026	A	350.00	0.00	0.00	350.00
26-00441-CRM-CCL2	JACOBS, SEAN MICHAEL	5/27/2026	A	800.00	0.00	0.00	800.00
26-00442-CRM-CCL2	KUDLOCK, CHARLENE ANDREA	5/7/2026	A	750.00	750.00	0.00	0.00
26-00455-CRM-CCL1	GARCIA, RANDY DIAZ	5/11/2026	A	100.00	0.00	0.00	100.00
26-00462-CRM-CCL1	Franklin, Stephanie	5/11/2026	A	600.00	0.00	0.00	600.00
26-00466-CRM-CCL1	FRIEDMAN, DANIKA KALIN	5/6/2026	A	100.00	100.00	0.00	0.00
26-00475-CRM-CCL2	HOFFMAN, MITCHELL KELLEN	5/19/2026	A	500.00	0.00	0.00	500.00
26-00522-CRM-CCL2	MARSHALL, JORDAN LANE	5/28/2026	A	750.00	0.00	0.00	750.00
26-00560-CRF-85	ROBINSON, PHILLIP	5/12/2026	A	500.00	500.00	0.00	0.00
26-00624-CRM-CCL2	JOHNSON, KATORI DESHELL	5/28/2026	A	500.00	0.00	0.00	500.00
26-00643-CRM-CCL2	Henry, David Miguel	5/28/2026	A	500.00	0.00	0.00	500.00
26-00692-CRM-CCL1	RAY, DONNA NICOLE	5/20/2026	A	250.00	0.00	0.00	250.00
26-00722-CRM-CCL2	Drake, Dallas Dwayne	5/28/2026	A	750.00	750.00	0.00	0.00
26-00774-CRM-CCL2	GAMBLE, DESMOND DESHON	5/14/2026	A	300.00	0.00	0.00	300.00
26-00825-CRM-CCL1	DALSING, JOHN CHRISTIAN	5/20/2026	A	750.00	0.00	0.00	750.00

GASB 34

TXBRAZOSPROD

Assessed: 05/01/2026 to 05/31/2026 Collected: 05/01/2026 to 05/31/2026 Case Categories: CR Case Types: ALL

Enterprise Case Manager County Clerk CCL #1 CCL #2 District Clerk 85th District Court 272nd District Court 361st District C
Criminal

Case #	Defendant	Disp Date		Assessed	Paid	Credits	Balance
26-00970-CRM-CCL2	PEARSON, TYLER DOUGLAS	5/26/2026	A	500.00	0.00	0.00	500.00
26-01028-CRM-CCL1	DE LA ROSA, STEVEN	5/13/2026		500.00	0.00	0.00	500.00
26-01110-CRM-CCL1	CARTAGENA, EDWIN JUNIOR	5/18/2026	A	500.00	0.00	0.00	500.00
26-01128-CRF-361	SWEED, TWYTANISHA TKEYEA PRECIOUS	5/14/2026	A	100.00	0.00	0.00	100.00
26-01133-CRM-CCL2	LEWIS, DE KOBE KEI MON	5/5/2026	A	500.00	0.00	0.00	500.00
26-01174-CRM-CCL1	MORALES, KAYLEE ANN	5/27/2026	A	500.00	0.00	0.00	500.00
26-01187-CRM-CCL2	SAUSEDA, BENITO DIAZE	5/5/2026	A	500.00	0.00	0.00	500.00
26-01218-CRM-CCL1	OGG, KENNETH CANTON	5/18/2026	A	200.00	0.00	0.00	200.00
26-01220-CRM-CCL1	HILL, MICHAEL JAMES	5/18/2026	A	200.00	0.00	0.00	200.00
26-01225-CRM-CCL1	BUSH, AVA RENEE	5/18/2026	A	750.00	0.00	0.00	750.00
26-01229-CRM-CCL2	MCMURRY, STANLEY BOYD	5/12/2026	A	750.00	0.00	0.00	750.00
26-01232-CRM-CCL1	GARZA, CORITA LYNN	5/18/2026	A	500.00	0.00	0.00	500.00
26-01257-CRM-CCL1	RATLIFF, EDDIE	5/13/2026	A	500.00	0.00	0.00	500.00
26-01261-CRM-CCL2	SEALS, JAHIM MALIK	5/12/2026	A	500.00	500.00	0.00	0.00
26-01353-CRM-CCL2	Apracio Cruz, Jose Efrain	5/26/2026	A	750.00	0.00	0.00	750.00
26-01422-CRM-361	DURAN, ELIJAH RAY	5/14/2026	A	500.00	0.00	0.00	500.00
26-01442-CRM-CCL2	JIMENEZ, NIELY JASMINE	5/26/2026	A	500.00	0.00	0.00	500.00
26-01445-CRM-CCL2	LOZOS, JONATHON	5/26/2026	A	500.00	0.00	0.00	500.00
26-01449-CRM-CCL2	REYES, SAMUEL XAVIER	5/26/2026	A	1,000.00	0.00	0.00	1,000.00
26-01465-CRM-CCL2	BRADFORD, RAY ELTON, III	5/26/2026	A	500.00	0.00	0.00	500.00
26-01556-CRM-CCL1	SONTI, SANKALP SAI	5/27/2026	A	500.00	0.00	0.00	500.00
26-01653-CRF-272	GIANT, MICHAEL DANIEL	5/8/2026	A	500.00	0.00	0.00	500.00
26-01716-CRM-CCL1	MAXEY, DAMIAN JAMAL	5/28/2026	A	750.00	0.00	750.00	0.00
26-01719-CRM-272	Dotson, Steven James, JR	5/21/2026	A	1,000.00	0.00	0.00	1,000.00
Criminal Totals				105,500.00	13,036.00	3,250.00	89,214.00
Grand Totals				105,500.00	13,036.00	3,250.00	89,214.00

Receipt Journal by Fund and Fee Code

TXBRAZOSPROD

Transaction Date Range: 05/01/2026 - 05/31/2026

Sorted by: By date, by receipt number

Tills: Brittany Olcott's Till, Collections Adjustment Till, Crystal Salinas' Till, Erika Rodrig

Case Manager District Clerk 85th District Court 272nd District Court 361st District Court 472nd District Court CCL 1 CCL 2

85th District Court

Criminal

Receipt Number	Party / Case #	Date	Totals	Fee Totals	30033000	Cashier / Station
					JSF	
Payment 2026-239495	JONES, DONTRELL DONAE 19-03778-CRF-85	AuditID: 4950145 5/8/2026	20.00	0.07	0.07	Charanza, Lori LC1
Payment 2026-240512	DAY, ANGELICA ROSHAN 18-02208-CRF-85	AuditID: 4957144 5/22/2026	10.00	0.05	0.05	Charanza, Lori LC1
Payment 2026-240677	Rodriguez, Rhonda Joan 17-04302-CRF-85	AuditID: 4959101 5/26/2026	20.00	0.10	0.10	Thomas, Kelly AG
Payment 2026-240699	AUSTON, QUINTON RAYMON 18-02853-CRF-85	AuditID: 4959484 5/26/2026	30.00	0.45	0.45	Thomas, Kelly AG

Receipt Journal by Fund and Fee Code

TXBRAZOSPROD

Transaction Date Range: 05/01/2026 - 05/31/2026 Sorted by: By date, by receipt number

Tills: Brittany Olcott's Till, Collections Adjustment Till, Crystal Salinas' Till, Erika Rodrig

Case Manager District Clerk 85th District Court 272nd District Court 361st District Court 472nd District Court CCL 1 CCL 2

272nd District Court

Criminal

Receipt Number	Party / Case #	Date	Totals	Fee Totals	30033000	Cashier / Station
					JSF	
Payment 2026-239228	TATES, STEVEN MAURICE 18-04393-CRF-272	AuditID: 4947766 5/4/2026	5.00	0.06	0.06	Charanza, Lori LC1
Payment 2026-239492	WILLIAMS, CHARLES E, Jr 18-04388-CRF-272	AuditID: 4950135 5/8/2026	5.00	0.04	0.04	Thomas, Kelly AG
Payment 2026-240467	WILLIAMS, CHARLES E, Jr 18-04388-CRF-272	AuditID: 4957002 5/22/2026	5.00	0.04	0.04	Thomas, Kelly AG
Payment 2026-240659	ARIAS, ANA LIZBETH 17-03659-CRM-272	AuditID: 4958974 5/26/2026	40.00	0.42	0.42	Charanza, Lori LC1

Receipt Journal by Fund and Fee Code

TXBRAZOSPROD

Transaction Date Range: 05/01/2026 - 05/31/2026 Sorted by: By date, by receipt number

Tills: Brittany Olcott's Till, Collections Adjustment Till, Crystal Salinas' Till, Erika Rodrig

Case Manager District Clerk 85th District Court 272nd District Court 361st District Court 472nd District Court CCL 1 CCL 2

361st District Court

Criminal

Receipt Number	Party / Case #	Date	Totals	Fee Totals	30033000	Cashier / Station
					JSF	
Payment 2026-239485	MURPHY, TAMARA SHEA 18-04051-CRF-361	AuditID: 4950018 5/7/2026	118.00	0.92	0.92	Thomas, Kelly AG
Payment 2026-239643	Whitt, Justin Levi 18-04915-CRF-361	AuditID: 4951038 5/11/2026	85.00	0.26	0.26	Skinner, Tanya TS1D
Payment 2026-239813	CHILDS, MARCUS DENARD 18-03090-CRM-361	AuditID: 4952233 5/12/2026	65.00	0.59	0.59	Thomas, Kelly AG
Payment 2026-240780	RICHARDSON, RICKY DALE 18-04519-CRF-361	AuditID: 4960069 5/27/2026	50.00	0.54	0.54	Thomas, Kelly AG
Payment 2026-240781	RICHARDSON, RICKY DALE 18-04519-CRF-361	AuditID: 4960074 5/27/2026	50.00	0.52	0.52	Thomas, Kelly AG
Void of Receipt 2026-240781	RICHARDSON, RICKY DALE 18-04519-CRF-361	AuditID: 4960076 5/27/2026	(50.00)	(0.52)	(0.52)	Thomas, Kelly AG

Receipt Journal by Fund and Fee Code

TXBRAZOSPROD

Transaction Date Range: 05/01/2026 - 05/31/2026 Sorted by: By date, by receipt number

Tills: Brittany Olcott's Till, Collections Adjustment Till, Crystal Salinas' Till, Erika Rodrig

Case Manager District Clerk 85th District Court 272nd District Court 361st District Court 472nd District Court CCL 1 CCL 2

CCL 1

Criminal

Receipt Number	Party / Case #	Date	Totals	Fee Totals	30033000	Cashier / Station
					JSF	
Payment 2026-240280	LOPEZ, ANTONIO 17-02831-CRM-CCL1	AuditID: 4955577 5/19/2026	602.00	2.45	2.45	Charanza, Lori LC1
Fee Code Totals			1,055.00	5.99	5.99	

	Totals	Fee Totals	30033000
			JSF
Total Receipts	1,055.00	5.99	5.99
Total Adjustments Impacting Receipts	0.00	0.00	0.00
Final Fee Code Totals	1,055.00	5.99	5.99

85th District Court

Criminal

Fund and Fee Account Summary	Totals	Fee Totals	30033000
			JSF
Fee Code Totals for All Funds	0.67	0.67	0.67
0100-30033000 A/P JURY REIMBURSEMT FEE	0.67	0.67	0.67
District Clerk Fund	0.67	0.67	0.67
0100 - General Fund	0.00	0.00	0.00

272nd District Court

Criminal

Fund and Fee Account Summary	Totals	Fee Totals	30033000
			JSF
Fee Code Totals for All Funds	0.56	0.56	0.56
0100-30033000 A/P JURY REIMBURSEMT FEE	0.56	0.56	0.56
District Clerk Fund	0.56	0.56	0.56
0100 - General Fund	0.00	0.00	0.00

Receipt Journal by Fund and Fee Code

Transaction Date Range: 05/01/2026 - 05/31/2026 Sorted by: By date, by receipt number

Tills: Brittany Olcott's Till, Collections Adjustment Till, Crystal Salinas' Till, Erika Rodrig

Case Manager District Clerk 85th District Court 272nd District Court 361st District Court 472nd District Court CCL 1 CCL 2

361st District Court

Criminal

Fund and GL Account Summary	Totals	Fee Totals	30033000
			JSF
Fee Code Totals for All Funds	2.31	2.31	2.31
0100-30033000 A/P JURY REIMBURSEMT FEE	2.31	2.31	2.31
District Clerk Fund	2.31	2.31	2.31
0100 - General Fund	0.00	0.00	0.00

CCL 1

Criminal

Fund and GL Account Summary	Totals	Fee Totals	30033000
			JSF
Fee Code Totals for All Funds	2.45	2.45	2.45
0100-30033000 A/P JURY REIMBURSEMT FEE	2.45	2.45	2.45
District Clerk Fund	2.45	2.45	2.45
0100 - General Fund	0.00	0.00	0.00

CCL 2

Criminal

Fund and GL Account Summary	Totals	Fee Totals	30033000
			JSF
Fee Code Totals for All Funds	0.00	0.00	0.00
District Clerk Fund	0.00	0.00	0.00
0100 - General Fund	0.00	0.00	0.00

Receipt Journal by Fund and Fee Code

TXBRAZOSPROD

Transaction Date Range: 05/01/2026 - 05/31/2026

Fee Code Summary
 85th District Court
 Criminal

Code Word	Description	Gross		Positive Adjustments		Negative Adjustments		Net	
		Amount	Number	Amount	Number	Amount	Number	Amount	Number
JSF	Juror Service Fee-Reimbursement	0.67	4	0.00	0	0.00	0	0.67	4
Sub-Totals		0.67	4	0.00	0	0.00	0	0.67	4

272nd District Court
 Criminal

Code Word	Description	Gross		Positive Adjustments		Negative Adjustments		Net	
		Amount	Number	Amount	Number	Amount	Number	Amount	Number
JSF	Juror Service Fee-Reimbursement	0.56	4	0.00	0	0.00	0	0.56	4
Sub-Totals		0.56	4	0.00	0	0.00	0	0.56	4

361st District Court
 Criminal

Code Word	Description	Gross		Positive Adjustments		Negative Adjustments		Net	
		Amount	Number	Amount	Number	Amount	Number	Amount	Number
JSF	Juror Service Fee-Reimbursement	2.31	5	0.00	0	0.00	0	2.31	5
Sub-Totals		2.31	5	0.00	0	0.00	0	2.31	5

CCL 1
 Criminal

Code Word	Description	Gross		Positive Adjustments		Negative Adjustments		Net	
		Amount	Number	Amount	Number	Amount	Number	Amount	Number
JSF	Juror Service Fee-Reimbursement	2.45	1	0.00	0	0.00	0	2.45	1
Sub-Totals		2.45	1	0.00	0	0.00	0	2.45	1

Code Word	Description	Gross		Positive Adjustments		Negative Adjustments		Net	
		Amount	Number	Amount	Number	Amount	Number	Amount	Number
		5.99	14	0.00	0	0.00	0	5.99	14

Texas A&M AgriLife Extension Service - Brazos County
MONTHLY SCHEDULE OF TRAVEL AND COMMISSIONERS COURT REPORT

Name: ROBERT STEPHEN BRUEGGERHOFF - County Extension Agent - Horticulture		Month: MAY 2026
County: BRAZOS		
DATE	MAJOR ACTIVITIES SINCE LAST REPORT	MILES
5.1.2026	Annual leave; Floral Fridays webinar broadcast; Horticulture Committee meeting	
5.4.2026	Annual leave	
5.5.2026	TMG - Advanced Training Herbs planning meeting; BCMG Tomato Tasting Event planning meeting; consultation with Comal County Extension Horticulture Agent (virtual); office management	
5.6.2026	Office management	
5.7.2026	BCMG Education Committee meeting; KAMU radio 'Garden Success' broadcast (KAMU Radio Station, 215 Lamar St, CS); office management	10.7
5.8.2026	Write article to newspaper The Eagle; Floral Fridays webinar; office management	
5.9.2026	BCMG garden volunteer workday (Demonstration Idea Garden, 2619 W State Hwy 21, Bryan)	14.2
5.11.2026	Site visit: Flasowski residence (7077 River Place Ct, College Station); office management	28.1
5.12.2026	Outreach presentation at First Presbyterean Church Senior program (First Presbyterian Church, 1100 Carter Creek Pkwy, Bryan); BCMG Board meeting; office management	10.5
5.13.2026	BCMG Tomato Tasting Event planning meeting; office management	
5.14.2026	Herb Society of America - Pioneer Unit meeting (Festival Hill, 248 Jaster Rd, Round Top); KAMU radio 'Garden Success' broadcast (KAMU Radio Station, 215 Lamar St, CS); office management	116
5.15.2026	Floral Fridays webinar; KBTX program promotion recording (KBTX Studio, 4141 East 29th St, Bryan); office management	7.1
5.16.2026	BCMG seminar: Learning at the Library at the Clara B. Mounce Library (Agent did not attend)	
5.18.2026	Office conference; office management	
5.19.2026	Texas A&M AgriLife Extension District 9 Total Faculty Workshop (Legends Event Center, 2533 Midtown Park Blvd, Bryan)	12.3
5.20.2026	Webinar - Pest insect update; office management	
5.21.2026	KAMU radio 'Garden Success' broadcast (KAMU Radio Station, 215 Lamar St, CS); office management	10.7
5/22/2026	Write article to newspaper The Eagle; Floral Fridays webinar; BCMG garden volunteer workday (Demonstration Idea Garden, 2619 W State Hwy 21, Bryan); office management	14.2
5.25.2026	National/County Holiday (Memorial Day observed)	
5.26.2026	Brazos County 4-H Pizza Ranch program planning meeting; BCMG members meeting; office management	
5.27.2026	TMG - Advanced Training Herbs workshop setup; office management	
5.28.2026	TMG - Advanced Training Herbs workshop; KAMU radio 'Garden Success' broadcast (pre-recorded broadcast); office management	
5.29.2026	TMG - Advanced Training Herbs workshop; Floral Fridays webinar; office management	
5.30.2026	TMG - Advanced Training Herbs workshop field trip (Chappel Hill Lavendar Farm, 2250 Dillard Rd, Brenham; Martha's Bloomers Café, 2101 Hwy 6 North Bypass, Navasota)	83.7
TOTAL		307.5

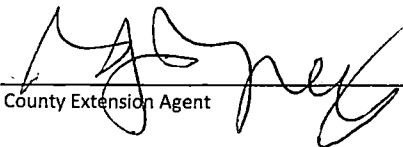
 County Extension Agent

6/5/20
 Date



Texas A&M AgriLife Extension Service
The Texas A&M University System
Extension Activity and Travel Report to County
Commissioner Court

Name: Flora Williams

Title: County Extension Agent

County: Brazos

Month: May

Date—Monthly Activities/Travel	MILES	MEALS	LODGING
5/1 Neal Head Start presentation on Healthy Eating (8 contacts)* Shopped Kroger	8.6 12.8		
5/4 Meal Prep Presentation (Brazos County Employees – Class 1; 13 contacts)*			
5/5 Brownwood Professional Association Meeting	412		
5/6 Brownwood Professional Association Meeting			
5/7 Basics of Nutrition & Physical Activity 10 10,000 Challenge Presentation (Engineering Extension; 17 contacts)* Shopped	12.8		
5/8 Cooking Well Texas Meets Mediterranean – Part 1 (Texas A&M AgriLife; 16 contacts*)			
5/11 District 9 FCH Training (Galveston)	291		
5/12 Engineering Your Wellness Fair (RELLIS Campus)*	26.9		
5/13 Bryan Head Start Nutrition Talk (9 contacts)*	11.4		
5/14 Preserving the Harvest Canning Class – Part 2 (9 contacts)*; Shopped; NEAFCS Panelist celebrating membership month	12.8		
5/15 Cooking Well Texas Meets Mediterranean – Part 2 (AgriLife Employees)* (13 contacts)			
5/16 Harris County canning class co instructor	181		
5/18 Jury Duty; Doctor’s Appointment			
5/19 Total Faculty Spring Training	12		
5/20 District 9 Total Faculty Training	17.4		
5/21 Lincoln Recreation Center Nutrition / Stroke Presentation (14 contacts)*	11.5		
5/22 Program prep; TEAFCS conference management			
5/25 Holiday			
5/26 10,000 Steps Presentation (Engineering Extension Employees – Prep & Planning); virtual TEAFCS Conference Meeting; Pizza Ranch meeting; practice interview with Lainey Dodd			
5/27 Parenting Class (1:00 PM – 5:00 PM); Doctor’s Appointment			
5/28 Advanced Herbs Training; Canning Workshop; Shopped	12.8		
5/29 Meal Prep class #2			
5/30 HTYA Super Summit	14.8		
GRAND TOTAL OF MILEAGE, MEALS & LODGING	1,037.8		

Other expenses (list) _____

CURRENT MONTH'S CONTACTS							
Extension Office Visits by Clientele	Site Visits Farm, Home, Project Ranch, Business, Etc.	Telephone	Mail	Total Individual Contacts	Total Contact Hours in Group Methods	Media News Articles, TV/Radio, Etc	Newsletters Written

DATE/ACTIVITY
6/1 – HTYA Super Summit
6/2 – Texas 4-H Roundup Fashion Show
6/3 – Texas 4-H Roundup Consumer Decision Making
6/4 – Cooking Demonstration in the Gardens (Camp Chef)
6/5 – Sick Leave
6/8 – Office Conference; <i>Cooking with Coworkers</i> Meal Prep Class 3 for County Employees
6/9 – Sick Leave
6/10 – TEAFCS Program Committee Meeting
6/11 – Program Preparation
6/12 – <i>Cooking Well: Texas Meets Mediterranean</i> Part 3 for Texas A&M AgriLife Employee Wellness
6/15 – Office Conference / Vacation
6/16 – Vacation
6/17 – 10,000 Change Challenge Presentation for Engineering Wellness; CPR Training
6/18 – <i>Preserving the Harvest</i> Class 3: Pickling Series
6/19 – County Holiday
6/22 – FPM Class; Office Conference
6/23 – Fermenting Class for Engineering Wellness at the RELLIS Campus
6/24 – Program Preparation
6/25 – Fall Prevention Class in La Grange
6/26 – Connections Workshop Onboarding Panelist; Brain Health with AgriLife Wellness part 1
6/27 – Cooking Class for Peacock Legacy of Hope; Canning Class for Private Group
6/29 – Office Conference; Office Management; Brain Health with AgriLife Wellness part 2

I hereby certify this is a true and correct report of activities, travel, and other expenses incurred by me in performance of official duties for the month shown.

Date: 6/4/2026

Signed: *Flora Williams*

Submit